



General catalogue

General catalogue

CONTENTS

2

**BEACONS &
TRAFFIC LIGHTS**

90

**GENERAL
INFORMATION**

6

**PRODUCT NUMBER
INDEX**

236

**OPTICAL-AUDIBLE
COMBINATIONS**

194

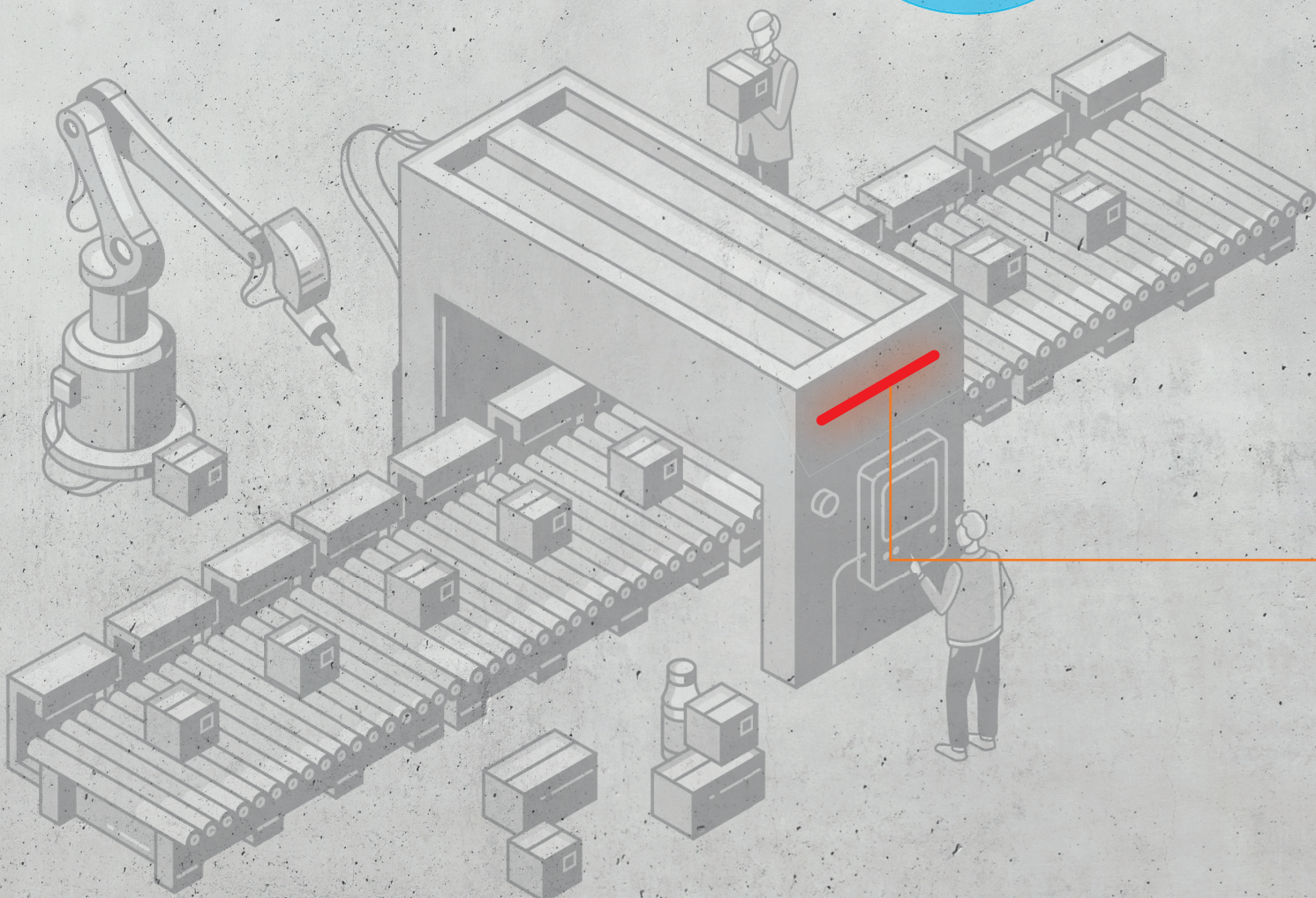

SIGNAL TOWERS

22

**HORNS & SIRENS**

152

SYSTEMS

238

**INTEGRATED
SIGNALLING**

230

The WERMA product range is completely tailored to the needs and applications of our customers from a range of industries. Compatibility, maintenance and optimisation, with a unique level of quality. This is what we call intelligent signal technology.

INTELLIGENT SIGNAL TECHNOLOGY

The products and solutions from WERMA make processes safe and keep them running efficiently. This saves you time and money and enables you to optimise your processes sustainably. Customers from various sectors all over the world have benefited from our expertise for years. Basically, because we offer clever solutions that work.

**EUROPE'S
LEADER IN
SIGNALLING**

WERMA





General Information

Key to Pictograms "Product Groups"

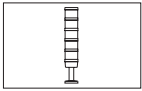

Product Group
"Signal Towers"

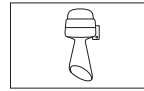

Product Group
"Horns and Sirens"

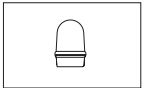

Product Group
"Beacons and Traffic lights"

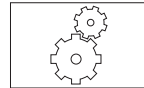

Product Group
"Systems"

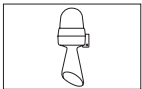

Product Group "Optical-audible combinations"

Key to Pictograms "Product Descriptions"



Protection rating according to EN 60 529. Explanation page 318



Flash energy in Watt seconds (Joules)

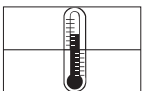

Working temperature in °C, highest and lowest rating

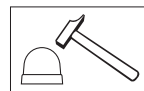

Impact resistance in Joules

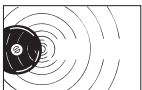

Volume in decibels (dB (A)) measured at 1m distance



Suitable for triggering via PLC



Number of possible tones

Key to Pictograms "Marks of conformity and protection types"



All WERMA products bearing the CE mark conform to current EU regulations and are tested for adherence to EMC codes.



Products in compliance with the AS-Interface specifications (EN 50295, IEC 62026-2) and which have been certified by the AS International Association are marked with the AS-Interface certification logo (shadowed logo).



Products marked with the IO-Link logo comply with the IO-Link specifications as defined in IEC 61131-9.



This mark confirms that the product is suited to the intended application and conforms to the relevant standards and guidelines. In addition, the technical specifications provided by the manufacturer are certified by the TÜV.



The Eurasian conformity symbol EAC is granted by the customs union Russia/Bellarussia/Kazakhstan. The EAC symbol confirms that the product has undergone the conformity procedures and has met its technical requirements.



Products with this mark have been tested and registered by UL for the North American market. This certification is also valid for Canada. The WERMA production facility is audited by UL.

Products with the addendum "Class 2" may only be used in electric circuits that have been constructed in accordance with UL Class 2.



German Lloyd sets technical, quality and safety standards for the industrial and maritime sector.

In addition to the classification of ships of all types, German Lloyd is also active as a world-wide technical monitoring society.



The Fraunhofer Institute certificate for production engineering and automation (IPA) is a test label for products which have been qualified according to recognised standards and guidelines as to their objective suitability for use in clean rooms.



The special organisation of the United Nations has given the ICAO (International Civil Aviation Organisation) the task of establishing and developing uniform regulations governing the safety and economic viability of civil aviation processes. The guidelines of the ICAO will only be applicable to all member states but must also be transferred into local statutes of law.



The UKCA mark (UKCA = UK Conformity Assessed) is the new UK product marking required for certain products placed on the market in the UK (England, Wales and Scotland). It affects most products that previously required the CE mark.

General Information

General notes on catalogue descriptions

Sound levels and frequencies

The specified sound levels are based on tests carried out in our factory. These levels are typical for the specific products and inevitably subject to variation. Mounting position and/or type can alter specifications.

The rated frequencies of buzzers are also dependent on the tolerances of the individual components and can vary up to 500 Hz from the quoted rating. No frequency rating can be stated for horns as the spectrum is so wide that any stated rating cannot be accurate. The fundamental frequency for AC devices is 100 Hz, for DC devices c. 200 - 500 Hz. This means that they emit a deeper tone than piezo devices which have values typically between 2000 and 3000 Hz.

Current consumption

The current consumption levels quoted are standard values. The ratings are based on the virtual value for AC, i.e. the average value for DC.

The measured value is normally calculated over a period of 10 seconds. The peak current consumption rating can be considerably higher than the calculated rating.

The start-up current of a product can be ten times greater than the rated current.

Assured values

The technical specifications of our products have been rigorously and thoroughly tested. A quality guarantee according to § 463 BGB is however only applicable where expressly stated.

WERMA is only liable for damage arising from the failure of guaranteed properties when the guarantee was expressly intended to protect the customer from this damage.

Measurements, weights, ratings and illustrations are subject to technical amendment.

Product descriptions

The product descriptions found in the price list and on all documents are made up of the following information:

Product type: Electronic Buzzer LED Permanent Beacon etc.	Fixing: BM = Base mounting BWM = Base/Wall mounting EM = Installation mounting RM = Tube mounting WM = Wall mounting	Tone type: 32 tones 4 tones etc. alternating cont./pulse continuous pulse	Voltage: 12 V 24 V 115 V 230 V etc.	Colour: BK = black BU = blue CL = clear GN = green GY = grey RD = red YE = yellow WH = white MC = multicolour
---	--	---	---	---

Examples: Electr. Buzzer EM Continuous tone 115 V AC
 LED Permanent Beacon EM 24 V DC RD

Note: Colour order of a signal tower from the bottom to the top

MTTF values

"MTTF" is the abbreviation for **Mean Time To Failure** and is also described as the average life cycle or "**MTTF_d**" (= the average time until failure leading to a dangerous situation).

The European Norm **EN ISO 13849-1** has caused a new significance to be attached to "MTTF" values, because they are used to evaluate machine safety within the

conformity tests.

The MTTF is a statistical value, which is calculated by **means of testing or experience** of past values. It does not provide a guaranteed life duration or a guaranteed functional period.

MTTF values have been calculated for a variety of **WERMA products**. Please contact us for further details.

Protection ratings

Protection ratings for signal devices: Protection ratings for housings DIN EN 60529 (DIN VDE 0470 IEC 60529).



First digit: degree of protection against contact with dangerous parts and the intrusion of foreign particles.		Second digit: degree of protection against water..	
IP 0X	no protection	IP X0	no protection
IP 1X	protection against contact with the back of the hand	IP X1	protection against vertically falling water drops
IP 2X	protection against finger contact with live or moving parts in the appliance. The test finger with \varnothing 12 mm and 80 mm length must not come into contact with dangerous parts. A ball of 12.5 mm diameter should not be able to fully penetrate the housing	IP X2	protection against water drops so long as the device is tilted to an angle of 15°
IP 3X	test bar \varnothing 2.5 mm may not penetrate the housing	IP X3	protection against water spraying at any angle up to 60° to the vertical
IP 4X	a wire with \varnothing 1 mm may not penetrate the housing	IP X4	protection against water spraying at any angle
IP 5X	complete protection against dust cannot be guaranteed, but dust is not able to accumulate in such a way as to impair the operation of the device	IP X5	protection against jets of water directed from any angle at the appliance
IP 6X	total protection against dust (no penetration)	IP X6	protection against heavy seas. A strong jet of water may not harm the appliance
		IP X7	protection against occasional immersion
		IP X8	protection against permanent immersion
		IP X9k	protection against water during high pressure / steam cleaning

Comparison between NEMA and IEC protection ratings - classification

NEMA Protection Typo Number	Protection	IEC Protection Classification Designation
1	Falling dirt	IP 10
2	Dripping water and falling dirt	IP 11
3	Wind blown dust, rain and hail; no damage due to external ice formation	IP 54
3 R	Rain and hail; no damage due to external ice formation	IP 14
3 S	Wind blown dust, rain and hail; can be operated even with external ice formation	IP 54
4	Wind blown dust, rain, splashes and a direct jet of water; no damage due to external ice formation	IP 56
4 X	Wind blown dust, rain, splashes and a direct jet of water; no damage due to external ice formation, corrosion protection	
5	Dust, falling dirt, dripping non-corrosive liquids	IP 52
6	Direct jet of water, temporary submersion; no damage due to external ice formation	IP 67
6 P	Direct jet of water, longer periods of submersion; no damage due to external ice formation	
12 und 12 K	Circulating dust, falling dirt, dripping non-corrosive liquids	IP 52
13	Dust, splashes of water, oil, non-corrosive liquids	IP 54

Cannot be used to convert IEC Classification Designations to NEMA Type Numbers.

Note: This comparison is based on tests specified in IEC Publication 60529.

	USB	IO-Link	AS-Interface
Technology	Electrically powered: Point-to-point, communication: Bus	Serial point-to-point communication	Fieldbus
Device architecture	Multi-layer star topology	Point-to-point, No bus-based architecture	Bus, star, ring and tree topologies possible
Standards	-	IEC 61131-9	EN 50295, IEC 62026-2
Maximum cable length	3m resp. 5m	20m	100m
Features	Mainly for PC-based applications	Sturdy point-to-point communication without shielded cable	Data transmission and power supply on a common unshielded cable
Products	KombiSIGN 72 KombiSIGN 71 LED Installation Beacon (Multicolour) 816 	eSIGN KombiSIGN 40 KombiSIGN 71 KombiSIGN 72 	KombiSIGN 71 KombiSIGN 72 LED Installation Beacon (Multicolour) 816 
Application examples	<ul style="list-style-type: none"> • Self-checkouts • PC-controlled testing machines • Monitoring of PC-controlled processes in production shops (e.g. printing orders) 	<ul style="list-style-type: none"> • Communication with sensor systems (e.g. Access control, filling levels or order/project status) • Integration of a signal tower into a production environment consisting of different bus systems 	<ul style="list-style-type: none"> • Integration into an existing AS-i environment

USB

USB (Universal Serial Bus) is a serial bus system for signal transmission between a computer and external devices. The devices in operation are recognised and displayed by the PC. The relevant device can be used immediately after installing the driver file provided by WERMA. WERMA USB products are compatible with various Windows versions, which are listed in the product manual. Depending on the product, the devices are controlled via VCP (virtual COM port), DLL (dynamic-link library) or exe. file.

IO-Link

IO-Link is the first standardised interface in control technology that transmits all sensor and actuator device signals to a higher-level controller. IO-Link is often referred to as the "USB interface for industry". This communications network is used to transfer data on switching states, configurations, processes and diagnoses. The special feature of IO-Link is that this technology is used to transmit control data to the lowest field level.

The IODD (IO Device Description) contains information about the device's identity, parameters, process and diagnostic data. The integration and operation of IO-Link devices can start immediately once the IODD has been imported into the user's engineering tool.

AS-Interface

AS-i (actuator/sensor interface) with its characteristic yellow cable is a modern automation bus system. A "master" organises the communications in the network automatically and exchanges process and diagnostic data with the higher-level control system. The "master" recognises the connected devices and monitors its network automatically. AS-Interface requires no specific software for this purpose. The characteristic transmission medium is an unshielded two-wire yellow cable that is responsible for transmitting both data and power. An IDC connector clamps to the cable to provide mechanical and electrical connections.

The generation of light - a summary of the possibilities

Light can be generated in various ways. In the field of signalling technology LEDs are used in the majority of applications.

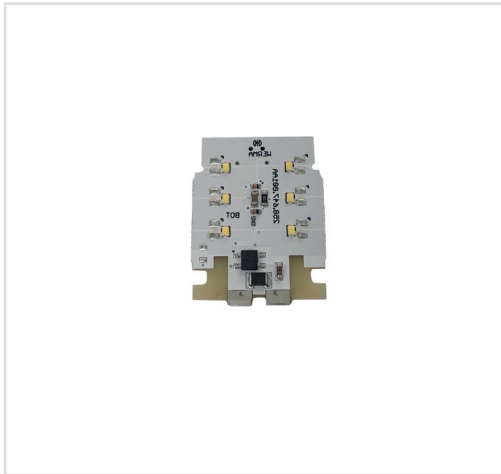

LED

Light emitting diodes are constructed using certain semiconductors. Foreign atoms are built into the semiconductor with the purpose of optimising the conductivity. Half of the semiconductor (n-region) is doped with foreign atoms that contain one bonding electron more than the semiconductor atom. This surplus atom can move freely and increases conductivity.

The other half (p-region) is doped with foreign atoms containing one electron less than the semiconductor. When the LED is switched on, these faults ("holes") fill up with free electrons (recombination). Energy in the form of radiant photons is hereby released. The energy and therefore the colour of the light emitted is determined by the material the semiconductor is made of; e.g. GaAsP (Gallium Arsenic Phosphide) results in red light.



Electric discharge tubes

Xenon flash tubes are widely used in signalling technology. They consist of a glass tube filled with the inert gas xenon. A sufficiently high voltage leads to a discharge of energy with a spark gap and a flash of high intensity.



Bulbs / Halogen bulbs

A tungsten filament is heated up to a high temperature, so radiating energy over a wide wavelength. This is perceived as light similar to sunlight. The tungsten filament evaporates with time. When the tungsten content falls below a certain level, the maximum life duration of the bulb is reached. As tungsten oxidises quickly and is destroyed when it comes into contact with air, the filament must be kept in a non-oxidising atmosphere such as vacuum. This leads us to the familiar light bulb with its sealed glass body.

These are bulbs wherein the tungsten filament is enclosed by a small amount of halogen.

The resulting chemical reaction has the effect of lengthening the life of the tungsten and stabilising the light output throughout the entire life duration of the bulb.

Light in Signalling technology

Fundamental units of light magnitude

The fields of lighting and signalling technology differentiate between fundamental units to define light itself. The most important of these are the units Lumen, Candela and Lux.

Lumen (unit lm)

Light current is measured in Lumen; this is the unit for the entire visible light output of a light-emitting source.

The light current is defined by the following formula known as the brightness characteristic:

Light current ϕ [in lm] = radiation capacity x brightness characteristic $V(\lambda)$

The brightness impression upon the human eye is based on a sensitivity curve $V(\lambda)$ which reproduces the sensation felt by the eye in relation to the wavelength. The maximum point on this curve is at about 555 nm; we see best at this wavelength; $V(555 \text{ nm}) = 1$.

Candela (unit cd)

In signalling technology only the part of the light current that is emitted in a certain direction is of importance. This light intensity is measured in Candela. It is defined by the light current of a lamp and the steradian measure.

$$\text{Light intensity [in cd]} = \frac{\text{Light current } \phi}{\text{Steradian measure } \Omega}$$

A complete sphere has a dihedral angle of $\Omega = 4 \pi \text{ sr}$. sr stands for the steradian and is the unit for the dihedral angle.

Example: a household candle emitting a light intensity of 12,566 Lumen has a light intensity in relation to the steradian measure $\frac{12,566 \text{ lm}}{4 \pi \text{ sr}} \approx 1 \text{ cd}$.

This explains the name: candela is the Latin word for candle.

Lux (unit lx)

Illumination density is an important unit in lighting installations. It is the measure of the brightness with which an area is illuminated. Whereas light intensity (in cd) is a property of a light source, illumination density is calculated in regard to the area to be illuminated.

Where the light current emitted is constant, the following formula is applicable:

$$\text{Light density E [in lux]} = \frac{\text{Light current } \phi}{\text{Surface A}}$$

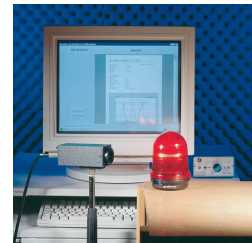
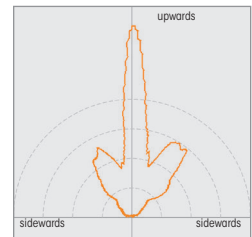

Optical Signal Devices

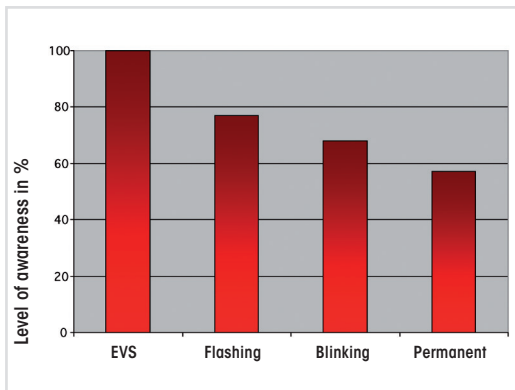

Permanent light and LED Permanent light

With the assistance of a permanent light or an LED permanent light the operator is made aware of a specific condition or is instructed to carry out a certain course of action.

For safety reasons signal beacons are increasingly equipped with light emitting diodes. The failure of optical signal devices is significantly reduced as a result of the longer life duration of LEDs. Furthermore, LEDs offer a range of advantages compared with conventional light bulbs for example lower current consumption, greater resistance to shock, vibration and other mechanical stress.



LED Beacons (Multicolour)

As well as offering traditional single coloured beacons, Werma has several multicolour LED products which give the user multiple colour choices in just one beacon.

The 816 LED beacon with USB connection uses RGB LED technology from which you can select up to 200,000 colour variants also in different light effects, such as permanent, blink or special flash.

The LED multicolour beacons 239, 240, 241 and 816 with M12 connectors offer up to 5 or 7 colours and enable you to signal several different status conditions with just one beacon.

Optical Signal Devices



(LED) Flashing or Blinking Light and LED EVS Signal Beacon

The deployment of a flashing or blinking signal can generate even more attention than a permanent light. Blinking and flashing beacons nowadays often employ long-life LED technology which has a significantly longer life duration of up to 50,000 hours with a considerably reduced power consumption.

The stochastic, random flickering light EVS (Enhanced Visibility System) has been developed by WERMA on a neurobiological basis. As deployed in LED Beacons, this technology succeeds in generating an optimal attention level never previously reached by existing signal devices.

WERMA employs LEDs for its EVS system. A microprocessor triggers random light signals, which make the light appear extremely "agitated", thus generating a continuously high attention level amongst those in the vicinity - even when viewed out the corner of the eye.



LED Rotating Signal Beacon and LED Rotating Mirror Beacon

Inside each rotating mirror beacon is an LED light source, and a mirror to deflect the light in one direction. This generates a rotating light beam.

In contrast to conventional Rotating Mirror Beacons, the LED version generates the rotating signal by means of a set of LEDs which are triggered in sequence.

As no mechanical components have been used at all, the beacon is completely maintenance-free.



Xenon Flashing Light

The deployment of a flashing signal can generate even more attention than a permanent light. The reason for this is to be found in the very short flash duration.

Inside each Xenon flashing beacon there is a capacitor which stores electrical energy. Within the space of a few milliseconds this energy is discharged within the flash tube, generating a very intense light impulse.

The life duration of a flash tube is heavily dependent on the respective load. The average life duration in permanent operation is 4×10^6 flashes.



LED Element „ultrabright“

Excellent visibility, even in direct sunlight, is a basic precondition for the reliable deployment of signal devices in outdoor areas. This is a standard feature of the signal towers and beacons from WERMA Signaltechnik. There are however applications which place even more extreme demands on the visibility of optical signalling.

Thanks to its sophisticated triggering, the innovative LED element „ultrabright“ is up to 20 times brighter than conventional LED beacons - making it almost certainly the brightest permanent light that the world of signalling technology currently has to offer.

Furthermore, the intelligent electronics ensure that the LEDs operate at maximum brightness, depending on the ambient and operating temperatures. The „ultrabright“ LED element is therefore always working at its optimum, and the energy-saving LED technology ensures that power consumption is kept to a minimum.



TwinLIGHT / TwinFLASH

TwinLIGHT and TwinFLASH combine two easily selectable light effects in one element

TwinLIGHT: Permanent and Blinking Light

TwinFLASH: Flash and EVS

OmniVIEW

Clearly visible from all positions thanks to the OmniVIEW lens with no blind spots

EVS - Enhanced Visibility System



A groundbreaking innovation in LED technology opens up a completely new dimension in optical signalling. Enhanced Visibility System, or the electronic improvement of visibility, EVS for short, is the name WERMA has given to this latest development which promises to bring about a revolution in signal technology.

This technology is generally used when a particularly high level of awareness should be generated.

Irregular light impulses can circumvent the brain's filter function. Random light signals fail to generate an acclimatisation effect and the brain is unable to escape the stimulus, even when the flickering continues for an extended period.

EVS signal devices communicate highly urgent situations



As a result of the extremely powerful signal effect, the EVS light is especially suited to signalling acute or highly important conditions. The EVS element can also be deployed in hazardous situations or in areas where immediate action is required.

Integrated into KombiSIGNAL Signal Towers, the EVS LED Element generates a highly attention-grabbing signal.

This innovative technology is also used in EvoSIGNAL and the 853, the optical-audible combinations 444 and 43x.



EVS - unique light effect using LED technology



For the EVS system WERMA employs light emitting diodes. A microprocessor generates random light signals.

This gives the light a very "agitated" character which proves highly effective in drawing the attention of those in its vicinity - even when seen out of the corner of the eye.

Up to now LED signal devices have confined themselves to imitating the light effects of light bulbs or xenon flashes, EVS however utilises the strengths of light emitting diodes. LEDs are capable of generating the required high flickering frequency with ease - frequencies which xenon flashes are for example incapable of generating.

Further advantages of LEDs are the resistance to vibration, their long life duration as well as their low current consumption.

The new EVS LED Element generates a high attention-grabbing signal effect.

Typical 2 second section of an EVS LED element's illumination sequence

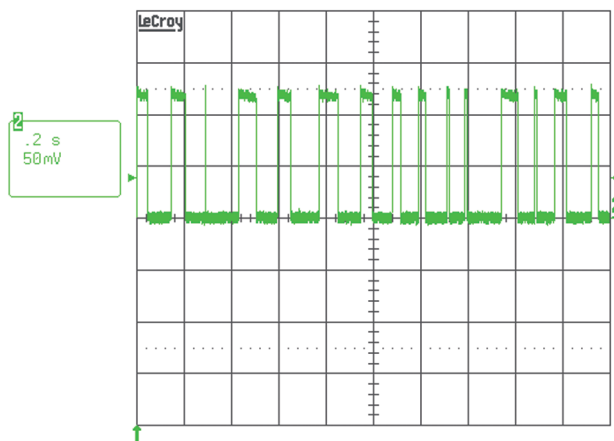

Acoustics in Signalling technology

Loudspeakers (electro-dynamic sound generation)

A loudspeaker converts an alternating electric current into sound waves. This occurs by means of the interaction between the electric current and a permanent magnet. The coil is positioned within the magnetic field of the permanent magnet. When an electric current is applied to the coil, the Lorentz force generated leads to a deflection of the coil, causing the membrane to vibrate.

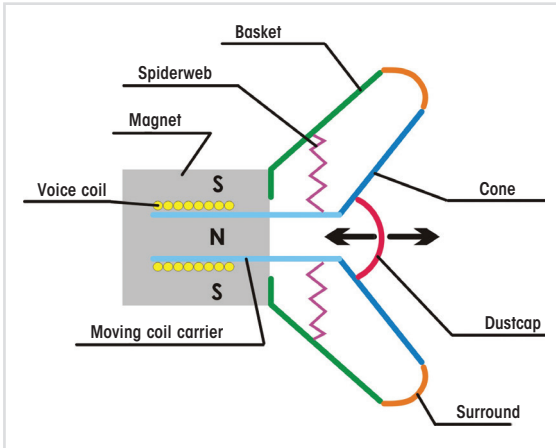

As a result of the centering spider this proceeds in an up and down motion. It centres the coil and, together with the bead, ensures that it returns to the resting position.

With the use of the appropriate size of membrane and material, as well as different drives (coils and permanent magnets), loudspeakers can be optimised for a variety of different frequency ranges.

Acoustic capsule (electromagnetic sound generation)

The acoustic capsule belongs to the group of electromagnetic sound generators. This principle was previously used for telephone earpieces. Within the capsule a permanent magnet serves to pre-magnetise the armature which is connected to the membrane. This is made to oscillate and these oscillations are then converted into audible tones. The acoustic capsule is characterized by a relatively simple construction and a compact form and displays a high degree of effectivity.



Piezo disc

Piezoelectricity (also known as the piezoelectric effect, or for short: piezo effect) refers to the interaction of mechanical pressure (Greek piezein = to press) and electrical currents in solid bodies. It describes the phenomenon whereby the deformation of certain materials leads to the generation of an electric charge at the surface (direct piezoelectric effect).

In a reverse process these materials (predominately crystals) deform when a voltage is applied. The deflection is relatively small so they need to be transmitted to a membrane, from where the oscillations excite air molecules which are then perceived as sound.

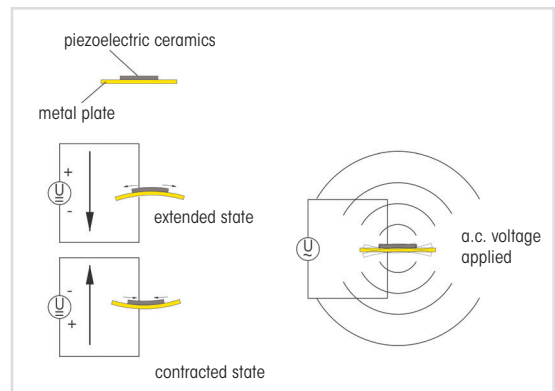

Principal acoustic parameters

Sound output level

The sound output level L_p refers to the logarithmic relationship of the square of the sound output of an acoustic event to the square of the reference value $p_0 = 20 \mu\text{P}$. The result is given in decibels (abbreviation dB).

$$L_p = 10 \log_{10} \left(\frac{p_i^2}{p_0^2} \right) \text{ dB} = 20 \log_{10} \left(\frac{p_i}{p_0} \right) \text{ dB}$$

When indicating an absolute level (with reference to the standardized reference level p_0) the abbreviation "SPL" (sound pressure level) is added.

With intermediate to high levels and frequencies a sound output difference of 10 dB is heard as approximately twice as loud. Differences of 3 dB are clearly audible. The perceived sound level is not just dependent on the sound output level, but also on the spectrum of the sound signal and its temporal progression. Single tones are perceived as being considerably louder than a broadband audible signal with the same sound output level. Audible signals with sharply changing levels are also perceived as being significantly louder than uniform audible signals with the same average level.

Weighting curves (A, B and C according to DIN EN 61672-1, formerly IEC/DIN 651) are the curves from weighting filters that are applied to the sound output signal. They are designed to reproduce a similar frequency response as that of the human ear for a specific sound level. However they are only able to achieve a rough approximation, the values obtained for the weighted sound output measurements do not exactly match those of the human ear.

Weighting levels are indicated by the corresponding letter of the frequency weighting, e.g. a C weighting sound output level is given in dB (C). In the field of technical acoustics the A weighting level is predominately employed. For this reason WERMA specifies levels in dB (A).

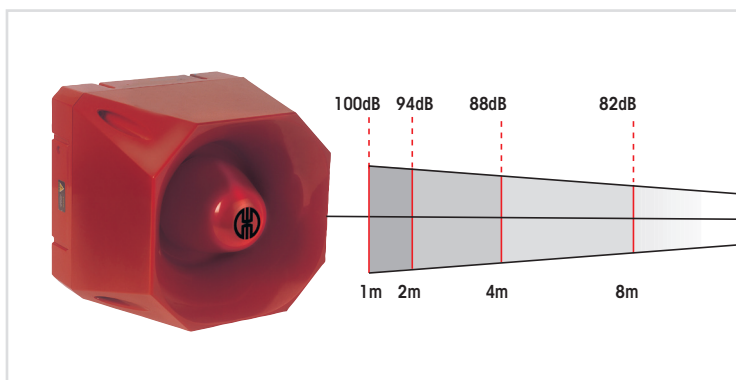

The sound output level is always dependent on the distance from the source of the sound. WERMA specifications are always based on a measuring distance of 1 m, unless otherwise stated.

In the case of point sound sources (generally applies for all sources radiating equally in all directions), the sound output level decreases by 6 dB with each doubling of the distance from the source.

Acoustics in Signalling technology

Environmental factors

In addition to the sound output level, the tone frequency and the distance to the signal device, environmental factors are also decisive for the quality of the signal. Wind, humidity or even rain all have an effect on audibility. A very important factor is the ambient noise level.

In industrial environments in particular, the ambient noise level produced by machines is often very high. Accordingly, the signal devices must produce a sufficiently high sound output in order to be heard.

WERMA has developed loud signal horns and sirens for this purpose. With fluctuating ambient noise levels, the use of a siren with a self-adjusting sound level is recommended - a patented invention from WERMA.

Table of working range

		Distance in m											
		1	2	3	5	10	20	30	50	100	200	300	500
Sound pressure level dB (A)	120	114	110	106	100	94	90	86	80	74	70	66	60
	118	112	108	104	98	92	88	84	78	72	68	64	58
	116	110	106	102	96	90	86	82	76	70	66	62	56
	114	108	104	100	94	88	84	80	74	68	64	60	54
	112	106	102	98	92	86	82	78	72	66	62	58	52
	110	104	100	96	90	84	80	76	70	64	60	56	50
	108	102	98	94	88	82	78	74	68	62	58	54	48
	106	100	96	92	86	80	76	72	66	60	56	52	46
	104	98	94	90	84	78	74	70	64	58	54	50	44
	102	96	92	88	82	76	72	68	62	56	52	48	42
	100	94	90	86	80	74	70	66	60	54	50	46	40
	98	92	88	84	78	72	68	64	58	52	48	44	38
	96	90	86	82	76	70	66	62	56	50	46	42	
	94	88	84	80	74	68	64	60	54	48	44	40	
	92	86	82	78	72	66	62	58	52	46	42	38	
	90	84	80	76	70	64	60	56	50	44	40		
	85	79	75	71	65	59	55	51	45	39			
80	74	70	66	60	54	50	46	40					
75	69	65	61	55	49	45	41						
70	64	60	56	50	44	40	36						
65	59	55	51	45	39	35							

The audibility of an audible signal is dependent on a number of different factors:

- ✔ the sound output of the signal (in dB)
- ✔ the tone frequency (in Hz)
- ✔ the distance between signal device and recipient
- ✔ the noise level of the surrounding area
- ✔ other influences (for example air humidity, wind direction)

Tone frequency

Sound is a series of fluctuations in the air pressure at different amplitudes occurring at a specific rate per unit of time. This rate is termed frequency and is measured in the unit $1/s = 1\text{ Hz}$ (Hertz). It is named after the German physicist Heinrich Rudolf Hertz. A tone is generated by an oscillation at a certain frequency. The musical tone A for example, has a frequency of 440 Hz. Noise is the term used to describe a number of overlapping tones.

The human ear is only capable of hearing tones within a certain frequency range. In the case of children this range is between 20 and 20,000 Hz. This sensitivity declines

with increasing age: by the age of 50 the limit is approximately 12,000 Hz, and with advanced age this is often as low as 5,000 Hz.

The human ear hears tones of different frequencies at different relative strengths. The limit of audibility and the pain threshold are therefore dependent on the respective frequency. For this reason audible signal devices generally operate at a frequency between 500 and 3,000 Hz.

Examples of noise in everyday life

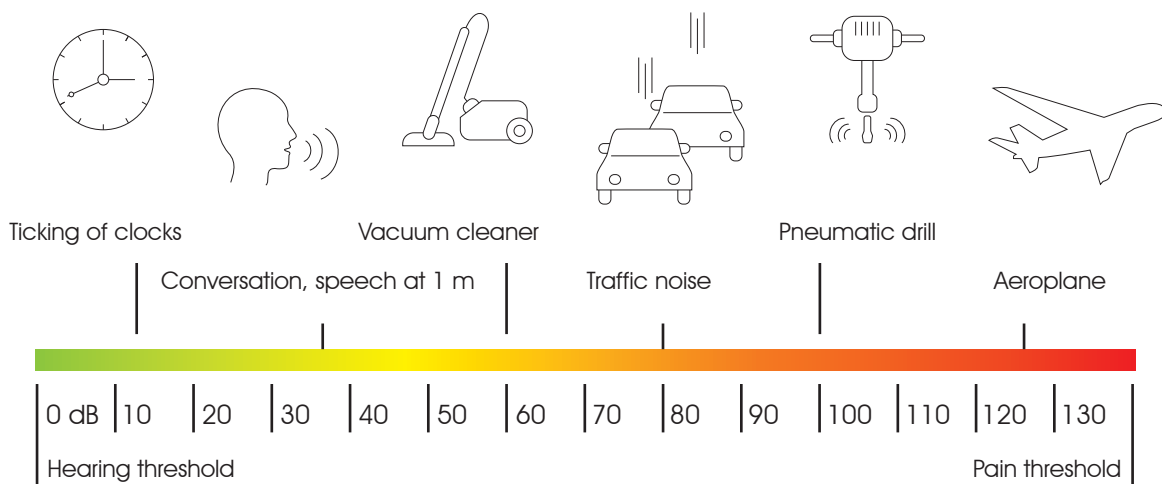



Signal Towers



Signal Towers



Signal Towers



Overview Signal Towers

Whether they are used on machinery and equipment, manual workstations or for access control and point-of-sale systems, WERMA signal towers reliably signal different statuses, such as faults or material replenishment requests. Professional signalling provides your application with greater safety and security and considerably reduces response times. The urgency of the signal can be easily increased using different signal effects. This enables employees to immediately react to faults and quickly resolve any problems that arise.

Monitor your processes, make them reliable and keep them running - saving time and money. We call this intelligent signalling technology.

Overview Signal Towers					
Product type		modular	modular	modular	pre-assembled
Technical details	Product range	KombiSIGN 40	KombiSIGN 72	KombiSIGN 71	KOMPAKT 37
Diameter*		40 mm	70 mm	70 mm	37.5 mm
Dimensions*					
Voltage	12 V			●	●
	24 V	●	●	●	●
	115 V			●	
	230 V			●	
Protection rating		IP 66/69k	IP 65	IP 65	IP 65
Number of tiers possible		1-5	1-5	1-5	1-5
Interface		I/O-Link	ASi, USB, I/O-Link, SmartMONITOR, WeASSIST	ASi, USB, I/O-Link, SmartMONITOR, WeASSIST	
Page		Page 26	Page 32	Page 38	Page 58

* Technical diagrams can be found on the product page



Modular Signal Towers

Optical and audible signal elements can be combined flexibly in the modular signal towers. The modular design also enables customers to add other elements separately when required. The mechanical and electrical connection of the signal tower elements takes mere seconds thanks to the bayonet fitting.

Completely pre-assembled Signal Towers

Completely pre-assembled WERMA Signal Towers can be ordered as a compact unit under a single part number, which reduces ordering and installation effort. Impressive features include their stylish design and diverse installation options, allowing them to be used in a wide range of areas.

pre-assembled	pre-assembled	pre-assembled	pre-assembled	pre-assembled	pre-assembled
eSIGN	RST 56	deSIGN 42	CleanSIGN	FlatSIGN	VarioSIGN
72,5 mm	57 mm	42 mm	70 mm	-	-
			112 mm x 125 mm	195 mm x 105 mm	62 mm x 90 mm
●	●	●	●	●	●
				●	
				●	
IP 66/69k	IP 66/69k	IP 65	IP 67/IP 69k	IP 65	IP 65
6, 9, 15	2-5	2-3	3	3	3
I/O-Link					
Page 62	Page 68	Page 70	Page 72	Page 74	Page 76



KombiSIGN 40 - Modular Signal Tower

Your benefits

There is no need to compromise with the KombiSIGN 40, because WERMA has combined quick installation, excellent visibility and the highest level of flexibility in this product. This saves time and money with regard to installation and order logistics.

- Save up to 50% on installation time thanks to self-explanatory connections and intuitive mechanics
- Maximum flexibility despite a small number of variants
- TwinLIGHT and TwinFLASH combine two easily selectable light effects in one element
- In ClassicLOOK or DesignLOOK to suit all machine surfaces
- Clearly visible from all positions thanks to the OmniVIEW lens with no blind spots
- Pre-configured standard versions are available (common configurations as a complete tower with a single part number)

Typical applications

Fault signalling

- on machinery and equipment
- on automated systems
- in assembly plants, for example, in the automotive industry

Installation options

- Base mounting
- Tube mounting
- Single-hole mounting
- Additional Installation options using accessories

Features

- Multicolour element offers up to seven colours in a single element
- High IP66/69k protection rating prevents ingress of dust and water
- Compact and high-output 95 dB siren
- Optionally available with IO-Link technology
- IP69k allows high pressure washing

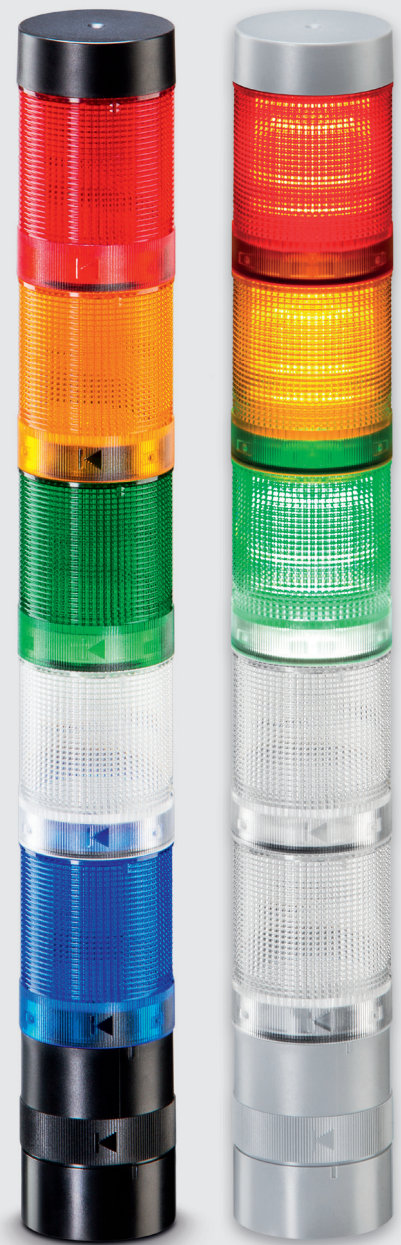

TwinLIGHT

TwinFLASH

 IO-Link

Size comparison KombiSIGN 40 / 72



How to assemble your KombiSIGN 40 signal tower

► STEP 1
Select the required optical or audible elements.
Order numbers can be found on page 29.

ClassicLOOK



Audible Signal Element

- 8 tone siren
- 2 tone siren
- 4 tone siren

Optical Signal Elements

- TwinLIGHT
- TwinFLASH
- LED Permanent light element multicolour

DesignLOOK

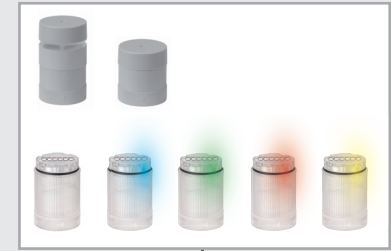

► STEP 2
Select the terminal element and appropriate mounting solution for your application.

Terminal element
Order no. **630 800 75**

IO Link terminal element
Order no. **631 800 55**

Terminal element
Order no. **630 700 75**

IO Link terminal element
Order no. **631 400 55**

► STEP 3
Optional:
Where appropriate, select the Extension tube.
Can be installed between the terminal element and the mounting adapter.

Extension tube (optional)
Order no. **960 630 03**

Extension tube (optional)
Order no. **960 630 07**

► STEP 4
Select mounting adapter as required.

Tube Mounting	Single Hole Mounting	Base Mounting
 Adapter for tube mounting Order no. 630 830 00	 Adapter for single hole mounting + cable gland M16 x 1,5 Order no. 630 820 00 + 960 630 04	 Adapter for base mounting Order no. 630 810 00

Tube Mounting	Single Hole Mounting	Base Mounting
 Adapter for tube mounting Order no. 630 730 00	 Adapter for single hole mounting + cable gland M16 x 1,5 Order no. 630 720 00 + 960 630 04	 Adapter for base mounting Order no. 630 710 00

► STEP 5
Where appropriate, select the bracket.

 Bracket for assembly on aluminium profiles with cable gland Order no. 960 630 02	 Bracket for concealed cable entry Order no. 960 630 01
--	--

 Bracket for assembly on aluminium profiles with cable gland Order no. 960 630 06	 Bracket for concealed cable entry Order no. 960 630 05
--	--

Further accessories can be found in our main catalogue page 74 or at www.werma.com.





KombiSIGN 40 - Modular Signal Tower

Or use one of our pre-configured signal towers. With just one part number you can obtain the most popular configurations.



KombiSIGN 40 Signal Tower
in ClassicLOOK und DesignLOOK

TECHNICAL SPECIFICATIONS/ORDER SPECIFICATIONS:

Pre-configured signal tower	ClassicLOOK	DesignLOOK
Dimensions (Ø x Height)	40 mm x 214 mm	
Voltage	24 V AC/DC	
TwinLIGHT green/yellow/red	639 300 01	639 301 01
Consisting of		
	 634 110 75 + 634 310 75 + 634 210 75 + 630 800 75 + 630 810 00	 634 130 75 + 634 330 75 + 634 230 75 + 630 700 75 + 630 710 00

Technical details are given on the relevant product page.

✂ ACCESSORIES

	ClassicLOOK	DesignLOOK
Bracket for concealed cable entry	960 630 01	960 630 05

↔ TECHNICAL DIAGRAMS:

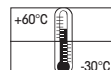
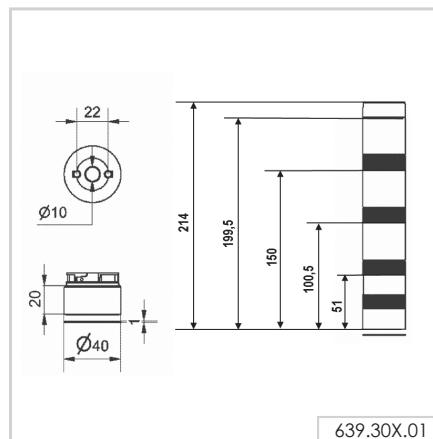

KombiSIGN 40 - Optical Signal Elements



KombiSIGN 40 Signal Tower
in ClassicLOOK and DesignLOOK

① TECHNICAL SPECIFICATIONS/ORDER SPECIFICATIONS:

	ClassicLOOK	DesignLOOK
Dimensions (Ø x Height)	40 mm x 59 mm	
Lens	PC, transparent	
Life duration	50,000 hrs	
TwinLIGHT		
Light effects	LED Permanent or Blinking light, adjustable via slide switch	
Voltage	24 V AC/DC	
Current consumption	< 30 mA	
red	634 110 75	634 130 75
green	634 210 75	634 230 75
yellow	634 310 75	634 330 75
white	634 430 75	634 430 75
blue	634 510 75	634 530 75
TwinFLASH		
Light effect	LED Flash light or EVS, adjustable via DIP-Switch	
Voltage	24 V DC	
Current consumption	< 65 mA	
red	634 120 55	634 140 55
green	634 220 55	634 240 55
yellow	634 320 55	634 340 55
white	634 440 55	634 440 55
blue	634 520 55	634 540 55
Multicolour		
Light effect	LED Permanent light	
Colours	Red, yellow, green, blue, white, violet, turquoise controlled by binary inputs	
Voltage	24 V DC	
Current consumption	< 60 mA	
Order No.	634 450 55	634 450 55

↔ TECHNICAL DIAGRAMS:

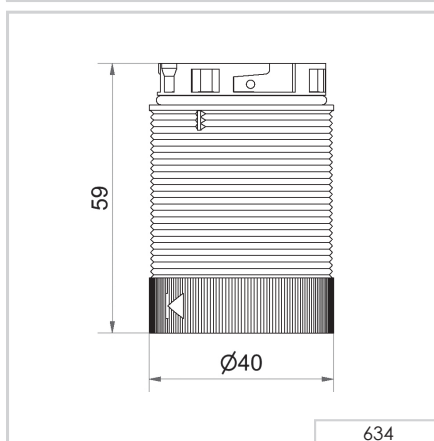

KombiSIGN 40 - Audible Signal Elements



4 or 8 tone
KombiSIGN 40 siren
in DesignLOOK



2 tone KombiSIGN 40 siren
in ClassicLOOK

① TECHNICAL SPECIFICATIONS/ORDER SPECIFICATIONS:

	ClassicLOOK	DesignLOOK
Housing	PC	
Life duration	5,000 hrs	
2 Tone Siren		
Dimensions (Ø x Height)	40 mm x 45 mm	
Sound output	85 dB (A)	
Tone type	Continuous or pulse tone, can be set via slide switch	
Voltage	24 V AC/DC	
Current consumption	< 80 mA	
Order No.	635 800 75	635 700 75
4 Tone Siren		
Dimensions (Ø x Height)	40 mm x 68 mm	
Sound output	67-95 dB (A)	
Tone type	4 tones, can be set via DIP switch	
Voltage	24 V AC/DC	
Current consumption	< 200 mA	
Order No.	635 820 75	635 720 75
8 Tone Siren		
Dimensions (Ø x Height)	40 mm x 68 mm	
Sound output	89-95 dB (A), can be set via DIP switch	
Tone type	8 tones, can be set via slide switch	
Voltage	24 V AC/DC	
Current consumption	< 200 mA	
Order No.	635 810 75	635 710 75

↔ TECHNICAL DIAGRAMS:

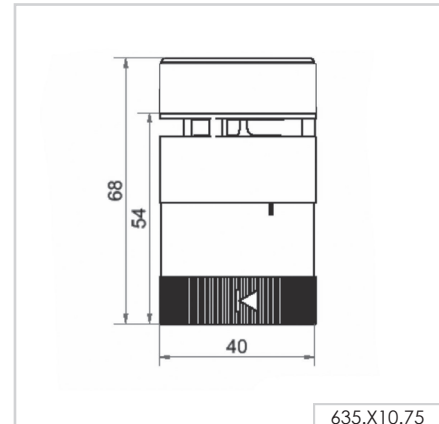
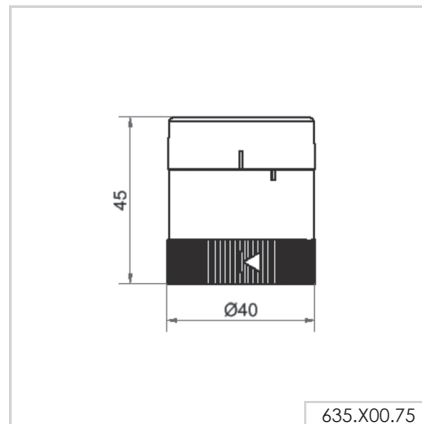

KombiSIGN 40 - Terminal Elements



KombiSIGN 40 DesignLOOK assembly adapter for single hole mounting



KombiSIGN 40 ClassicLOOK assembly adapter for base mounting



IO-Link terminal element KombiSIGN 40 ClassicLOOK



KombiSIGN 40 DesignLOOK assembly adapter for tube mounting

① TECHNICAL SPECIFICATIONS/ORDER SPECIFICATIONS:

	ClassicLOOK	DesignLOOK
Housing:	PC	
Number of tiers possible	Max. 5	
Terminal element		
Dimensions (Ø x Height)	40 mm x 40 mm	
Cable entry	Cable diameter max. 9 mm	
Connection	Push-in terminal max. 1.5 mm ²	
Voltage	24 V AC/DC	
Order No.	630 800 75	630 700 75
IO Link Terminal element		
Dimensions (Ø x Height)	40 mm x 59 mm	
Cable entry	Cable diameter max. 9 mm	
Connection	Push-in terminal max. 0.75 mm ²	
Voltage	24 V via IO-Link	
Current consumption	10 mA	
Order No.	631 800 55	631 400 55
Adapter for base mounting		
Dimensions (Ø x Height)	40 mm x 30 mm	
Order No.	630 810 00	630 710 00
Adapter single hole mounting		
Dimensions (Ø x Height)	40 mm x 54 mm	
Order No.	630 820 00	630 720 00
Adapter tube mounting		
Dimensions (Ø x Height)	40 mm x 75 mm	
Order No.	630 830 00	630 730 00

✂ ACCESSORIES: SEE PAGE 27

↔ TECHNICAL DIAGRAMS:

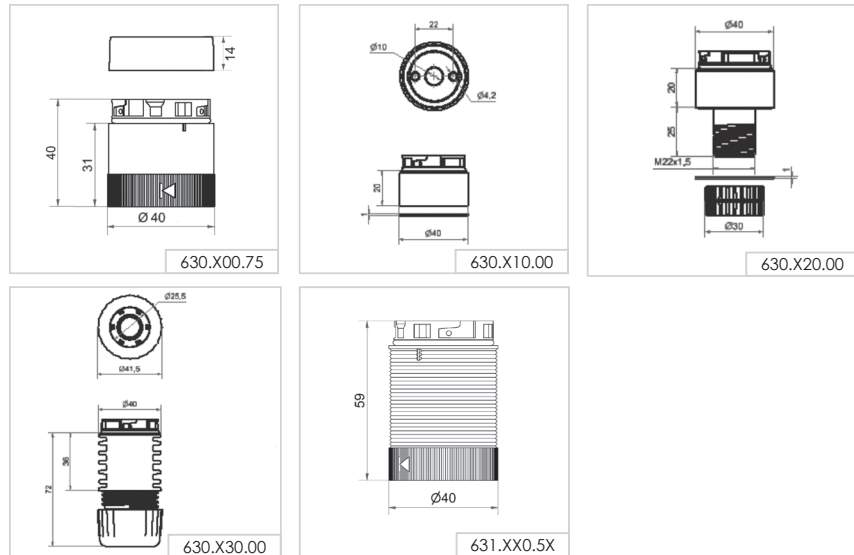



KombiSIGN 72 - Signal Tower

Your benefits

There is no need to compromise with the KombiSIGN 72, because this product combines quick installation, excellent visibility and the highest level of flexibility. This saves time and money with regard to installation and order logistics.

- Smooth surfaces prevent dirt gathering and make cleaning easy
- Easy, intuitive installation - incorrect assembly is practically impossible (Poka Yoke)
- High-tech: the Signal Towers can easily be retrofitted with SmartMONITOR (smart MDC alternative), WeASSIST, AndonSPEED (call-for-action system) or AndonWIRELESS
- TwinLIGHT and TwinFLASH combine two easily selectable light effects in one element
- In ClassicLOOK or DesignLOOK to suit all machine surfaces
- Clearly visible from all positions thanks to the OmniVIEW lens with no blind spots
- Pre-configured standard versions are available (common configurations as a complete tower with a single part number)

Typical applications

The new definition of the industry standard to signal faults

- on machinery and equipment
- on automated systems
- in assembly plants, for example, in the automotive industry
- on conveyor belts in production and logistics
- at manual workstations as a call-for-action system
- upgradeable to SmartMONITOR, WeASSIST, AndonSPEED or AndonWIRELESS

Installation options

- Base mounting
- Tube mounting
- Additional installation options using accessories

Features

- Combine the KombiSIGN 72 light elements with special controller solutions such as I/O-Link, USB or ASI, or integrate one of the versatile audible elements
- Can be combined and retrofitted with all the KombiSIGN 71 elements and accessories, as well as the SmartMONITOR, WeASSIST, AndonWIRELESS and AndonSPEED wireless-based systems
- High-output 105 dB siren

Size comparison KombiSIGN 72/40



TwinLIGHT

TwinFLASH



 **IO-Link**

How to assemble your KombiSIGN 72 signal tower

ClassicLOOK

DesignLOOK

► STEP 1
Select the required optical or audible elements in the correct voltage (for details see page 35).

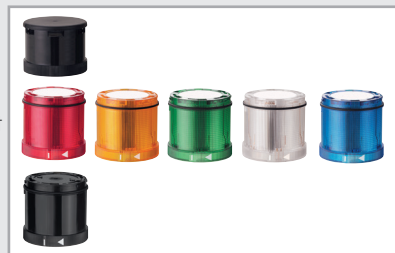

- Audible Signal Element
- 2 tone siren
 - 8 tone siren
- Optical Signal Elements
- TwinLIGHT
 - TwinFLASH
- IO Link terminal element

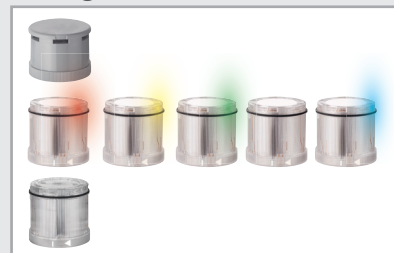

► STEP 2
Select the appropriate mounting option for your application.

► STEP 3
Select the correct terminal element for your mounting option (for details see page 37).

ClassicLOOK		DesignLOOK	
Base Mounting	Tube Mounting	Base Mounting	Tube Mounting
Terminal element with CAGE CLAMP® technology Order no. 640 800 00	Terminal element with CAGE CLAMP® technology Order no. 640 810 00	Terminal element with CAGE CLAMP® technology Order no. 640 900 00	Terminal element with CAGE CLAMP® technology Order no. 640 910 00

► STEP 4
Where appropriate, select a base and the desired tube length (only for tube mounting) (For details see page 78).

ClassicLOOK		DesignLOOK	
	<p>Tube Ø 25 mm, all anodised</p> <p>Order no.</p> <p>100 mm long 975 845 10</p> <p>250 mm long 975 840 25</p> <p>400 mm long 975 840 40</p> <p>600 mm long 975 840 60</p> <p>800 mm long 975 840 80</p> <p>1000 mm long 975 840 03</p> <p>Base for Tube, plastic Order no. 975 840 90</p> <p>Base for Tube, metal Order no. 975 840 91</p>		<p>Tube Ø 25 mm, all anodised</p> <p>Order no.</p> <p>100 mm long 975 845 10</p> <p>250 mm long 975 840 25</p> <p>400 mm long 975 840 40</p> <p>600 mm long 975 840 60</p> <p>800 mm long 975 840 80</p> <p>1000 mm long 975 840 03</p> <p>Base for Tube, plastic Order no. 960 000 50</p>

► STEP 5
Where appropriate, select the bracket and the contact box (for details see page 78).

ClassicLOOK		DesignLOOK	
	Bracket for base mounting with concealed cable entry Order no. 960 000 14		Bracket for base mounting with concealed cable entry Order no. 960 000 55
Bracket for 1-sided mounting Order no. 975 840 85	Bracket for tube mounting Order no. 960 000 01	Bracket for 1-sided mounting Order no. 960 000 52	Bracket for tube mounting Order no. 960 000 54
Bracket for 2-sided mounting Order no. 975 840 86			

Look at the signal device section on: www.werma.com

With the new signal tower configurator you can put together your own individual signal tower.

Further accessories can be found in our main catalogue page 74 or at www.werma.com.









KombiSIGN 72 - Modular Signal Tower

Or use one of our pre-configured signal towers. With just one part number you can obtain the most popular configurations.



❶ TECHNICAL SPECIFICATIONS/ORDER SPECIFICATIONS:		
Pre-configured signal tower	ClassicLOOK	DesignLOOK
Dimensions (Ø x Height)	70 mm x 211.5 mm	
Voltage	24 V AC/DC	
Base/Bracket mounting		
Consisting of:		
	 647 110 75 + 647 310 75 + 647 210 75 + 640 800 00	 647 130 75 + 647 330 75 + 647 230 75 + 640 900 00
TwinLIGHT green/yellow/red	649 000 01	649 001 01
Tube mounting		
Dimensions (Ø x Height)	70 mm x 299 mm	
Consisting of:		
	 647 110 75 + 647 310 75 + 647 210 75 + 640 810 00 + 975 840 10	 647 130 75 + 647 330 75 + 647 230 75 + 640 910 00 + 960 000 51
TwinLIGHT green/yellow/red	649 000 02	649 001 02

Technical details are given on the relevant product page.

✂ ACCESSORIES:

	ClassicLOOK	DesignLOOK
Bracket for 1-sided mounting	975 840 85	960 000 52
Bracket for base mounting	960 000 02	960 000 53
Bracket for tube mounting	960 000 01	960 000 54

↔ TECHNICAL DIAGRAMS:

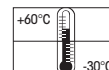
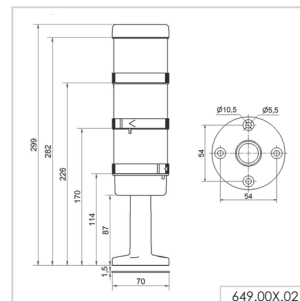
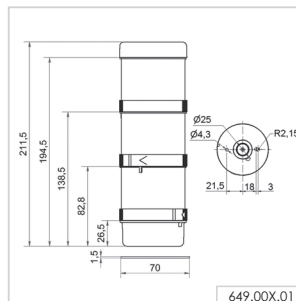

KombiSIGN 72 - Optical Signal Elements



① TECHNICAL SPECIFICATIONS/ORDER SPECIFICATIONS:

	ClassicLOOK	DesignLOOK
Dimensions (Ø x Height)	70 mm x 65,5 mm	
Lens	PC, transparent	
TwinLIGHT		
Light effects	LED Permanent light, LED Blinking light, adjustable via slide switch	
Voltage	24 V AC/DC	
Current consumption	< 80 mA	
red	647 110 75	647 130 75
green	647 210 75	647 230 75
yellow	647 310 75	647 330 75
white	647 430 75	647 430 75
blue	647 510 75	647 530 75
TwinFLASH		
Light effect	LED Flashing light, LED EVS light, adjustable via slide switch	
Voltage	24 V DC	
Current consumption	< 80 mA	
red	647 120 55	647 140 55
green	647 220 55	647 240 55
yellow	647 320 55	647 340 55
white	647 440 55	647 440 55
blue	647 520 55	647 540 55

↪ TECHNICAL DIAGRAMS:

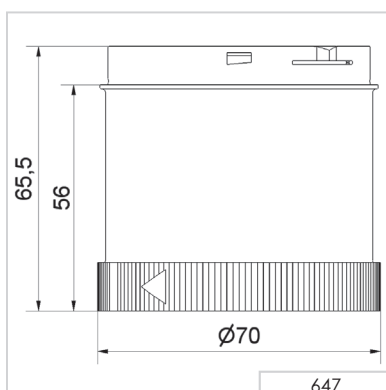

KombiSIGN 72 - Audible Signal Elements



2 and 8 tone siren
KombiSIGN 72
DesignLOOK

① TECHNICAL SPECIFICATIONS/ORDER SPECIFICATIONS:

	ClassicLOOK	DesignLOOK
Housing	PC	
Life duration	5,000 hrs	
2 Tone Siren		
Dimensions (Ø x Height)	70 mm x 54 mm	
Sound output	95-105 dB (A), adjustable by slide switch	
Tone type	Permanent tone or alternating tone, selectable by slide switch	
Voltage	24 V AC/DC	24 V AC/DC
Current consumption	< 40 mA	< 40 mA
Order no.	645 870 75	645 770 75
8 Tone Siren		
Dimensions (Ø x Height)	70 mm x 54 mm	
Sound output	95-105 dB (A), adjustable by slide switch	
Tone type	8 tones, can be set via slide switch	
Voltage	24 V AC/DC	24 V AC/DC
Current consumption	< 30 mA	< 30 mA
Order no.	645 890 75	645 790 75
Voltage	115-230 V AC	115-230 V AC
Current consumption	< 45 mA	< 45 mA
Order no.	645 890 60	645 790 60

↔ TECHNICAL DIAGRAMS:

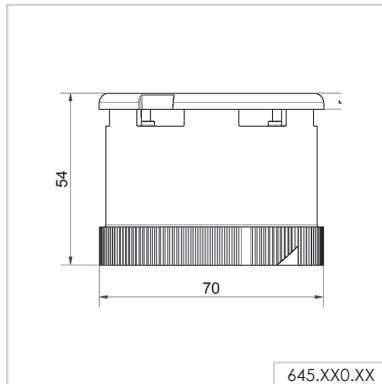

KombiSIGN 72 - Terminal Elements



Terminal element
KombiSIGN 72
DesignLOOK



Terminal element
KombiSIGN 72
ClassicLOOK



IO Link element
KombiSIGN 72
ClassicLOOK



IO Link element
KombiSIGN 72
DesignLOOK

TECHNICAL SPECIFICATIONS/ORDER SPECIFICATIONS:

	ClassicLOOK	DesignLOOK
Dimensions (Ø x Height)	70 mm x 36 mm	
Housing	Terminal element: PA-GF Cap: PC	
Fixing	Base mounting, Tube mounting for tube Ø 25 mm (accessory), Bracket mounting (accessory)	
Cable entry	Cable diameter max. 11 mm	
Connection	CAGE CLAMP® technology max. 1.5 mm ²	
Protection rating	IP 65	
Number of tiers possible	Max. 5	
Voltage	12-230 V AC/DC	
Base mounting	640 800 00	640 900 00
Tube mounting	640 810 00	640 910 00
Terminal element M12		
Dimensions (Ø x Height)	70 mm x 59 mm	
Voltage	12-24 V DC	
Current carrying capacity	≤ 2 A	
8 pole (up to 5 tiers)	640 880 00	640 980 00
5 pole (up to 4 tiers)	640 870 00	640 970 00
IO Link element		
Dimensions (Ø x Height)	70 mm x 65.5 mm	
Numbers of tiers possible	Max. 5	
Voltage	24 V via IO-Link	
Current consumption	6 mA	
Order no.	646 840 55	646 440 55

ACCESSORIES:

	ClassicLOOK	DesignLOOK
Base with integrated tube	975 840 10	960 000 51
Bracket for 1-sided mounting	975 840 85	960 000 52
Bracket for base mounting	960 000 02	960 000 53
Bracket for tube mounting	960 000 01	960 000 54
Bracket for base mounting with concealed cable entry	960 000 14	960 000 55
Base for tube Ø 25 mm, plastic	975 840 90	960 000 50

Additional accessories can be found on page 74.

TECHNICAL DIAGRAMS:

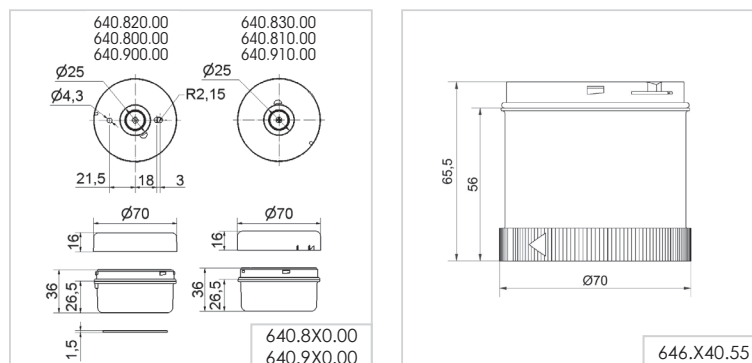

646.440.55
Class 2

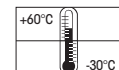



KombiSIGN 71 - Signal Tower

Your benefits

The KombiSIGN 71 has successfully established itself as the standard in industrial applications over recent years. The patented bayonet mechanism enables elements to be installed or removed in a matter of seconds.

- A wide range of accessories ensures maximum flexibility
- High-tech: The Signal Towers can easily be retrofitted with SmartMONITOR (intelligent MDC alternative), WeASSIST or AndonSPEED (call-for-action system)
- Completely pre-configured standard versions are available (common configurations as a complete tower with a single part number)

Typical applications

Signalling fault messages

- on machinery and equipment
- on automated systems
- in assembly plants, for example, in the automotive industry
- in the building services industry

Installation options

- Base mounting
- Tube mounting
- Additional installation options using accessories

Features

- Different light effects are possible for individual signalling
- The Multicolour element offers up to seven colours in a single element
- The self-adjusting siren element automatically adapts to the ambient noise level
- Vocal element for your own mp3 or wav files
- Combine the KombiSIGN 71 light elements with special controller solutions such as USB, I/O-Link or ASI, or integrate one of the versatile audible elements



Size comparison KombiSIGN 71/40



How to assemble your KombiSIGN 71 signal tower

► STEP 1

Select the required optical or audible elements in the correct voltage (for details see page 41).



Audible Signal Elements

- Buzzer element
- Siren element
- Vocal element

Optical Signal Elements







- (LED) Permanent light
- LED Permanent light ultrabright
- LED Flashing light
- LED EVS element
- LED Blinking light
- LED Rotating light
- LED Permanent light element multicolour

► STEP 2

Select the appropriate mounting option for your application.



► STEP 3

Select the correct terminal element for your mounting option (for details see page 45).

Base Mounting	Tube Mounting
 Terminal element with CAGE CLAMP® technology Order no. 640 800 00	 Terminal element with CAGE CLAMP® technology Order no. 640 810 00
 Screw terminal Order no. 640 820 00	 Screw terminal Order no. 640 830 00
 Terminal element M12 8 pole 640 880 00 5 pole 640 870 00	 Terminal element M12 8 pole 640 880 00 5 pole 640 870 00

► STEP 4

Where appropriate, select a base and the desired tube length (only for tube mounting) (For details see page 78).











 Tube with clamp Order no. 960 000 18	 Adaptor for single hole mounting Order no. 960 000 25	 Base with integrated tube Order no. 975 840 10	<p>Tube Ø 25 mm, all anodised</p> <p>100 mm long Order no. 975 845 10</p> <p>250 mm long Order no. 975 840 25</p> <p>400 mm long Order no. 975 840 40</p> <p>600 mm long Order no. 975 840 60</p> <p>800 mm long Order no. 975 840 80</p> <p>1000 mm long Order no. 975 840 03</p> <p>Base for Tube, plastic Order no. 975 840 90</p> <p>Base for Tube, metal Order no. 975 840 91</p> <p>Foldaway Base Order no. 960 000 30</p> <p>Foldaway Base Order no. 960 009 12</p> <p>Tube Ø 25 mm, plastic, only for Foldaway Base, 45 mm long Order no. 960 000 31</p> 
--	---	--	--

► STEP 5

Where appropriate, select the bracket and the contact box (for details see page 78).

Look at the signal device section on:
www.werma.com

With the signal tower configurator you can put together your own individual signal tower.





 Contact box for cable exit at side Order no. 975 840 01	 Contact box for cable exit at side Order no. 975 840 01
 Bracket for base mounting Order no. 960 000 02	 Contact box with magnetic base and cable exit at side Order no. 975 840 04
 Bracket for 1-sided mounting Order no. 975 840 85	 Bracket for base mounting with concealed cable entry Order no. 960 000 14
 Bracket for 2-sided mounting Order no. 975 840 86	 Bracket for tube mounting Order no. 960 000 01
 Corner fixing bracket Order no. 960 000 41	 Corner fixing bracket Order no. 960 000 41



KombiSIGN 71 - Signal Tower

Or use one of our pre-configured signal towers. With just one part number you can obtain the most popular configurations.



① TECHNICAL SPECIFICATIONS/ORDER SPECIFICATIONS:		
Pre-configured signal tower	2 tier	3 tier
Voltage	24 V AC/DC	24 V AC/DC
Base/Bracket mounting		
Consisting of:	 644 100 75 + 644 200 75 + 640 800 00	 644 100 75 + 644 300 75 + 644 200 75 + 640 800 00
Dimensions (Ø x Height)	70 mm x 155 mm	70 mm x 211.5 mm
LED Permanent Light green/yellow/red	-	649 240 02
LED Permanent Light green/red	649 240 04	-
Tube mounting		
Consisting of:	 644 100 75 + 644 200 75 + 640 810 00 + 975 840 10	 644 100 75 + 644 300 75 + 644 200 75 + 640 810 00 + 975 840 10
Dimensions (Ø x Height)	70 mm x 242 mm	70 mm x 299 mm
LED Permanent Light green/yellow/red	-	649 240 05
LED Permanent Light green/red	649 240 06	-

Technical details are given on the relevant product page.

✂ ACCESSORIES:

Bracket for 1-sided mounting	975 840 85
Bracket for surface mounting	960 000 02
Bracket for base mounting	960 000 01

← TECHNICAL DIAGRAMS:

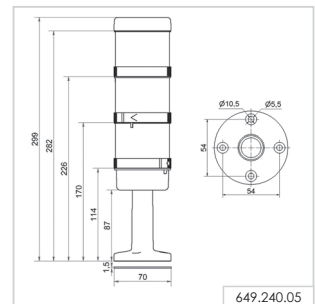
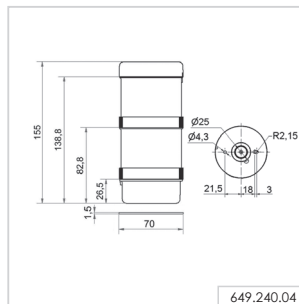
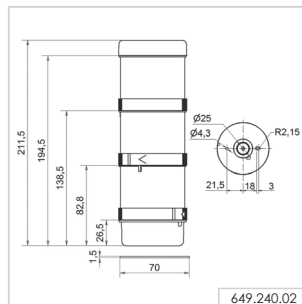
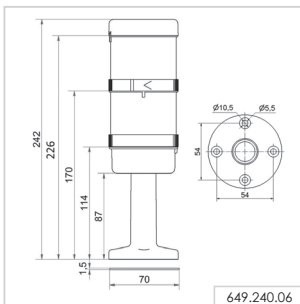

KombiSIGN 71 - Optical Signal Elements



① TECHNICAL SPECIFICATIONS/ORDER SPECIFICATIONS:

Dimensions (Ø x Height)	70 mm x 65.5 mm			
Lens	PC, transparent			
Socket	Bayonet, BA15d, for bulbs max. 5 W			
Protection rating	IP 65			
Life duration	50,000 hrs (LED)			
Permanent light element	12-240 V AC/DC			
red	641 100 00			
green	641 200 00			
yellow	641 300 00			
clear	641 400 00			
blue	641 500 00			
Life duration	Dependent upon the bulbs used			
Bulb not included in assembly.				
LED Permanent light element	24 V AC/DC	115 V AC	230 V AC	
Current consumption	< 35 mA	< 25 mA	< 35 mA	
red	644 100 75	644 100 67	644 100 68	
green	644 200 75	644 200 67	644 200 68	
yellow	644 300 75	644 300 67	644 300 68	
clear	644 400 75	644 400 67	644 400 68	
blue	644 500 75	644 500 67	644 500 68	
LED Permanent light element ultrabright	24 V DC			
Current consumption	< 195 mA			
red	644 180 55			
green	644 280 55			
yellow	644 380 55			
clear	644 480 55			
blue	644 580 55			
Flashing light element (Xenon)	24 V DC (ASI)	24 V DC	115 V AC	230 V AC
Current consumption	< 80 mA	< 125 mA	< 22 mA	< 15 mA
red	643 110 55	643 100 55	643 100 67	643 100 68
green	643 210 55	643 200 55	643 200 67	643 200 68
yellow	643 310 55	643 300 55	643 300 67	643 300 68
clear	643 410 55	643 400 55	643 400 67	643 400 68
blue	643 510 55	643 500 55	643 500 67	643 500 68
Life duration	4 x 10 ⁶ flashes			
Flash frequency	c. 1 Hz			
LED Flashing light element	24 V DC			
Current consumption	< 35 mA			
red	644 120 55			
green	644 220 55			
yellow	644 320 55			
clear	644 420 55			
blue	644 520 55			
Flash frequency	c. 1 Hz (Double Flash)			



643 X10 55
Class 2

24 V





KombiSIGN 71 - Optical Signal Elements

TECHNICAL SPECIFICATIONS/ORDER SPECIFICATIONS:

LED EVS element	24 V AC/DC		
Current consumption	350 mA		
red	644 140 55		
green	644 240 55		
yellow	644 340 55		
clear	644 440 55		
blue	644 540 55		
LED Blinking light element	24 V AC/DC	115 V AC	230 V AC
Current consumption	< 25 mA	< 25 mA	< 35 mA
red	644 110 75	644 110 67	644 110 68
green	644 210 75	644 210 67	644 210 68
yellow	644 310 75	644 310 67	644 310 68
clear	644 410 75	644 410 67	644 410 68
blue	644 510 75	644 510 67	644 510 68
Blink frequency	c. 1 Hz		
LED Rotating light element	24 V AC/DC		
Current consumption	< 40 mA		
red	644 130 75		
green	644 230 75		
yellow	644 330 75		
clear	644 430 75		
blue	644 530 75		
Rotation frequency	c. 120 r.p.m.		
LED Permanent light element multicolour	24 V DC		
Current consumption	< 120 mA		
Multicolour	644 450 55		
Possible colours	Red, yellow, green, white, blue, violet, turquoise controlled by binary inputs		
Number of modules possible	Max. 3 (including multicolour element)		

Further voltages on request.

TECHNICAL DIAGRAMS:

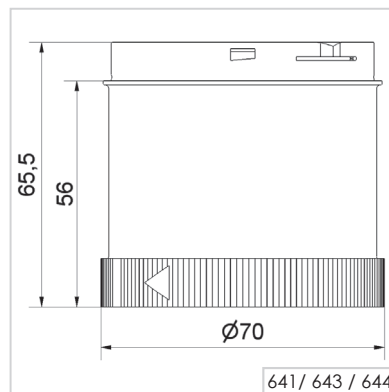

643 X10 55
Class 2

24 V

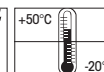

KombiSIGN 71 - Audible Elements



Buzzer element



Siren element ClassicLOOK



Siren element DesignLOOK

① TECHNICAL SPECIFICATIONS/ORDER SPECIFICATIONS:

Dimensions (Ø x Height)	See below		
Lens	PC		
Protection rating	IP 65		
Life duration	5,000 hrs		

Buzzer element

Dimensions (Ø x Height)	70 mm x 72 mm		
Sound output	85 dB (A)		
Number/Tone type	Continuous or pulse tone		
Voltage	24 V AC/DC	115 V AC	230 V AC
Current consumption	< 35 mA	< 25 mA	< 25 mA
Order no.	645 800 75	645 800 77	645 800 68

Siren element

Dimensions (Ø x Height)	70 mm x 54 mm		
Sound output	95-105 dB (A), adjustable by slide switch		
Number/Tone type	Continuous tone, alternating tone, selectable by slide switch		
Voltage	24 V AC/DC	115 V AC	230 V AC
Current consumption	< 40 mA	< 60 mA	< 60 mA
Order no.	645 870 75	645 870 67	645 870 68

Siren element 8 tones

Dimensions (Ø x Height)	70 mm x 72 mm		
Sound output	92-102 dB (A), adjustable sound output		
Number/Tone type	8 tones		

ClassicLOOK

Voltage	24 V AC/DC	115-230 V AC
Current consumption	< 30 mA	< 45 mA
Order no.	645 890 75	645 890 60

DesignLOOK

Voltage	24 V AC/DC	115-230 V AC
Current consumption	< 30 mA	< 45 mA
Order no.	645 790 75	645 790 60

Multi-functional Siren, with external control

Dimensions (Ø x Height)	70 mm x 72 mm		
Sound output	100 dB (A), adjustable sound output		
Number/Tone type	Number of tones dependent on the number of optical elements		
Tone triggering	7 diff. tones can be triggered externally		
Voltage	24 V DC		
Current consumption	< 80 mA		
Order no.	645 850 55		

↔ TECHNICAL DIAGRAMS:

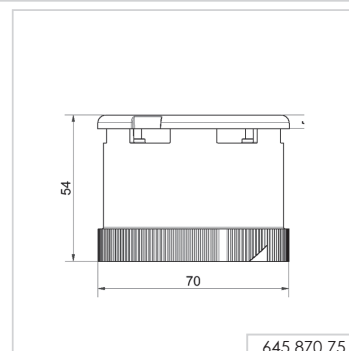
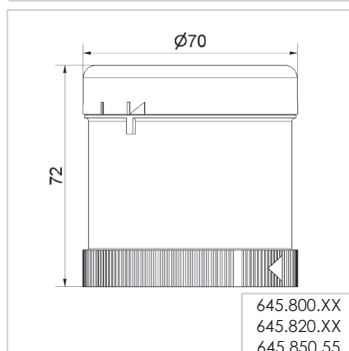

645.870.75
645.770.75
645.890.xx
645.790.xx



24 V

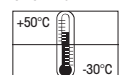

KombiSIGN 71 - Audible Elements



High output vocal element with up to 102 dB

TECHNICAL SPECIFICATIONS/ORDER SPECIFICATIONS:

Dimensions (Ø x Height)	See below	
Lens	PC	
Protection rating	IP 65	
Life duration	5,000 hrs	
Siren element with self-adjusting sound output		
Dimensions (Ø x Height)	70 mm x 111 mm	
Voltage	24 V DC	
Current consumption	< 150 mA	
Order no.	645 810 55	
Tone type	Pulse tone	
Tone frequency	2.5 kHz	
Sound output	80 dB (A) - max. 100 dB (A)	
Vocal element	88 dB (A)	102 dB (A)
Dimensions (Ø x Height)	70 mm x 111 mm	125 mm x 118 mm
Voltage	24 V DC	24 V DC
Current consumption	< 400 mA	< 400 mA
Order no.	645 840 55	645 860 55
Number of tiers	Max. 4 additional signal elements possible	
Sound output	Adjustable, up to 88 dB (A)	Adjustable, up to 102 dB
File Transfer	Via USB connection and provided software	
Possible data format	Mp3 and wav files	
Number of sequences	15 files can be remotely triggered depending on the number of signal elements used or one sequence with max. 50 files.	
Suitable for	Windows®, System requirements – see Handbook	
Assembly	Vocal element, USB connection cable and software	
Further Information	With UL approval	No UL approval

TECHNICAL DIAGRAMS:

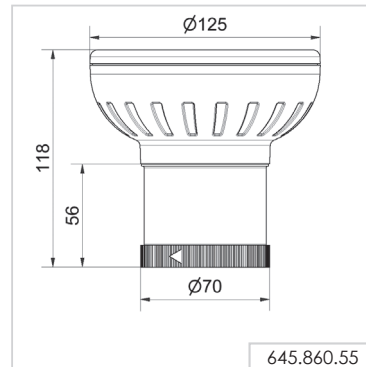
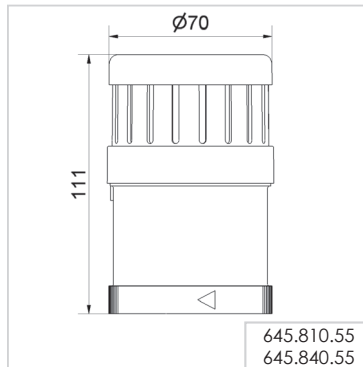

645.810.55
645.840.55

24 V



KombiSIGN 71 - Terminal Elements



Screw terminal with cap



Terminal element with practical M12 connection socket in base



① TECHNICAL SPECIFICATIONS/ORDER SPECIFICATIONS:

	Tube mounting	Base mounting
Dimensions (Ø x Height)	See below	
Housing	Terminal element: PA fibreglass Cap: PC	
Fixing	Base mounting Tube mounting, for tube Ø 25 mm Bracket mounting (accessory)	
Cable entry	Cable diameter max. 11 mm	
Protection rating	IP 65	
Number of modules possible	Max. 5	
Screw terminal	Tube mounting	Base mounting
Dimensions (Ø x Height)	70 mm x 42.5 mm	
Connection	Screw terminal max. 1.5 mm ²	
Voltage	12-240 V AC/DC	
Order no.	640 830 00	640 820 00
	Incl. cap	Incl. cap and seal
CAGE CLAMP® technology	Tube mounting	Base mounting
Dimensions (Ø x Height)	70 mm x 42.5 mm	
Connection	CAGE CLAMP® technology max. 1.5 mm ²	
Voltage	12-240 V AC/DC	
Order no.	640 810 00	640 800 00
	Incl. cap	Incl. cap and seal

Terminal element M12	8 pole (up to 5 tiers)	5 pole (up to 4 tiers)
Dimensions (Ø x Height)	70 mm x 59 mm	
Fixing	Tube and Base mounting	
Voltage	12-24 V DC	
Current carrying capacity	≤ 2 A	
Order no.	640 880 00	640 870 00
	Incl. cap and seal	

✂ ACCESSORIES:

Base with integrated tube	975 840 10
Base for tube (metal)	975 840 91
Tube Ø 25 mm, Aluminium eloxiert	
100 mm long	975 845 10
250 mm long	975 840 25
400 mm long	975 840 40
600 mm long	975 840 60
800 mm long	975 840 80
1000 mm long	975 840 03

Further accessories can be found on page 78.

↔ TECHNICAL DIAGRAMS: next page





Direct triggering of the signal tower elements via USB Interface

KombiSIGN 71 - USB Terminal Element

① TECHNICAL SPECIFICATIONS/ORDER SPECIFICATIONS:

Terminal element with USB Interface

Dimensions (Ø x Height)	70 mm x 36 mm
Fixing	Tube mounting
Connection	Via USB (Type B)
Voltage	Terminal element: Via USB (5 V DC)
Voltage	24 V DC
Current carrying cap. ΣI_{max}	90 mA at 24 V
Order no.	640 840 00
Assembly	Assembly includes installation software, drivers, handbook and USB connection cable (length 1.8 m)
Suitable for	Windows®, System requirements – see Handbook

- Direct triggering of signal tower elements via USB Interface
- Simple integration into any customer-specific software
- No additional power supply or hardware necessary
- Up to five signal towers with a maximum of five tiers each can be connected
- Maximum cable length 5m

↔ TECHNICAL DIAGRAMS:

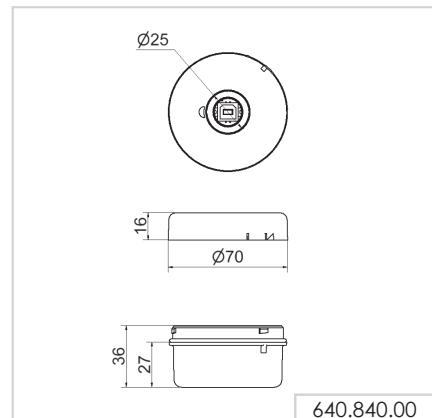
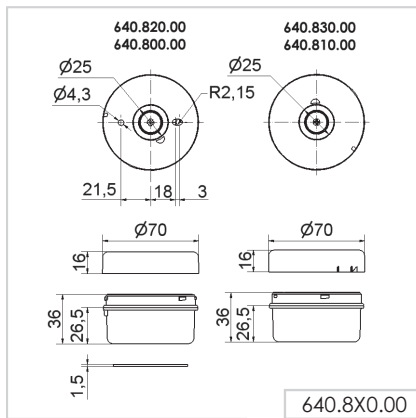
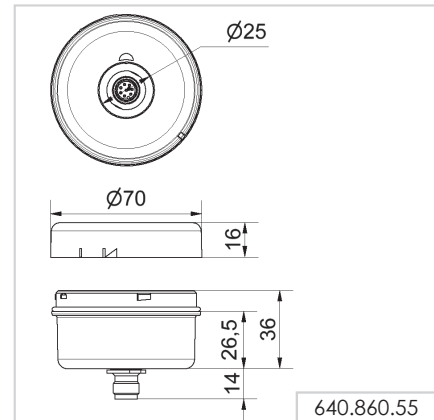
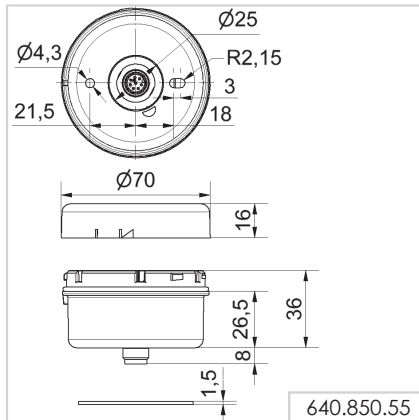

KombiSIGN 71 - AS-Interface Element



Cable not included in assembly



LEDs display the current status

① TECHNICAL SPECIFICATIONS/ORDER SPECIFICATIONS:

Specif. Power supply AS-Interface Element	Via bus conduction	
Operating voltage	18.5 V ... 31.6 V according to the AS-Interface specification	
Reverse battery protection	Integrated	
Watchdog	Integrated	
	Standard Slave	A/B-Slave
Number of addresses	Max. 31	Max. 62
Number of tiers	Max 4	Max. 3
IO-Code	8 _{Hex}	8 _{Hex}
ID-Code	F _{Hex}	A _{Hex}
ID2-Code	N/A	E _{Hex}
Outputs	4 semiconductor relays	3 semiconductor relays
Approved in accordance with	Spec. V 3.0	Spec. V 3.0
Order no.	646 830 55	646 810 55
	With internal add. voltage	With external add. voltage
Additional external voltage	24 V DC	24 V DC
Current carrying cap. Σ I _{max}	200 mA	200 mA per signal
Current consumption max	235 mA	≤ 50 mA
Voltage at signal element	20 V ... 30 V DC	24 V +/- 10%
Short circuit/overload protection	Integrated	Pre-fuse M 1.6 A

↔ TECHNICAL DIAGRAMS:

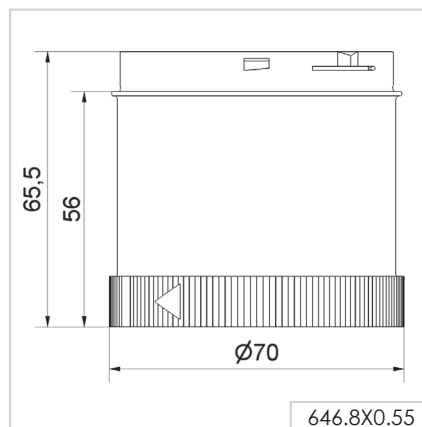



AndonLIGHT

Your benefits

The introduction to professional call-for-action systems: the easy-to-retrofit Andon products in combination with WERMA KombiSIGN 71 and KombiSIGN 72 signal towers. With these products it is easy to improve safety and efficiency in the workplace.

- Rapid assistance reduces waiting times
- Reduces response times and prevents shutdowns
- Intuitive and self-explanatory light system
- More reliability and efficiency (no running about, calling out, etc.)
- It can be expanded to a networked system at any time

Typical applications

- Professionally signal problems at workstations
- Manage supply of materials to workstations
- Optimise processes

Initial startup

- Simply connect AndonLIGHT with mains plug

Features

- Enables up to eight different statuses to be activated
- Signal directly on the signal tower with AndonCONTROL
- Activate signals on the signal tower with Andon SmartBOX



This is how you put together your AndonLIGHT system













ANDON PRODUCT		
Base mounting	Aluminium profile mounting/Wall mounting	
 <p>AndonCONTROL Order no. 860 640 07</p>	 <p>Andon SmartBOX incl. Power supply Order no. 860 000 09</p>	
SIGNAL TOWER		
SIGNAL ELEMENTS (UP TO A MAXIMUM OF 4)		PRE-CONFIGURED SIGNAL TOWER
		Base mounting
 Buzzer Order no. 645 800 75	 LED Permanent light blue Order no. 644 500 75	 LED Permanent light Order no. 649 240 02
 2 tone siren Order no. 645 870 75	 TwinLIGHT red Order no. 647 110 75	 LED Permanent light Order no. 649 240 05
 LED Permanent light red Order no. 644 100 75	 TwinLIGHT yellow Order no. 647 310 75	 LED Permanent light Order no. 649 240 04
 LED Permanent light green Order no. 644 200 75	 TwinLIGHT green Order no. 647 210 75	 LED Permanent light Order no. 649 240 06
 LED Permanent light yellow Order no. 644 300 75	 TwinLIGHT clear Order no. 647 430 75	 TwinLIGHT Order no. 649 000 01
 LED Permanent light clear Order no. 644 400 75	 TwinLIGHT blue Order no. 647 510 75	 TwinLIGHT Order no. 649 000 02
Base mounting	Tube mounting	Bracket mounting
 <p>Terminal element Order no. 640 800 00</p>	 <p>Terminal element + Base with integrated tube Order no. 640 810 00 + 975 840 10</p>	 <p>Terminal element + Bracket for base mounting Order no. 640 800 00 + 960 000 02</p>



AndonLIGHT - Pre-configured Signal Tower

Or select one of our pre-configured variants.



i TECHNICAL SPECIFICATIONS/ORDER SPECIFICATIONS:				
Pre-configured signal tower	KombiSIGN 71		KombiSIGN 72	
Order No.	649 260 01		649 000 03	
Consisting of		644 100 75		647 110 75
		+ 644 300 75		+ 647 310 75
		+ 644 200 75		+ 647 210 75
		+ 640 810 00		+ 640 810 00
		+ 975 840 10		+ 975 840 10
		+ 860 000 09		+ 860 000 09

Technical details are given on the relevant product page.

← TECHNICAL DIAGRAMS:

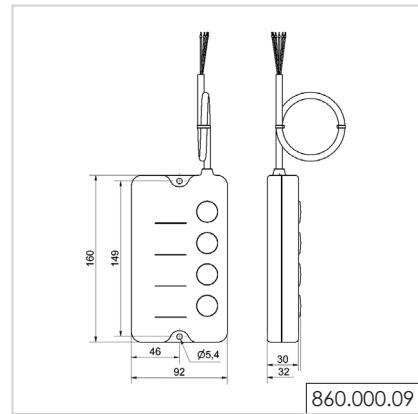
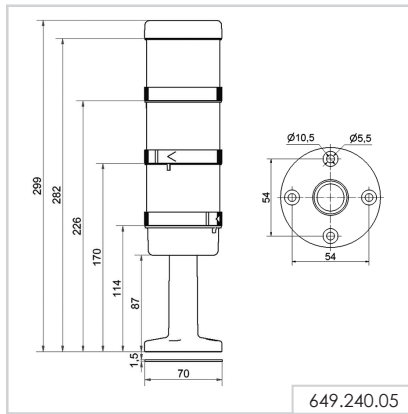

Andon SmartBOX for Signal Towers



Andon SmartBOX for use in industrial applications

① TECHNICAL SPECIFICATIONS/ORDER SPECIFICATIONS:

Dimensions (B x H x T)	161 mm x 79 mm x 138 mm
Housing	PA-GF Switches: PC
Fixing	Base mounting, Wall mounting
Connection	Via 5 m cable
Number of signal elements	Max. 4 additional signal elements possible
Assembly	Andon SmartBOX, power supply unit with connection cable (length 1.8 m), Adapter supplied (EU, UK, North America)
Voltage power supply unit	100-240 V AC
Voltage signal elements	24 V DC
Current consumption	Max. 1 A
Order no.	860 000 09

↔ TECHNICAL DIAGRAMS:

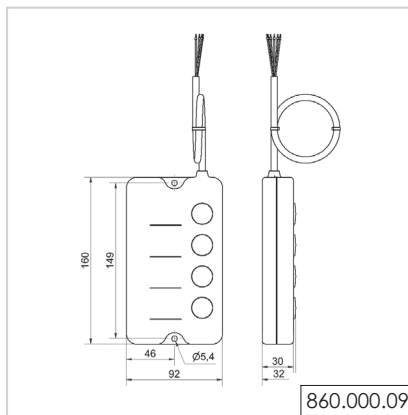

Interchangeable adaptors (included in assembly) and wide input voltage range make the Power Supply suitable for worldwide use





AndonCONTROL / Connection Set for KombiSIGN 72 and 71



AndonCONTROL is a simple call system for a wide variety of applications



The four push buttons can be individually labelled



With the aid of the connection set, the master/receiver from KombiSIGN reflect can be used wherever an electrical socket is available (see page 55)

① TECHNICAL SPECIFICATIONS/ORDER SPECIFICATIONS:

Dimensions (Ø x Height)	136 mm x 55 mm	
Housing	Base: PC/ABS Terminal element: PA-GF, shock resistant	
Fixing	Base mounting, Bracket mounting (accessory)	
Number of signal elements	Max. 4 additional signal elements possible	
Assembly	AndonCONTROL, power supply unit with connection cable (length 1.8 m), interchangeable adaptors for EU, UK, North America, rubber feet, cable connection	Connection Set, power supply unit with connection cable (length 1.8 m), interchangeable adaptors for EU, UK, North America, rubber feet, cable connection
Voltage power supply unit	115-230 V AC	115-230 V AC
Voltage signal elements	24 V DC	24 V DC
Current consumption	Max. 1 A	Max. 1 A
Order no.	860 640 07	860 640 08

✂ ACCESSORIES:

Mounting bracket, metal	975 883 01
-------------------------	-------------------

↔ TECHNICAL DIAGRAMS:

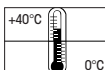
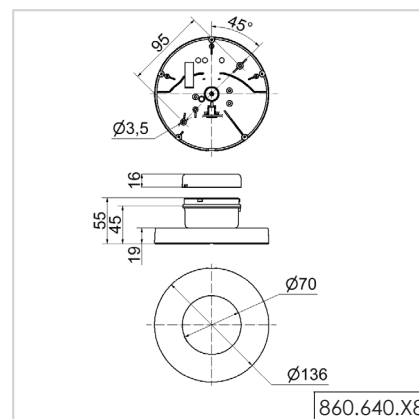
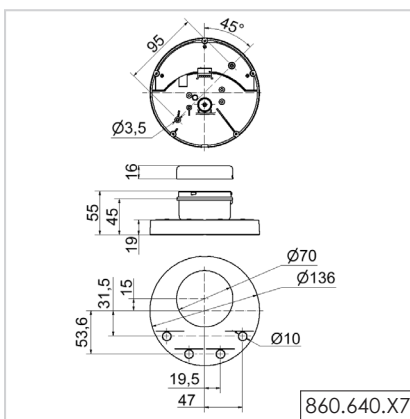

AndonWIRELESS

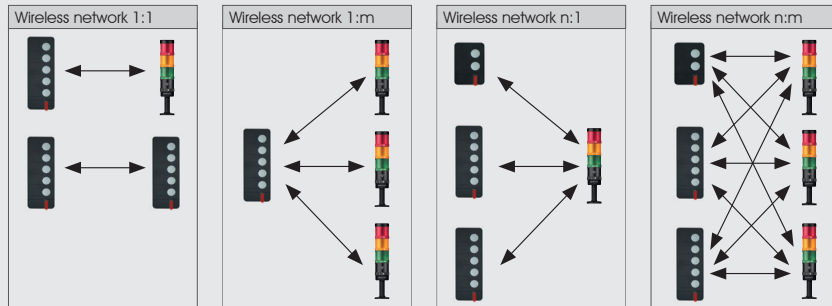

Your benefits

The WERMA AndonWIRELESS call for action system is the quick and easy way to report, display and rectify problems in a targeted manner. Have you been mainly been solving faults and problems by shouting over to colleagues or walking around to find or provide support? Using AndonWIRELESS, you can now report them professionally at the push of a button. The wireless connection between the buttons and signal towers makes installation easier and faster than ever before, saving you time and money. Every button (Andon WirelessBOX) can be operated using mains power or battery power. This allows you to use it as a stand-alone system for mobile applications, e.g. on forklifts or supply chain vehicles. Make sure your operation is ready for future requirements and flexible for greater efficiency in the workplace.

- Andon WirelessSET with 5-button box (Andon WirelessBOX) and 3-tier signal tower
- Andon WirelessSET with 2-button box (Andon WirelessBOX) and 2-tier signal tower

Configure your individual call for action system easily and conveniently using the Quickfinder.

Typical applications

- Professional reporting of workstation problems
- Material replenishment control with acknowledgement function
- Optimisation of processes in production and logistics departments
- Access control for doors and gates

Initial startup

- Configure the button box (Andon WirelessBOX) and receiver (transceiver)
- Power up the button box (Andon WirelessBOX) via the mains plug or battery
- Integrate the receiver (transceiver) into a signal tower without needing any tools

Features

- Andon WirelessBOX with 2 or 5 buttons
- Signal tower with 2 to 5 tiers
- Configurable button illumination
- Multifunctional acknowledgement function
- Transceiver for wireless signal reception
- Simple configuration software
- Can be combined with control station function: easy to upgrade to SmartMONITOR or AndonSPEED





How to assemble your individual Andon WirelessSET



Andon WirelessBOX incl. Power supply
 Order no. **860 000 16**
 Order no. **860 000 17**



Andon WirelessBOX incl. Power supply
 Order no. **860 000 18**
 Order no. **860 000 19**



Optional:
 Mounting tape
 Order no. **960 860 04**



Transceiver
 Order no. **862 000 03** (868 Mhz)
 Order no. **862 000 05** (921 Mhz)

Signal elements (up to maximum of 5)



Buzzer
 Order no. **645 800 75**



2 tone siren
 Order no. **645 870 75**



8 tone siren
 Order no. **645 890 75**



Vocal element
 Order no. **645 840 55**



TwinLIGHT red
 Order no. **647 110 75**



TwinLIGHT yellow
 Order no. **647 310 75**



TwinLIGHT green
 Order no. **647 210 75**



TwinLIGHT white
 Order no. **647 430 75**



TwinLIGHT blue
 Order no. **647 510 75**

Pre-configured signal tower

Base mounting



TwinLIGHT
 Order no. **649 000 01**

Tube mounting



TwinLIGHT
 Order no. **649 000 02**

Base mounting



Connection Set incl. Power supply
 Order no. **860 640 09**



Fixing bracket
 Order no. **975 883 01**

Tube mounting



Terminal element with plug
 Order no. **640 000 02**



Power supply incl. adapter
 Order no. **960 860 02**

Tube Ø 25 mm, all anodised
 Order no.
 100 mm long **975 845 10**
 250 mm long **975 840 25**
 400 mm long **975 840 40**
 600 mm long **975 840 60**
 800 mm long **975 840 80**
 1000 mm long **975 840 03**

Base for Tube, plastic
 Order no. **975 840 90**

Base for Tube, metal
 Order no. **975 840 91**

Foldable base
 Order no. **960 000 30**
 Order no. **960 009 12**

Base with integrated tube
 Order no. **975 840 10**



Strain relief for base with integrated tube
 Order no. **960 649 01**



Bracket for base mounting
 Order no. **960 000 14**



Winkel für tube mounting
 Order no. **960 000 01**



Bracket for wall mounting
 Order no. **960 000 02**



Bracket for 1-sided mounting
 Order no. **975 840 85**



Bracket for 2-sided mounting
 Order no. **975 840 86**



Bracket for base mounting
 Order no. **960 000 14**



Bracket for tube mounting
 Order no. **960 000 01**



Andon WirelessSET
 Basic 5 Button
 Order no. **649 000 13**



Andon WirelessSET
 Basic 2 Button
 Order no. **649 000 12**



Buzzer
 Order no. **645 800 75**

2 tone siren
 Order no. **645 870 75**

8 tone siren
 Order no. **645 890 75**

Vocal element
 Order no. **645 840 55**

TwinLIGHT red
 Order no. **647 110 75**

TwinLIGHT yellow
 Order no. **647 310 75**

TwinLIGHT green
 Order no. **647 210 75**

TwinLIGHT white
 Order no. **647 430 75**

TwinLIGHT blue
 Order no. **647 510 75**



Indication board
 Order no. **960 000 05**

KombiSIGN reflect for KombiSIGN 72 and 71



Your benefits

Do you have a machine or a workstation that is out of your line of sight? KombiSIGN reflect offers a simple solution that "reflects" the machine status to a KombiSIGN signal tower in your vicinity. The two elements are paired and ready for immediate use.

- Keep track of machines or processes that are out of view
- Reduce response times and prevent shutdowns
- Repair faults quickly
- Monitor machines/areas that are not yet networked

Typical applications

- Report stoppages in complex production areas
- Manage the supply of materials where visibility is restricted
- Improve processes in complex production areas

Initial startup

- Integrate transmitter and receiver into the signal towers (no tools necessary)

Features

- Pre-configured for plug & play
- Simple reflection of machine statuses
- Large transmission range thanks to robust wireless network for production environments





KombiSIGN reflect for KombiSIGN 72 and 71



The slave sends the status directly to the master, and reflects the status of the signal tower installed on the machine

① TECHNICAL SPECIFICATIONS/ORDER SPECIFICATIONS:

	Slave	Master
Dimensions (Ø x Height)	70 mm x 66 mm	70 mm x 66 mm (without antenna)
Housing	Polycarbonate, black	
Connection	Bayonet	
Wireless connection ISM frequency	868 MHz (conforms to the EU's EN 300220 harmonised standard and can thus be used in all EU member countries) Further countries upon request	
Transmission range	Up to 300 m (unobstructed line of sight)	
Operating voltage	24 V AC/DC	24 V DC
Current consumption	40 mA	40-900 mA
Order no.	861 640 01	

Please check the wireless frequency. In Europe the version with 868 MHz is used. Please enquire about use in other countries.

↔ TECHNICAL DIAGRAMS:



Simple monitoring of signal towers out of view

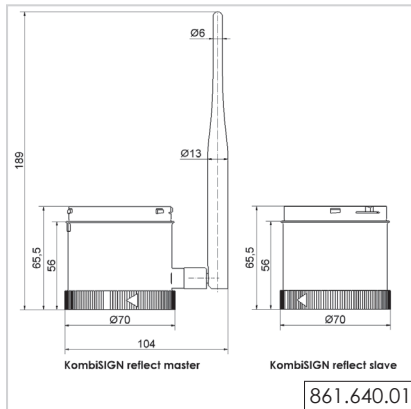

Simply fit the KombiSIGN reflect slave to the signal tower on the machine

861 X40 02
receiver: class 2





KombiSIGN reflect for KombiSIGN 72 and 71



The transmitter sends the status directly to the receiver, and reflects the status of the signal tower installed on the machine

TECHNICAL SPECIFICATIONS/ORDER SPECIFICATIONS:

	Transmitter	Receiver
Dimensions (Ø x Height)	70 mm x 66 mm	70 mm x 66 mm (without antenna)
Housing	Polycarbonate, black	
Connection	Bayonet	
Wireless connection	915 MHz (only for use in North America)	
ISM frequency	Further countries upon request	
Transmission range	Up to 300 m (unobstructed line of sight)	
Operating voltage	24 V AC/DC	24 V DC
Current consumption	40 mA	40-900 mA
Order no.	861 640 02	

In North America the version with 915 MHz is used. Please enquire about use in other countries.

TECHNICAL DIAGRAMS:



Simple monitoring of signal towers out of view

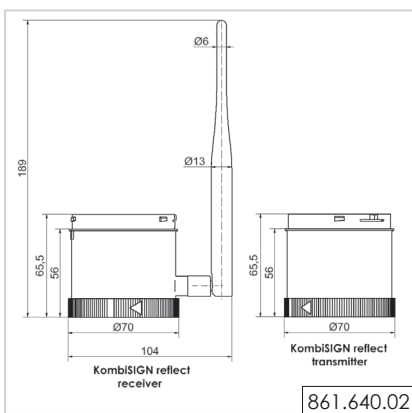

Simply fit the KombiSIGN reflect transmitter to the signal tower on the machine

861 X40 02
receiver: class 2





KOMPAKT 37 - pre-assembled Signal Tower

Your benefits

The KOMPAKT 37 is a completely pre-assembled signal tower that can be easily ordered under a single part number. With 1-5 visual tiers, the slim signal tower can be installed quickly and easily. The compact and completely enclosed construction is ideal for use in all types of public areas because it is tamper-proof.

- Up to six levels of signal escalation possible – including an audible signal
- In *ClassicLOOK* or *DesignLOOK* to suit all machine surfaces
- Clearly visible from all positions thanks to the *OmnivIEW* lens with no blind spots

Typical applications

Fault signalling

- on smaller machines and equipment
- on point-of-sale and access control systems

Installation options

- Single-hole mounting
- Additional installation options using accessories

Features

- Pre-assembled with easy cable connection or M12 plug for plug & play use



Size comparison KOMPAKT 37 / KombiSIGN 40



How to select your KOMPAKT 37 signal tower

► STEP 1

Select the signal tower of your choice with or without buzzer, with the appropriate connection, housing colour, voltage and number of tiers.

Part numbers can be found on page 60.



ClassicLOOK

- 12 or 24 V
- 1-5 tiers
- With or without buzzer
- M12 plug or cable
- Black or silver finish



DesignLOOK

► STEP 2

Select up to two extension tubes.

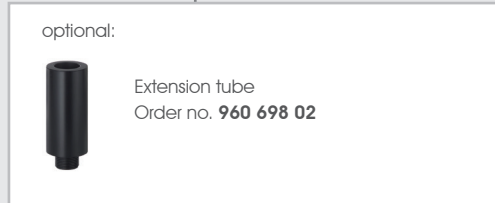

optional:

Extension tube
Order no. **960 698 02**

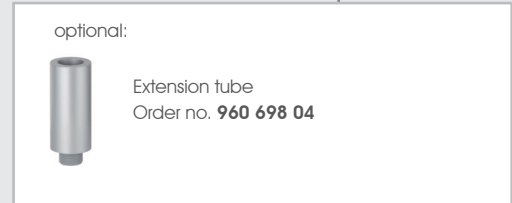

optional:

Extension tube
Order no. **960 698 04**

► STEP 3

Select the appropriate fixing accessories for your application, using for example a tube and base or a bracket mount.

Single Hole Mounting

Bracket Mounting

Base Mounting

Single Hole Mounting

Bracket Mounting

Base Mounting

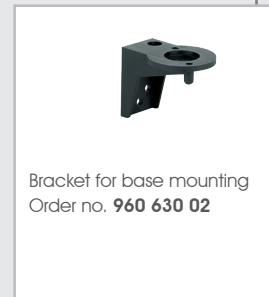

Bracket for base mounting
Order no. **960 630 02**

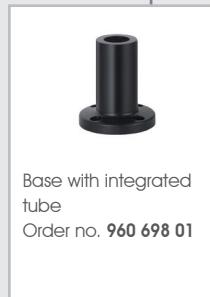

Base with integrated tube
Order no. **960 698 01**

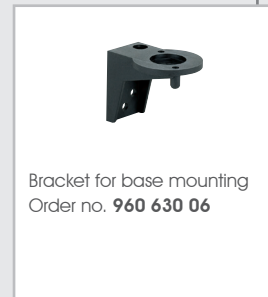

Bracket for base mounting
Order no. **960 630 06**

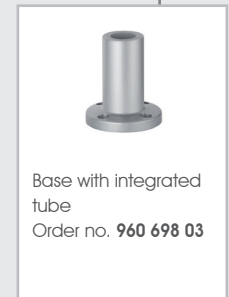

Base with integrated tube
Order no. **960 698 03**

► STEP 4

Where appropriate, select the bracket and the contact box.

	Bracket for base mounting with concealed cable entry Order no. 960 000 14		Contact box with magnetic base and cable exit at side Order no. 975 840 04
	Bracket for base mounting Order no. 960 000 01		Bracket for base mounting with concealed cable entry Order no. 960 000 55
	Corner fixing bracket Order no. 960 000 41		Bracket for base mounting Order no. 960 000 54
	Contact box for cable exit at side Order no. 975 840 01		

Go to the signal devices page on: www.werma.com

Here you can use the selection tool „Configurator“ to select the Kompakt 37 signal tower according to your requirements.

With the help of intuitive questions and pictures you will be able to make your choice with just a few mouse clicks.



KOMPAKT 37 - pre-assembled Signal Tower



ClassicLOOK



Two tier Kompakt 37 with integral tube and base (accessory)



Three tier Kompakt 37 with bracket (accessory)

① TECHNICAL SPECIFICATIONS/ORDER SPECIFICATIONS:

Dimension (Ø x Height)	1 tier: 37.5 mm x 93.5 mm 2 tier: 37.5 mm x 127.5 mm 3 tier: 37.5 mm x 161.5 mm 4 tier: 37.5 mm x 195.5 mm 5 tier: 37.5 mm x 229.5 mm (Protrusion from panel)
Housing	PC
Fixing	Single hole mounting for Ø 22.5 mm (M22 x 1.5 mm) Base or bracket mounting (accessory)
Connection	Cable connection: Cable, 2 m long, Plug connection: M12 Plug (1/2/3 tier: 5 pole; 4/5 tier: 8 pole)
Current consumption	50 mA per tier / buzzer 24 V 125 mA per tier / buzzer 12 V

Nut and seal included in assembly.

ClassicLOOK with buzzer		Connection	24 V AC/DC	
1 tier	red	Plug	699 610 75	
	yellow	Plug	699 630 75	
2 tier	green/red	Cable	699 120 75	
	yellow/red	Cable	699 130 75	
	green/red	Plug	699 220 75	
	yellow/red	Plug	699 230 75	
3 tier	green/yellow/red	Cable	699 110 75	
	green/yellow/red	Plug	699 210 75	
4 tier	clear/green/yellow/red	Cable	699 140 75	
	blue/green/yellow/red	Cable	699 150 75	
	clear/green/yellow/red	Plug	699 240 75	
	blue/green/yellow/red	Plug	699 250 75	
5 tier	blue/clear/green/yellow/red	Cable	699 160 75	
	blue/clear/green/yellow/red	Plug	699 260 75	
ClassicLOOK without buzzer		Connection	24 V AC/DC	12 V AC/DC
2 tier	green/red	Cable	698 120 75	698 120 74
	yellow/red	Cable	698 130 75	-
	green/red	Plug	698 220 75	-
	yellow/red	Plug	698 230 75	-
3 tier	green/yellow/red	Cable	698 110 75	698 110 74
	green/yellow/red	Plug	698 210 75	-
4 tier	clear/green/yellow/red	Cable	698 140 75	-
	blue/green/yellow/red	Cable	698 150 75	-
	clear/green/yellow/red	Plug	698 240 75	-
	blue/green/yellow/red	Plug	698 250 75	-
5 tier	blue/clear/green/yellow/red	Cable	698 160 75	-
	blue/clear/green/yellow/red	Plug	698 260 75	-
DesignLOOK with buzzer		Connection	24 V AC/DC	
1 tier	red	Plug	699 810 75	
	yellow	Plug	699 830 75	
2 tier	green/red	Cable	699 320 75	
	yellow/red	Cable	699 330 75	
	green/red	Plug	699 420 75	
	yellow/red	Plug	699 430 75	
3 tier	green/yellow/red	Cable	699 310 75	
	green/yellow/red	Plug	699 410 75	

DesignLOOK



The height of the KOMPAKT 37 can be increased by max. 160 mm with the use of extension tubes, ensuring optimum visibility

① TECHNICAL SPECIFICATIONS/ORDER SPECIFICATIONS:

DesignLOOK with buzzer		Connection	24 V AC/DC
4 tier	clear/green/yellow/red	Cable	699 340 75
	blue/green/yellow/red	Cable	699 350 75
	clear/green/yellow/red	Plug	699 440 75
	blue/green/yellow/red	Plug	699 450 75
5 tier	blue/clear/green/yellow/red	Cable	699 360 75
	blue/clear/green/yellow/red	Plug	699 460 75
DesignLOOK without buzzer		Connection	24 V AC/DC
2 tier	green/red	Cable	698 320 75
	yellow/red	Cable	698 330 75
	green/red	Plug	698 420 75
	yellow/red	Plug	698 430 75
3 tier	green/yellow/red	Cable	698 310 75
	green/yellow/red	Plug	698 410 75
4 tier	clear/green/yellow/red	Cable	698 340 75
	blue/green/yellow/red	Cable	698 350 75
	clear/green/yellow/red	Plug	698 440 75
	blue/green/yellow/red	Plug	698 450 75
5 tier	blue/clear/green/yellow/red	Cable	698 360 75
	blue/clear/green/yellow/red	Plug	698 460 75

✳ ACCESSORIES:

	ClassicLOOK	DesignLOOK
Base with integrated tube	960 698 01	960 698 03
Extension tube	960 698 02	960 698 04
Cable 5 m with M12 plug (5 pole)		960 693 05
Cable 5 m with M12 plug (8 pole)		960 000 47
Cable 5 m with M12 connector and plug (8 pole)		960 000 46
Bracket for base mounting	960 698 05	-

Further accessories can be found on page 74.

↔ TECHNICAL DIAGRAM:

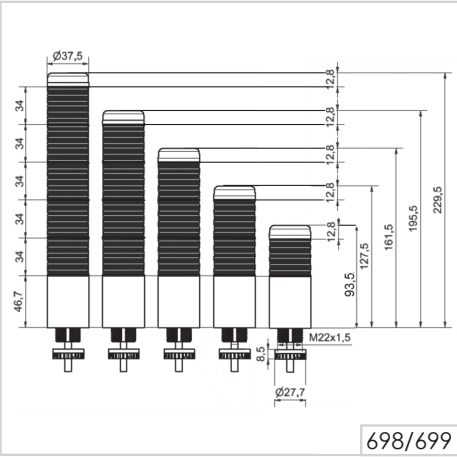

Class 2

699

--	--	--	--	--	--	--	--





eSIGN - electronic modular signal tower

Your benefits

The new eSIGN brings new dimensions to light. Electronic modularity enables the product to create a variety of signal modes with various colours, brightness levels and light effects, from the classic signal tower to completely customised settings. eSIGN can also switch with ease between variable filling level indications or full-surface signalling. In addition to providing you with an overview of your process cycles, this also opens up completely new options.

- Full-surface signalling: Clear, unmistakable light effects for maximum visibility
- Versatile customisation options: Different modes, light effects and tones for diverse applications
- Robust industrial design: UL Type 4X ensures resistance to UV radiation and environmental influences
- The right product for every application: 2 sizes, with/without siren, 24 V supply voltage / versions with IO-Link technology, black/white housing

Typical applications

The new definition of the industry standard to signal faults

- on machinery and equipment
- on automated systems
- in assembly plants, for example, in the automotive industry
- on conveyor belts in production and logistics

Installation options

- Base mounting, Wall mounting, Tube mounting

Features

- Classic signal tower indication in individual tiers
- Autoscale mode for full-surface signalling and optimum visibility
- Variable filling level indication from 0 to 100 %
- Individual triggering to suit your requirements
- 9 or 15 segments, freely triggerable
- With or without siren
- Standard 24 V version with transfer of the configuration via USB
- Version with IO-Link technology
- M12 connection
- Duration of the acoustic warning adjustable
- A specific acoustic warning can be assigned to each optical warning
- Fraunhofer IPA approval, fulfills Air Cleanliness Class 2 for Cleanroom applications in accordance with DIN EN ISO 14644-1

Size comparison ClearSIGN / KombiSIGN 72



eSIGN - ProfiNET



eSIGN with 15 segments



eSIGN with 9 segments



eSIGN with 6 segments

TECHNICAL SPECIFICATIONS/ORDER SPECIFICATIONS:

	15 segments	9 segments	6 segments
Dimensions (Ø x Height)	72,5 mm x 371,5 mm	72,5 mm x 271 mm	72,5 mm x 219 mm
Housing	PC		
Lens colour/Housing colour	clear/black		
Fixing	Base mounting, wall mounting, tube mounting		
Connections	M12 female connector (4-pin), D-coded		
Light effects	LED/Multicolour, various colours configurable Permanent, blinking, flashing, double flash, triple flash, rotating		
Tone types	Multi-tone, 10 tones are configurable		
Volume	max. 105 dB (A), 4 stages / 80-105 dB (A) depending on tone type		
Voltage	PoE 48V DC		
Current consumption	PoE and PoE+		
Order no.	657 600 56	657 100 56	657 430 56

ACCESSORIES

Tube Ø 25 mm, all anodised 100 mm long	975 845 10
250 mm long	975 840 25
Base for tube, plastic	975 840 90
Base for tube, metal	975 840 91
Base with integrated tube	960 000 64
Bracket for 1-sided mounting	960 000 65
Bracket for base mounting	960 000 01
Corner fixing bracket	960 000 41

Further accessories can be found on page 78.

TECHNICAL DIAGRAMS:

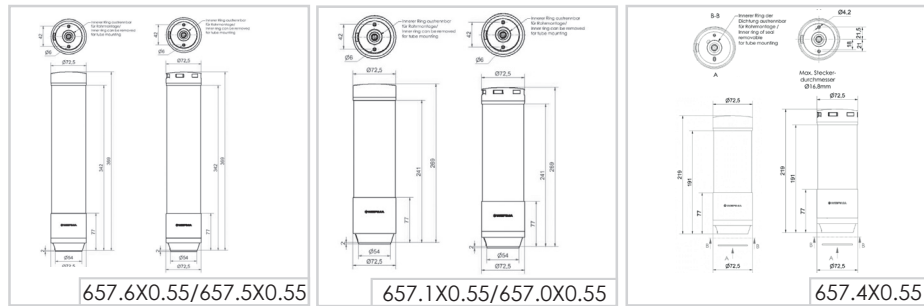



eSIGN - black



eSIGN with 15 segments



eSIGN with 9 segments



eSIGN with 6 segments

① TECHNICAL SPECIFICATIONS/ORDER SPECIFICATIONS:

	15 segments	9 segments	6 segments
Dimensions (Ø x Height)	72,5 mm x 371,5 mm	72,5 mm x 271 mm	72,5 mm x 219 mm
Housing	PC		
Lens colour/ Housing colour	clear/black		
Fixing	Base mounting, wall mounting, tube mounting		
Connections	M12 connector 4 pole (IO Link) 8 pole (standard 24 V)		
Light effects	LED/Multicolour, various colours configurable Permanent, blinking, flashing, double flash, triple flash, rotating		
Tone types	Multi-tone, 10 tones are configurable		
Volume	max. 105 dB (A), 4 stages / 80-105 dB (A) depending on tone type		
Voltage	24 V DC	24 V DC	24 V DC
Current consumption	620 mA (with siren) 555 mA (without siren)	405 mA (with siren) 335 mA (without siren)	325 mA (with siren) 255 mA (without siren)
With siren			
24 V	657 600 55	657 100 55	657 430 55
IO Link	657 610 55	657 110 55	657 450 55
Without siren			
24 V	657 500 55	657 000 55	657 420 55
IO Link	657 510 55	657 010 55	657 440 55

✂ ACCESSORIES

Tube Ø 25 mm, all anodised 100 mm long	975 845 10
250 mm long	975 840 25
Base for tube, plastic	975 840 90
Base for tube, metal	975 840 91
Base with integrated tube	960 000 64
Bracket for 1-sided mounting	960 000 65
Bracket for base mounting	960 000 01
Corner fixing bracket	960 000 41
Cable 5m with M12 connector and plug	960 000 46
Cable 5m with M12 plug	960 000 47
USB cabel type C to type A 0,5m (for transferring the configuration)	960 000 69
Further accessories can be found on page 74.	

↔ TECHNICAL DIAGRAMS:

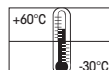
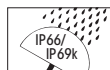
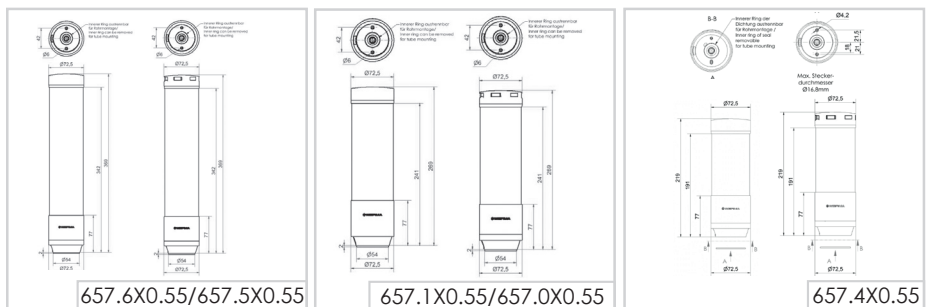

eSIGN - white



eSIGN with 15 segments



eSIGN with 9 segments



eSIGN with 6 segments

① TECHNICAL SPECIFICATIONS/ORDER SPECIFICATIONS:

	15 segments	9 segments	6 segments
Dimensions (Ø x Height)	72,5 mm x 371,5 mm	72,5 mm x 271 mm	72,5 mm x 219 mm
Housing	PC		
Lens colour/ Housing colour	clear/white		
Fixing	Base mounting, wall mounting, tube mounting		
Connections	M12 connector 4 pole (IO Link) 8 pole (standard 24 V)		
Light effects	LED/Multicolour, various colours configurable Permanent, blinking, flashing, double flash, triple flash, rotating		
Tone types	Multi-tone, 10 tones are configurable		
Volume	max. 105 dB (A), 4 stages / 80-105 dB (A) depending on tone type		
Voltage	24 V DC	24 V DC	24 V DC
Current consumption	620 mA (with siren) 555 mA (without siren)	405 mA (with siren) 335 mA (without siren)	325 mA (with siren) 255 mA (without siren)
With siren			
24 V	657 800 55	657 300 55	657 930 55
IO Link	657 810 55	657 310 55	657 950 55
Without siren			
24 V	657 700 55	657 200 55	657 920 55
IO Link	657 710 55	657 210 55	657 940 55

✂ ACCESSORIES

Tube Ø 25 mm, all anodised 100 mm long	975 845 10
250 mm long	975 840 25
Base for tube, plastic	975 840 90
Base for tube, metal	975 840 91
Base with integrated tube	960 000 64
Bracket for 1-sided mounting	960 000 65
Bracket for base mounting	960 000 01
Corner fixing bracket	960 000 41
Cable 5m with M12 connector and plug	960 000 46
Cable 5m with M12 plug	960 000 47
USB cable type C to type A 0,5m (for transferring the configuration)	960 000 69
Further accessories can be found on page 74.	

↔ TECHNICAL DIAGRAMS:

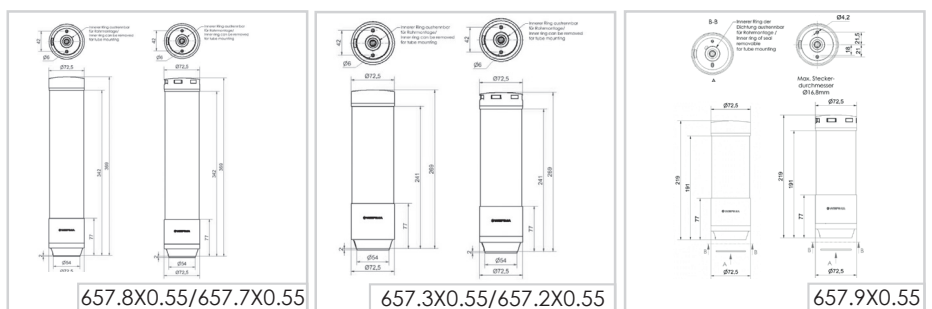



RST 56 - pre-assembled Signal Tower

Your Benefits

The new "RST" LED signal towers from WERMA impress with their modern, sleek appearance, outstanding performance and versatile application options. With its integrated design, it not only offers a refined and attractive appearance, but also homogeneous illumination and optimum visibility of the illuminated signals in all directions.

The aesthetic signal tower also impresses with sophisticated features, a compact, slim diameter of 57 mm, multiple mounting options and a high protection rating of IP 66 / IP 69k.

- Modern & robust industrial design
- 2 to 5 tiers
- 360° visibility - no blind spots
- Buzzer: Maximum 90 dB
- Can be connected via cable or M12
- Tamper-proof for public areas
- The IP66/IP69K degree of protection enables use in a wide range of environments

Typical applications

Signalling faults

- on machines and systems
- on automation systems
- on assembly systems, e.g. in the automotive industry
- on conveyor belts in production and logistics

Installation options

- Base/pipe mounting
- flush mounting
- Other mounting types possible via accessories

Features

- Homogeneous light pattern
- Compact design ensures space-saving installation



RST 56 - Base/Tube mounting



4 tier RST 56 for base and tube mounting



2 tier RST 56 for base and tube mounting

① TECHNICAL SPECIFICATIONS/ORDER SPECIFICATIONS

	Base or Tube mounting	
Dimensions (Ø x Height)	2 tier: 57 mm x 156 mm 3 tier: 57 mm x 196 mm 4 tier: 57 mm x 236 mm 5 tier: 57 mm x 276 mm	
Housing	PC/ABS	
Lens/Housing	transparent/black	
Light effects	LED Permanent light	
Tone type	Continuous tone, Pulse tone	
Sound output	82 or 90 dB (A), adjustable via dip switch	
Voltage	24 V DC	
With buzzer	Push-in terminals (24 V)	Current consumption
green, red	686 260 35	100 mA
green, yellow, red	686 370 35	150 mA
blue, green, yellow, red	686 480 35	185 mA
white, blue, green, yellow, red	686 590 35	230 mA
Without buzzer	Push-in terminals (24 V)	Current consumption
green, red	686 260 05	70 mA
green, yellow, red	686 370 05	125 mA
blue, green, yellow, red	686 480 05	160 mA
white, blue, green, yellow, red	686 590 05	205 mA

✂ ACCESSORIES

Tube Ø 25 mm, all anodised , 100 mm long	975 845 10
250 mm long	975 840 25
Base for Tube, plastic	975 840 90
Base for Tube, metal	975 840 91
Base with integrated tube	960 000 64
Bracket for base mounting with concealed cable entry	960 000 14
Bracket for tube mounting	960 000 01
Corner fixing bracket	960 000 41
Further accessories can be found from page 80.	

↔ TECHNICAL DIAGRAM

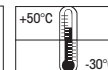
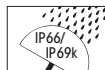
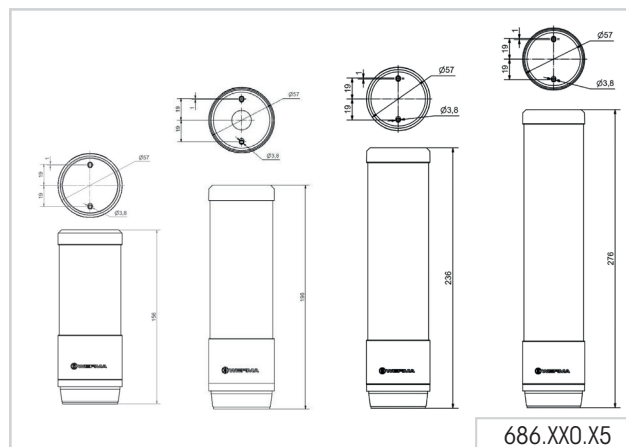



2 tier RST 56
for installation mounting



5 tier RST 56
for installation mounting

RST 56 - Installation mounting

① TECHNICAL SPECIFICATIONS / ORDER SPECIFICATIONS

		Installation mounting	
Dimensions (Ø x Height)		* (Protrusion from panel)	
		2 tier: 57 mm x 135 mm*	
		3 tier: 57 mm x 175 mm*	
		4 tier: 57 mm x 215 mm*	
		5 tier: 57 mm x 255 mm*	
Housing	PC/ABS		
Lens/Housing	transparent/black		
Light effects	LED Permanent light		
Tone type	Continuous tone		
Sound output	90 dB (A)		
Voltage	24 V DC		
With buzzer	M12 connector	Current consumption	
green, red	686 263 15	100 mA	
green, yellow, red	686 373 15	150 mA	
blue, green, yellow, red	686 483 15	185 mA	
white, blue, green, yellow, red	686 593 15	230 mA	
Without buzzer	M12 connector	Current consumption	
green, red	686 263 05	70 mA	
green, yellow, red	686 373 05	125 mA	
blue, green, yellow, red	686 483 05	160 mA	
white, blue, green, yellow, red	686 593 05	205 mA	

✂ ACCESSORIES

Fixing bracket	960 009 32
5m cable with M12 socket	960 693 05

↔ TECHNICAL DIAGRAM

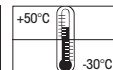
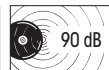
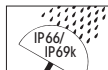
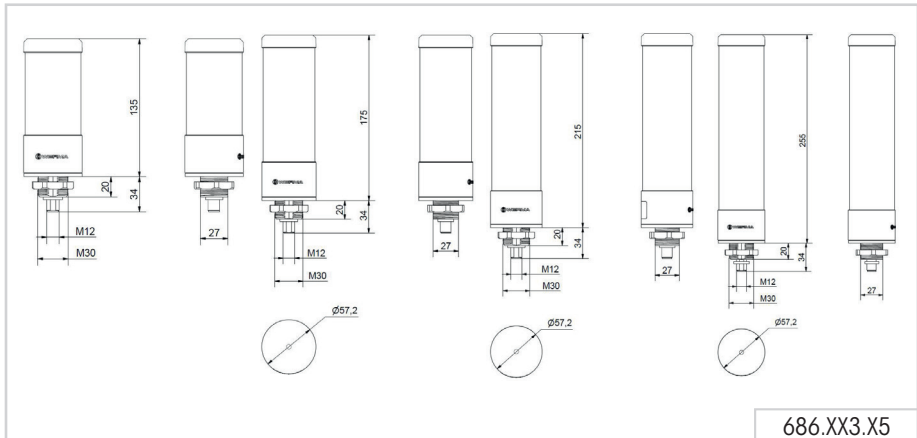

RST 56 - Pre-configured signal tower - Tube mounting



3 tier
pre-configured RST 56

① TECHNICAL SPECIFICATIONS/ORDER SPECIFICATIONS

	Tube mounting	
Dimensions (Ø x Height)	3 tier: 57 mm x 286 mm	
Housing	PC/ABS	
Lens/Housing	transparent/black	
Light effects	LED Permanent light	
Tone type	Continuous tone, Pulse tone	
Sound output	82 or 90 dB (A), adjustable via dip switch	
Voltage	24 V DC	
With buzzer	Push-in terminals (24 V)	Current consumption
green, yellow, red	686 371 35	150 mA
Without buzzer	Push-in terminals (24 V)	Current consumption
green, yellow, red	686 371 05	125 mA

✂ ACCESSORIES

Bracket for base mounting with concealed cable entry	960 000 14
Bracket for base mounting	960 000 01
Corner fixing bracket	960 000 41

↔ TECHNICAL DIAGRAM

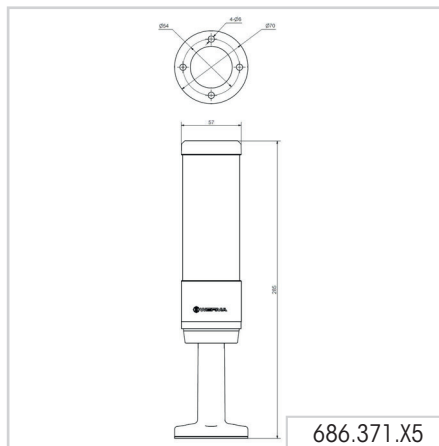



deSIGN 42 - pre-assembled Signal Tower

Your benefits

Thanks to its high-quality stainless steel housing, the deSIGN 42 signal tower is an ideal accompaniment to modern, design-oriented assembly lines, production facilities and machinery. The robust housing provides the key benefit of being tamper-proof for installations in public areas.

- Elegant industrial design
- Tamper-proof for public areas

Typical applications

Fault signalling

- on machinery and equipment

Access control

- on control points in public areas

Installation options

- Single-hole mounting
- Bracket mounting using accessories

Features

- High-quality, robust stainless-steel housing
- Award-winning design



Size comparison deSIGN 42 / KombiSIGN 72

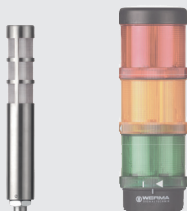



① TECHNICAL SPECIFICATIONS/ORDER SPECIFICATIONS:

	2 tier	3 tier
Dimensions (Ø x Height)	42 mm x 221 mm	42 mm x 255 mm
Housing	Stainless steel, brushed	
Fixing	Installation mounting for Ø 22.5 mm (M22 x 1.5 mm)	
Connection	Cable, 2 m long, included in assembly	
Voltage	24 V DC	24 V DC
Current consumption	50 mA per tier	50 mA per tier
red/green	694 010 55	-
red/yellow	694 020 55	-
red/yellow/green	-	694 000 55

✂ ACCESSORIES:

Surface housing single	975 109 02
Bracket, stainless steel (Protection rating IP 33)	960 694 01

← TECHNICAL DIAGRAMS:

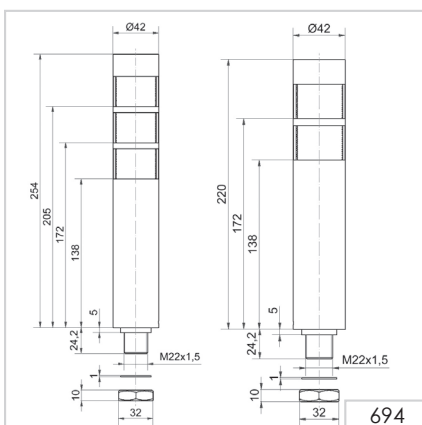



CleanSIGN - pre-assembled Signal Tower

Your benefits

The CleanSIGN signal tower has been specifically developed and certified for use in clean rooms, food and hygiene areas as well as the pharmaceutical industry. The signal tower ensures maximum safety in these environments by reducing the risk of contamination.

- Reliable signalling even in clean rooms
- Easy-to-clean, hygienic design for optimal cleaning and disinfection
- Ensures food safety through the absence of uneven surfaces, elevated or countersunk elements where dirt can accumulate
- Use of food safe materials (FDA approved) and resistant to cleaning agents
- Application-specific selection of colours and light effects for maximum flexibility

Typical applications

Fault signalling

- in clean rooms, e.g. semiconductor and solar industries
- in the food and beverage industry
- in pharmaceutical and cosmetic industries

Installation options

- Base mounting
- Ceiling mounting
- Wall mounting

Features

- Fraunhofer IPA approval
 - » Bracket mounting fulfills Air Cleanliness Class 1 for Cleanroom applications in accordance with DIN EN ISO 14644-1
 - » Base or Ceiling mounting fulfills Air Cleanliness Class 1
- Electronic modularity of the individual tiers (colour and light effects individually adjustable/ can be externally triggered)



Size comparison CleanSIGN / KombiSIGN 72





Fixed, three tier colour distribution in red, yellow and green

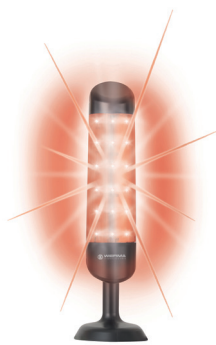

The "EVS" light effect ensures a maximum attention-grabbing effect (can be set with complete illumination)

① TECHNICAL SPECIFICATIONS/ORDER SPECIFICATIONS:

	Wall mounting	Base/Ceiling mounting
Dimensions (L x H x W)	112 mm x 485 mm x 125 mm	112 mm x 391 mm x 125 mm
Housing	PA, black	
Lens	PA, transparent	
Fixing	Wall mounting, integrated mounting bracket	Base mounting, Ceiling mounting
Sound output	85 dB (A)	
CleanSIGN red/green/yellow		
Connection	Cable, 2 m long, included in the assembly	
Colours	Pre-set colours: red/yellow/green	
Voltage	24 V DC	
Current consumption	Optical: < 120 mA per tier Buzzer: < 20 mA	
Order no.	695 300 55	695 310 55
CleanSIGN RGY		
Connection	Screw terminal max. 1.5 mm ²	
Colours	Colours selectable by dip-switch: red/yellow/green	
Voltage	24 V DC	
Current consumption	Optical: < 240 mA Buzzer: < 20 mA	
Order no.	695 200 55	695 210 55
CleanSIGN RGB		
Connection	Screw terminal max. 1.5 mm ²	
Colours	Red, yellow, green, white, blue, violet, turquoise Colours selectable by dip-switch	
Light effects	Tier-by-tier illumination: Blinking light Complete illumination: EVS	
Voltage	24 V DC	
Current consumption	Optical: < 240 mA Buzzer: < 20 mA	
Order no.	695 000 55	695 010 55

↔ TECHNICAL DIAGRAMS:

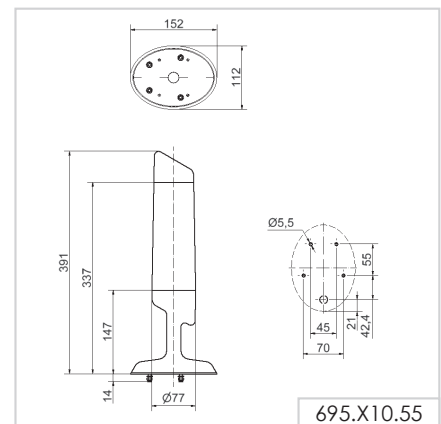
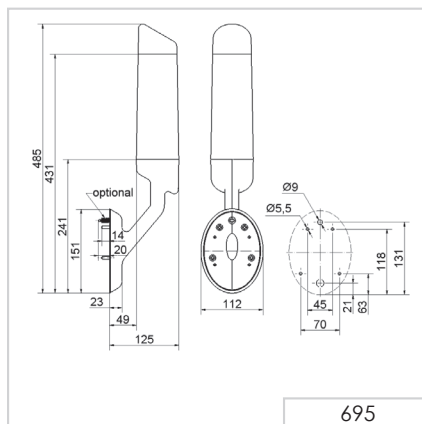



FlatSIGN - pre-assembled Signal Tower

Your benefits

The curved front of the FlatSIGN signal tower housing enables it to blend in uniformly with machine and building service applications. The 160-degree visibility angle ensures exceptional visibility even from the side.

- Easy to install – also on flush-mount enclosures
- TwinLIGHT combines two easily selectable light effects

Typical applications

Fault signalling or Access control

- in building service applications (e.g. server and equipment rooms)
- at access points in public areas

Installation options

- Wall mounting
- Additional installation options using accessories

Features

- Permanent or blinking light selectable
- Available with transparent housing or in metal design
- Optional integrated audible signal

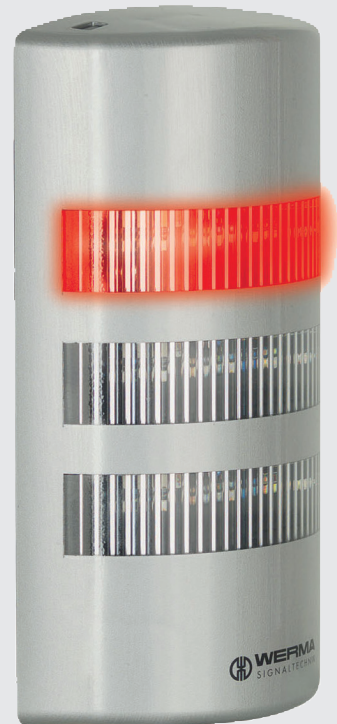

TwinLIGHT

Size comparison FlatSIGN / KombiSIGN 72





In its inactive state, the signal tower blends into the background thanks to its colourless, translucent housing



FlatSIGN in metallic finish



The fixing kit consists of two tube clamps and an adaptor (accessory)

① TECHNICAL SPECIFICATIONS/ORDER SPECIFICATIONS:

	Multi-tone Sounder	Buzzer (Continuous tone)
Dimensions (L x H x W)	105 mm x 195 mm x 45 mm	
Lower part	PC-ABS, black	
Upper part	PC, transparent or silver	
Fixing	Wall mounting	
Cable entry	Cable diameter max. 11 mm	
Connection	Screw terminal max. 1.5 mm ²	
Light effects	Permanent or blinking light selectable	
Audible signal	Buzzer or multi-tone sounder (8 tones)	
Sound output	Max. 80 dB (A)	
Colours:	Green, yellow, red	
Voltage	24 V DC	115-230 V AC
Current consumption	Optical: 30 mA per tier Audible: 30 mA	
FlatSIGN with transparent housing		
FlatSIGN without audible signal	691 100 55	691 100 68
FlatSIGN with audible signal	691 200 55	691 200 68
FlatSIGN in Metal Design		
FlatSIGN without audible signal	691 300 55	691 300 68
FlatSIGN with audible signal	691 400 55	691 400 68

✂ ACCESSORIES:

Fixing Kit	975 691 01
------------	-------------------

↪ TECHNICAL DIAGRAMS:

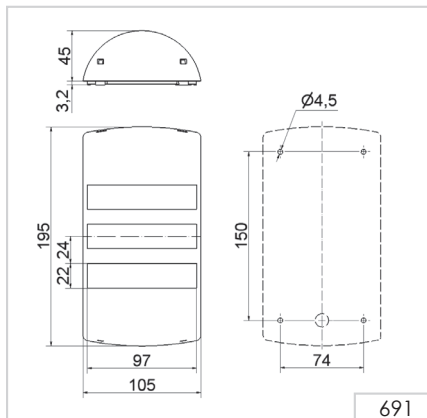

691.X00.55





VarioSIGN - pre-assembled Signal Tower

Your benefits

With the VarioSIGN light effects and colours can be individually set and adjusted via dip-switches at any time - depending on the variant. The eye-catching illumination of the entire lighting body ensures an exceptional appearance and visibility.

- Flexible selection of colours and light effects
- Award-winning design

Typical applications

Fault signalling

- on machinery and equipment
- on automation systems

Installation options

- Base mounting

Features

- Optional integrated sounder
- Electronic modularity: i.e. colours and light effects are adjustable for each tier

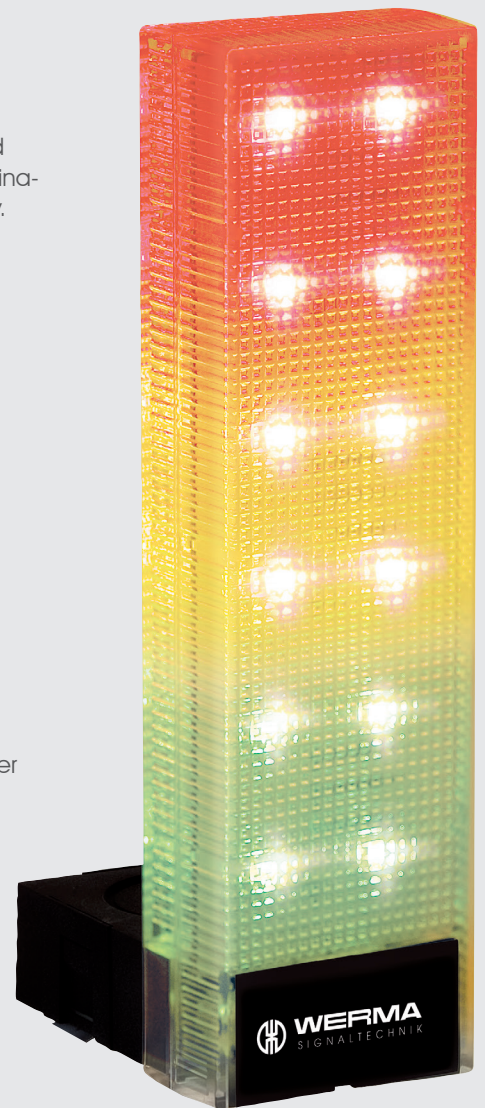

Size comparison VarioSIGN / KombiSIGN 72





Fixed, three-tier colour distribution in red, yellow and green



The "EVS" light effect ensures a maximum attention-grabbing effect (single colour distribution can be selected)

① TECHNICAL SPECIFICATIONS/ORDER SPECIFICATIONS:

	With buzzer	Without buzzer
Dimensions (L x H x W)	62 mm x 220 mm x 90 mm	
Housing	PC/ABS-Blend, black	
Lens	PC, transparent	
Fixing	Base mounting	
Cable entry	Cable diameter max. 11 mm	
Connection	Screw terminal max. 1.5 mm ²	
VarioSIGN - red/yellow/green		
Colours	Pre-set colours (red/yellow/green)	
Voltage	24 V DC	
Current consumption	Optical: < 55 mA per tier Buzzer: < 20 mA	
2-sided	690 300 55	690 320 55
VarioSIGN - RGY		
Colours	Red, yellow, green Colours selectable by Dip-switch	
Voltage	24 V DC	
Current consumption	Optical: < 120 mA Buzzer: < 20 mA	
2-sided	690 200 55	690 220 55
VarioSIGN - RGB		
Colours	Red, yellow, green, white, blue, violet, turquoise Colours selectable by Dip-switch	
Light effects	Tier-by-tier illumination: Flashing light Complete illumination: EVS	
Voltage	24 V DC	
Current consumption	Optical: < 300 mA Buzzer: < 20 mA	
2-sided	690 000 55	-

↔ TECHNICAL DIAGRAMS:

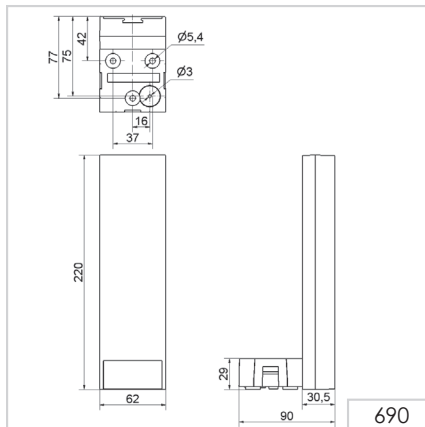



Overview Accessories for Signal Towers

Overview Accessories for Signal Towers		ClassicLOOK DesignLOOK		ClassicLOOK DesignLOOK		ClassicLOOK DesignLOOK					
Accessory	Picture	KombiSIGN 71	KombiSIGN 72	KombiSIGN 40	KOMPAKT 37	eSIGN	RST 56			Page	
Cable, 5m		●				●				82	
Bulb BA15d		●								82	
Bracket for surface mounting, incl. cable gland M16 x 1.5		●								82	
Bracket for 1-sided mounting, incl. rubber seal		●	●	●		●				82	
Bracket for 2-sided mounting, incl. rubber seal		●	●	●						82	
Bracket for tube mounting, incl. cable gland M16 x 1.5		●	●	●		●	●			86	
Bracket for base mounting, with concealed cable entry, incl. rubber seal		●	●	●	●	●	●	●	●	86	
Corner fixing bracket KOMPAKT 37 with Base-mount tube		●	●	●	●	●	●	●	●	86	
Bracket for assembly on aluminium profiles, incl. cable gland M12 x 1.5		●	●	●	●					86	
Bracket for concealed cable entry				●	●	●	●			86	
Tube Ø 25 mm plastic, for direct mounting of the terminal element onto the Foldaway Base				●	●			●		84	
Tube Ø 25 mm, all anodised aluminium		●	●	●		●	●			84	
Tube with clamp Ø 25 mm, 250 mm long, incl. cable gland		●	●	●	●	●	●	●	●	84	
Base with integrated tube Ø 25 mm, 110 mm long, plastic, incl. rubber seal		●	●	●	●	●	●	●	●	84	
Base for tube Ø 25 mm, plastic, incl. rubber seal		●	●	●	●	●	●	●	●	84	
Base for tube Ø 25 mm, metal, incl. rubber seal		●	●	●	●	●	●	●	●	84	
Base with integrated tube						●	●			88	
KombiSIGN reflect		●	●	●						82	



Overview Accessories for Signal Towers		ClassicLOOK DesignLOOK		ClassicLOOK DesignLOOK		ClassicLOOK DesignLOOK				
Accessory	Picture	KombiSIGN 71	KombiSIGN 72	KombiSIGN 40	KOMPAKT 37	eSIGN*	RST 56			Page
Cable gland for surface mounting, M16 x 1.5		●	●	●	●					84
Adaptor for single hole mounting, Ø 25 mm, M18		●	●	●						82
Adaptor for tube mounting Ø 25 mm		●	●	●						82
Indication board		●	●	●	●					82
Foldaway Base, Signal Tower can be folded away, incl. rubber seal		●	●	●	●		●		●	84
Foldaway Base, Signal Tower can be folded away, incl. rubber seal		●	●	●	●				●	84
Contact box for cable exit at side		●	●	●	●	●	●	●		86
Contact box with magnetic base and cable exit at side		●	●	●	●	●	●	●		86
Extension tube						●	●			88

* Usage of accessory dependent on version and connection cable. Please check instruction leaflet for compatibility.

Overview Accessories for Signal Towers							
Accessory	Picture	deSIGN 42	FlatSIGN	CO ₂ Traffic Light			Page
Surface housing single		●					90
Fixing kit			●				90



Overview Accessories for Signal Towers

Accessories		
	<p>Cable 5 m with M12 plug + socket Order no. 960 000 46 Cable 5 m with M12 socket Order no. 960 000 47 Cable 5 m with M12 plug Order no. 960 860 01</p>	KombiSIGN 71
	<p>Bulb BA15d, total length max. 42 mm 12 V, 5 Watt 955 840 34 24 V, 5 Watt 955 840 35 30 V, 5 Watt 955 840 32 115 V, 5 Watt 955 840 57 230 V, 5 Watt 955 840 38</p>	KombiSIGN 71
	<p>Bracket for surface mounting incl. cable gland M16 x 1.5 Order no. 960 000 02 Bracket for surface mounting incl. cable gland M16 x 1.5 Order no. 960 000 53</p>	KombiSIGN 71, 72
	<p>Adaptor for single hole mounting Ø 25 mm, M18 Order no. 960 000 25</p>	KombiSIGN 71, 72
	<p>Adaptor for single hole mounting Ø 25 mm, M18 Order no. 960 000 25</p>	KombiSIGN 71, 72
	<p>Bracket for 1-sided mounting, incl. rubber seals Order no. 975 840 85 Bracket for 1-sided mounting, incl. rubber seals Order no. 960 000 52</p>	KombiSIGN 71, 72
	<p>Bracket for 2-sided mounting, incl. rubber seals Order no. 975 840 86</p>	KombiSIGN 71, 72
	<p>KombiSIGN reflect Order no. 861 640 01  Order no. 861 640 02  </p>	KombiSIGN 71, 72
	<p>Indication board (for tube mounting) Order no. 960 000 05 Dimensions of indication board (W x H): 153 x 345 mm Surface area per section (W x H): c. 144 x 54 mm Avery/Zweckform 3424 (105 x 48 mm), Herma 4281 (105 x 50.8 mm) (not included in assembly) Material: PMMA <ul style="list-style-type: none"> • For one to five modules • Simple mounting onto signal tower tube • Ample space for written information • Simply break off unwanted segments </p>	KombiSIGN 71, 72



← TECHNICAL DIAGRAMS:

<p>960.000.02 960.000.53</p>	<p>960.000.25</p>	<p>975.840.02</p>
<p>975.840.85 960.000.52</p>	<p>975.840.86</p>	<p>KombiSIGN reflect master KombiSIGN reflect slave 861.640.OX</p>
<p>960.000.05</p>		



Overview Accessories for Signal Towers

Accessories		
	Tube with clamp, Ø 25 mm, 250 mm long, incl. cable gland Order no. 960 000 18	KombiSIGN 71, 72, 40 eSIGN RST 56
	Base with integrated tube, Ø 25 mm, 110 mm long, plastic, incl. rubber seal Order no. 975 840 10 Base with integrated tube, Ø 25 mm, 110 mm long, plastic, incl. rubber seal Order no. 960 000 51	KombiSIGN 71, 72, 40 RST 56
	Tube Ø 25 mm, all anodised aluminium 100 mm long 975 845 10 250 mm long 975 840 25 400 mm long 975 840 40 600 mm long 975 840 60 800 mm long 975 840 80 1000 mm long 975 840 03	KombiSIGN 71, 72, 40 eSIGN RST 56
	Base for tube mounting, Ø 25 mm, plastic, incl. rubber seal Order no. 975 840 90* Base for tube mounting, Ø 25 mm, plastic, incl. rubber seal Order no. 960 000 50	KombiSIGN 71, 72, 40 *eSIGN RST 56 *IP66/69k (see instructions)
	Base for tube Ø 25 mm, metal, incl. rubber seal, recommended for tube lengths of 400 mm and longer Order no. 975 840 91	KombiSIGN 71, 72, 40 eSIGN RST 56
	Cable gland for surface mounting, M16 x 1.5 Order no. 960 000 04	KombiSIGN 71, 72, 40
	Tube Ø 25 mm, plastic, 45 mm long, for direct mounting on foldaway base (only for KombiSIGN 71 and 72) Order no. 960 000 31	KombiSIGN 71, 72, 40 RST 56
	Foldaway Base - Signal Tower can be folded away, including rubber seal, for tube (all anodised aluminium) Ø 25 mm (not included in assembly) Order no. 960 000 30 Dimensions (Ø x Height) 70 mm x 117 mm Material: PA-GF Cable diameter: Max. 14 mm Fixing: Vertical, horizontal, Positioning in 7.5° steps	KombiSIGN 71, 72, 40 RST 56
	Foldaway Base - Signal Tower can be folded away, including rubber seal, for tube (all anodised aluminium) Ø 25 mm (not included in assembly) Order no. 960 009 12 Dimensions (Ø x Height) 70 mm x 85 mm Material: PA-GF Cable diameter: Max. 8 mm Fixing: Vertical, horizontal, Positioning in 0° and 90°	KombiSIGN 71, 72, 40 RST 56

↔ TECHNICAL DIAGRAMS:

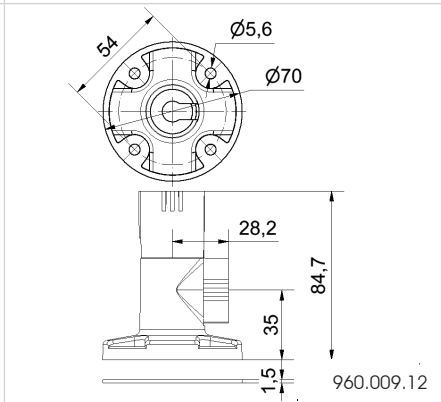
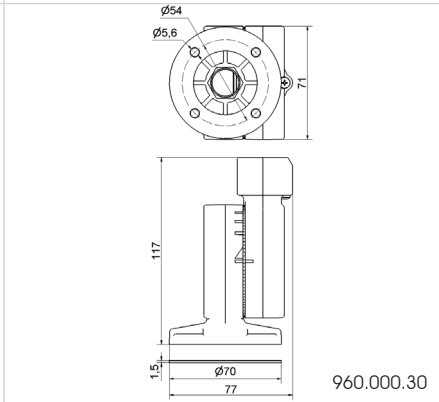
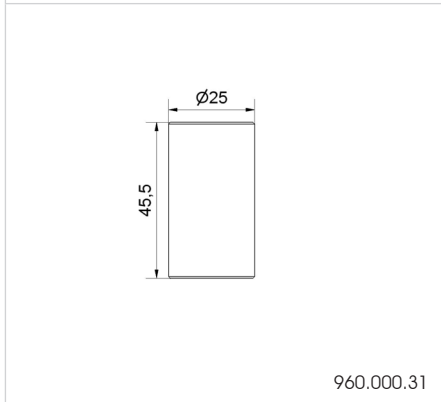
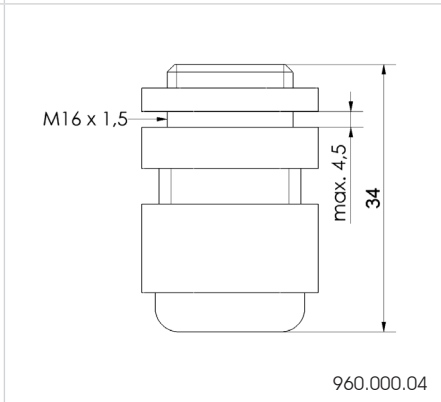
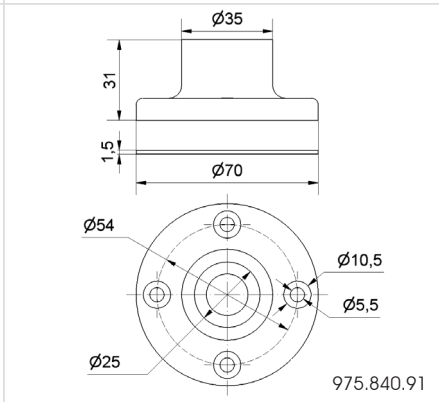
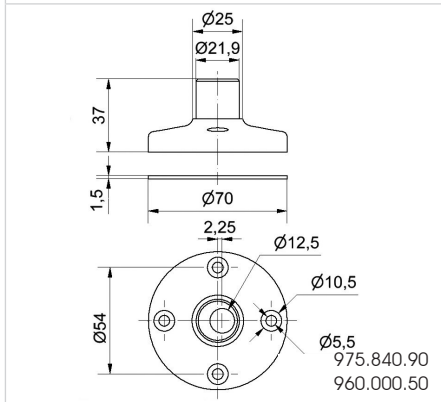
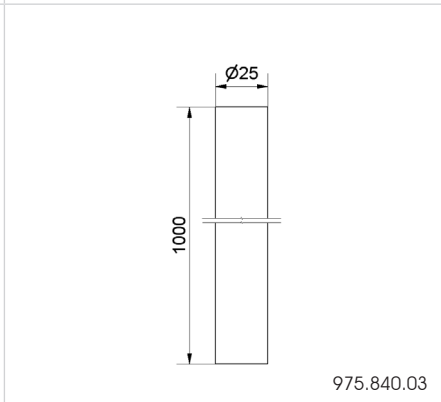
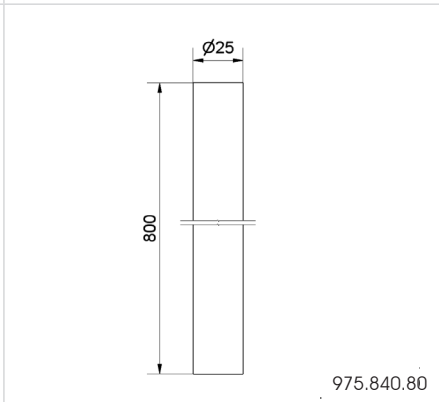
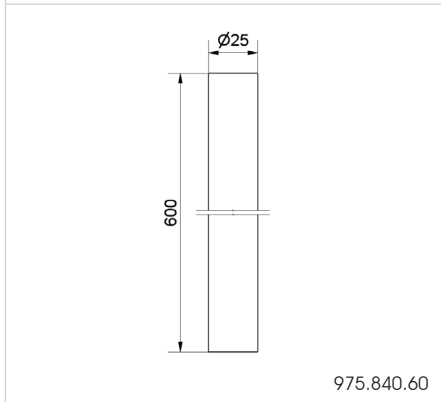
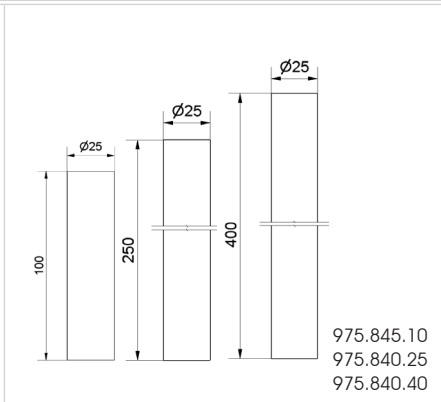
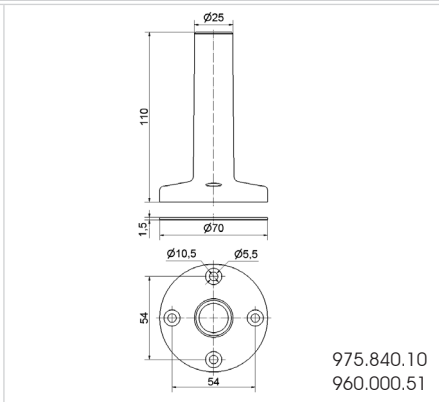
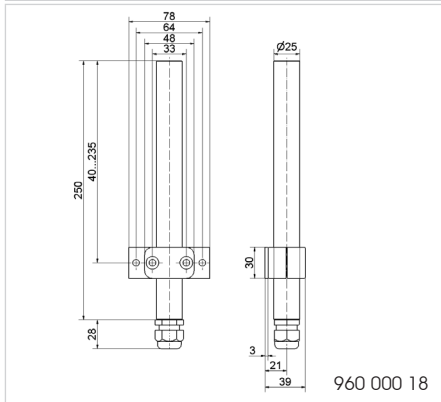



Overview Accessories for Signal Towers

Accessories		Zubehör kompatibel mit
	<p>Bracket for tube mounting, incl. cable gland M16 x 1.5 Order no. 960 000 01</p> <p>Bracket for tube mounting, incl. cable gland M16 x 1.5 Order no. 960 000 54</p>	<p>KombiSIGN 71, 72, 40 KOMPAKT 37 eSIGN RST 56</p>
	<p>Bracket for base mounting, with concealed cable entry, incl. rubber seals Order no. 960 000 14</p> <p>Bracket for base mounting, with concealed cable entry, incl. rubber seals Order no. 960 000 55</p>	<p>KombiSIGN 71, 72, 40 KOMPAKT 37 RST 56</p>
	<p>Corner fixing bracket (KOMPAKT 37 with Base-mount tube) Order no. 960 000 41</p>	<p>KombiSIGN 71, 72, 40 KOMPAKT 37 eSIGN RST 56</p>
	<p>Contact box for cable exit at side, with mounting material and seal, cable gland M16 x 1.5 Order no. 975 840 01</p>	<p>KombiSIGN 71, 72, 40 KOMPAKT 37</p>
	<p>Contact box with magnetic base and cable exit at side cable gland M16 x 1.5 Order no. 975 840 04</p>	<p>KombiSIGN 71, 72, 40 KOMPAKT 37</p>
	<p>Bracket for assembly on aluminium profiles incl. cable gland M12 x 1.5 Order no. 960 630 02</p> <p>Bracket for assembly on aluminium profiles incl. cable gland M12 x 1.5 Order no. 960 630 06</p>	<p>KombiSIGN 40</p>
	<p>Bracket for concealed cable entry Order no. 960 630 01</p> <p>Bracket for concealed cable entry Order no. 960 630 05</p>	<p>KombiSIGN 40</p>
	<p>Indication board (base/wall mounting) Order no. 960 630 08</p> <p>Indication board (tube mounting) Order no. 960 630 09</p>	<p>KombiSIGN 40</p>
	<p>USB cable type C to type A 3 m Order no. 960 000 71</p>	<p>KombiSIGN 40</p>

← TECHNICAL DIAGRAMS:

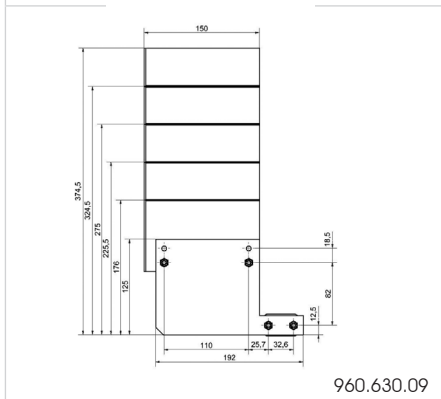
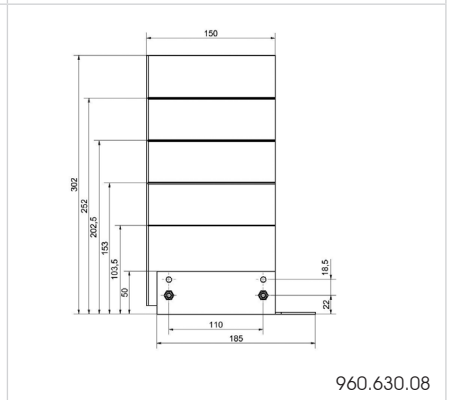
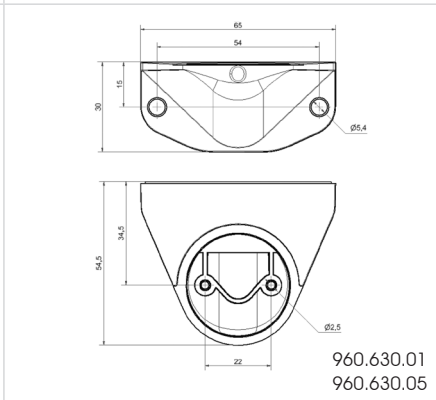
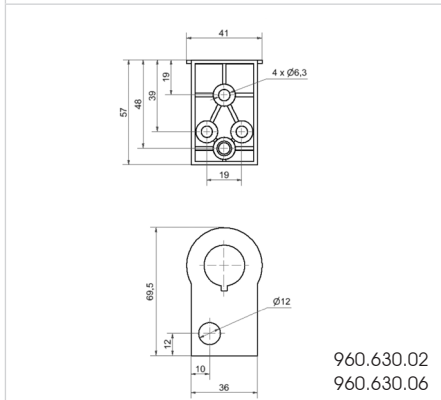
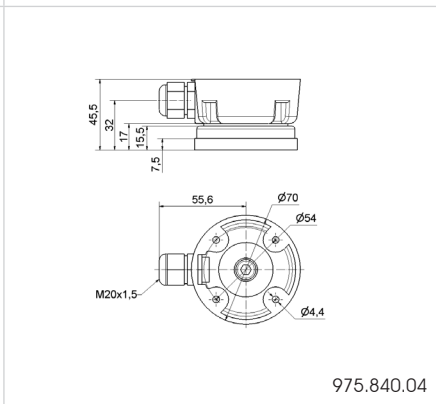
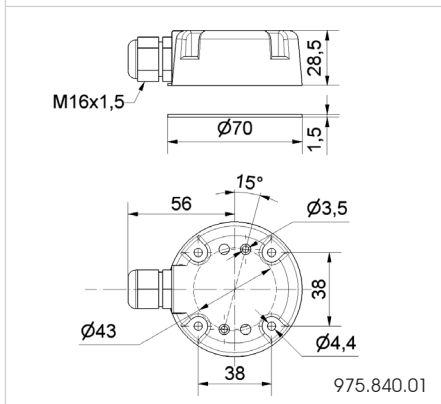
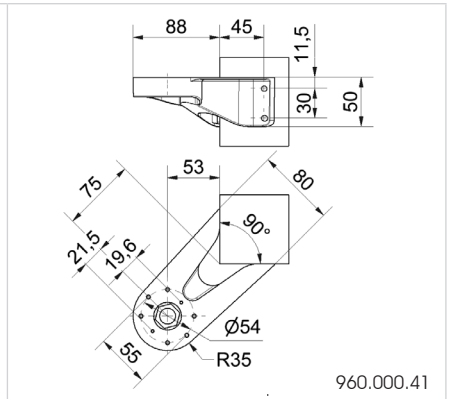
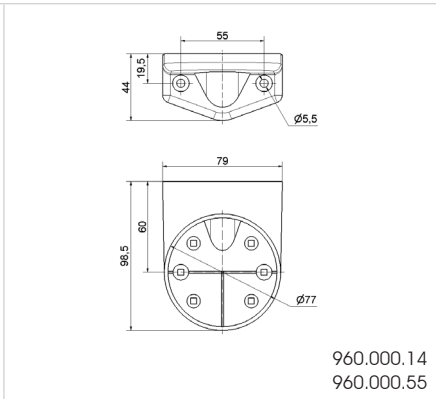
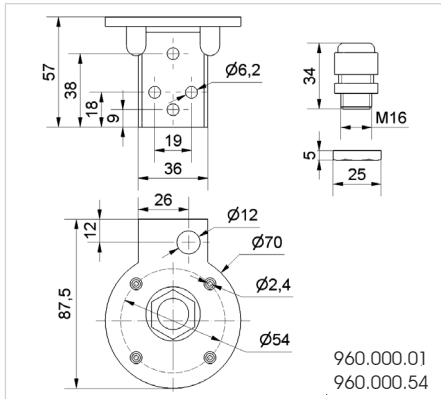



Overview Accessories for Signal Towers

Accessories		
	Extension tube Order no. 960 698 02 Extension tube Order no. 960 698 04	KOMPAKT 37
	Base with integrated tube Order no. 960 698 01 Base with integrated tube Order no. 960 698 03	KOMPAKT 37
	Bracket for base mounting Order no. 960 698 05	KOMPAKT 37
	Cable 5 m with M12 connector and plug Order no. 960 000 46** Cable 5 m with M12 plug Order no. 960 000 47** USB cable type C to type A 0.5 m Order no. 960 000 69** USB cable type C to type A 1.8 m Order no. 960 000 70**	eSIGN
	Bracket for 1-sided mounting Order no. 960 000 65*	eSIGN
	Base with integrated tube, Ø 25 mm, 110 mm long, plastic, incl. rubber seal Order no. 960 000 64*	eSIGN

* = UL Type 4X and IP 66/69K (see instructions for exact details)

** = Standard 24 V

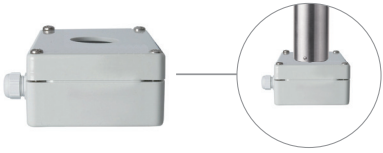
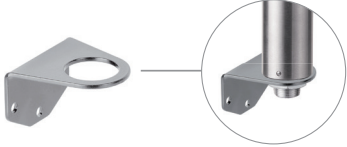
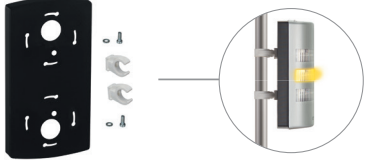

Overview Accessories for Signal Towers

Accessories		
	Surface housing single Order no. 975 109 02	deSIGN 42
	Bracket, stainless steel (Protection rating IP33) Order no. 960 694 01	deSIGN 42
	Fixing kit Order no. 975 691 01	FlatSIGN

← TECHNICAL DIAGRAMS:

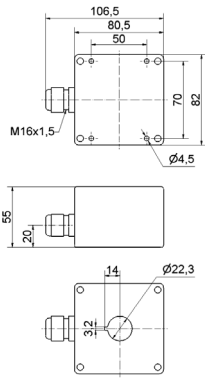

975.109.02

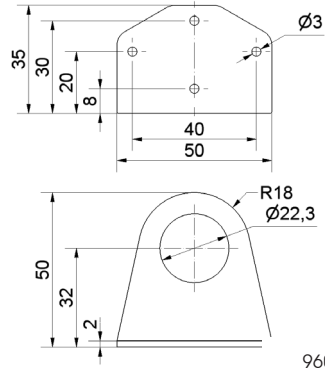

960.694.01

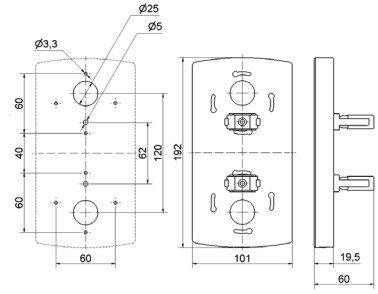

975.691.01







Beacons & Traffic Lights

Overview Beacons & Traffic Lights

WERMA's beacons and traffic lights help you indicate risks and imminent danger promptly and clearly. The urgency of the required action can be indicated by the colour of the light and by the type and duration of the signal.

This allows you to make your processes safe and efficient. Simply safe. Simply better. This is what we call intelligent signal technology.



Overview Signal Beacons & Traffic Lights		Installation			Surface mounting			
Technical specification	Variant	Micro	Frosted	Mini	Mini	Midi	Maxi	Monitorable Beacon
		23X	240, 241, 239 ASi	80X, 816, 81X, USB, EvoSIGNAL	EvoSIGNAL	EvoSIGNAL	EvoSIGNAL	806, 829
Dimensions (Ø x Height)*	See technical specifications							
Voltage	12 V	●		●	●	●	●	
	24 V	●	●	●	●	●	●	●
	48 V							
	115 V	●		●	●	●	●	
	230 V	●		●	●	●	●	
Optical	LED Permanent Light	●	●	●				●
	LED Blinking Light		●	●				
	LED Permanent Light (multicolour)			●	TriCOLOUR	TriCOLOUR		
	TwinLIGHT (Permanent/Blinking)			●	●	●	●	
	TwinFLASH (Flash/EVS)			●	●	●	●	
	LED Flashing Light			●				
	LED EVS Light							
	Permanent Light							●
	LED Rotating					●	●	
Rotating Mirror/Rotating Light					●	●		
Protection Rating		IP65	IP65	IP65	IP66	IP66	IP66	IP65
Page		Page 99	Page 102	Page 106	Page 112	Page 115	Page 118	Page 121

* Technical diagrams can be found on the product page

Installation beacons

Installation beacons are used for installation in M20/M22 drilled holes. The beacon is fixed from the back, in control panels for example, using a locking nut. This prevents subsequent tampering.

Surface mounted beacons

Surface mounted beacons are fixed directly onto the surface of the relevant object (machines). The basic mounting options are base, bracket or tube installation.

							
Rotating beacon			Obstruction Lights	Heavy Duty	Traffic Lights		
LED-Rotating Mirror Beacon	LED-Rotating Beacon Fresnel	LED-Rotating	Low Intensity Type A and B				
883, 885	884	EvoSIGNAL Midi + Maxi	280, 281	839	FlexSQUARE, 890, 895, 897, 894		
See technical specifications							
		•	•	•	•	•	
•	•	•	•	•	•	•	•
			•		•		
•	•	•		•	•	•	•
•	•	•	•	•	•	•	•
			•	•	•	•	•
		TriCOLOUR (Midi)			•	•	
		•					
		•					
					•		
					•		
	•	•		•			•
•	•	•					
IP65	IP65	IP66	IP65 / IP66/68	IP67	IP67	IP65/IP69k	IP65/IP69k
Page 125	Page 17	Page 128 + 129	Page 130	Page 133	Page 136	Page 142	Page 150



Sizes

Comparison of WERMA beacons and traffic lights



Series	230	240	241	EvoSIGNAL Mini
Thread	M20	M30	M22	M22
Ø	29 mm	55 mm	35 mm	62 mm
Height (Protrusion from panel)	32 mm	46 mm	64 mm	85 mm



Series	EvoSIGNAL Mini	EvoSIGNAL Midi	EvoSIGNAL Maxi
Ø	62 mm	85 mm	120 mm
Height	85 mm	130 mm	173 mm

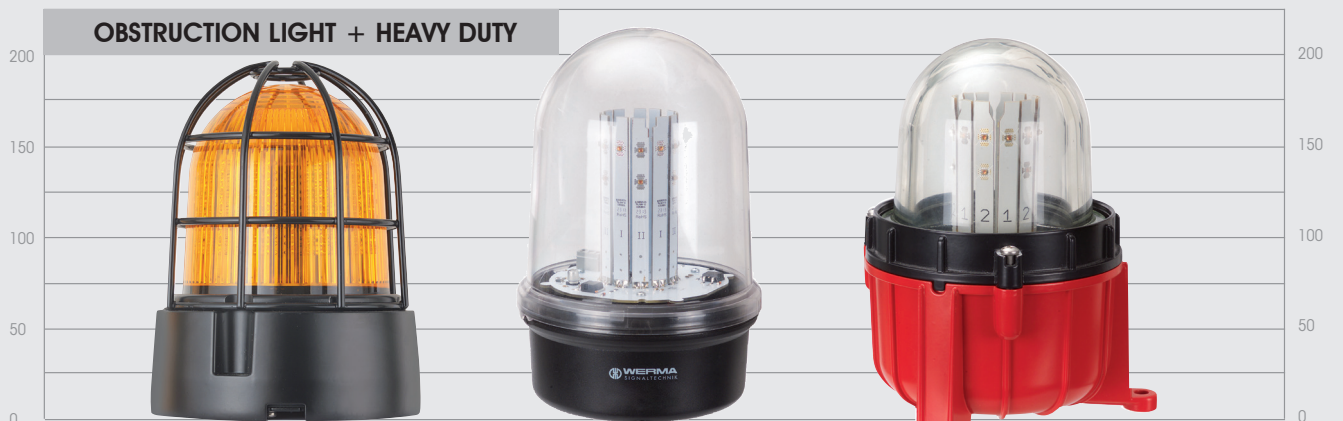

Series	839	280	281
Ø	153 mm	142 mm	165 mm
Height	189 mm	218 mm	205 mm



Series	EvoSIGNAL Midi	EvoSIGNAL Maxi	883/884	885
Ø	85 mm	120 mm	142 mm	98 mm
Height	130 mm	173 mm	218 mm	151 mm

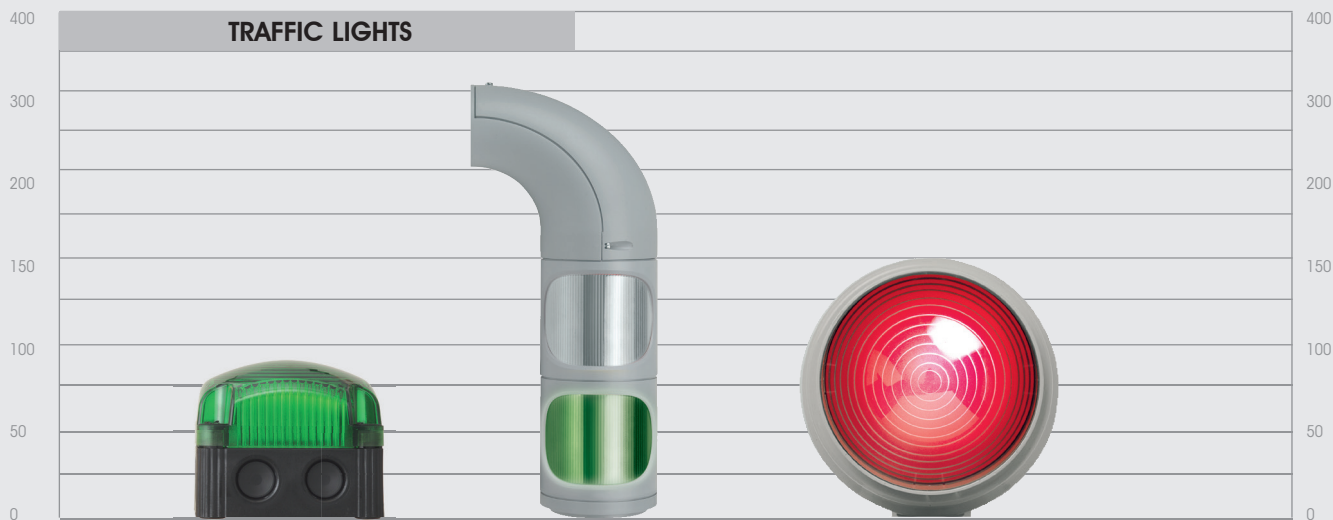

Series	853	894	890
Ø	85 mm	98 mm	150 mm
Height	85 mm	309 mm	154 mm

Micro Installation Beacons - 23x

Your benefits

Despite their size, micro installation beacons from the 230 / 231 / 232 range will provide good all-round visibility. The range includes control panel indicator lights.

- The industry standard for control panels
- Easy to install, even where space is restricted

Typical applications

Signalling faults and statuses

- On small machines and equipment
- In building technology

Installation options

- M22 single-hole mounting including nut
- M20 for direct installation, in safety switches, for example

Features

- Available with a permanent light



Size comparison
Micro/Mini/EvoSIGNAL Mini

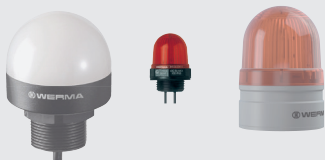

230 LED Installation Beacon



Mainly sideways illumination



The LED Installation Beacon 230 can for example be used in applications with cable-operated switches or limit switch devices

① TECHNICAL SPECIFICATIONS/ORDER SPECIFICATIONS:

Dimensions (Ø x Height):	29 mm x 32 mm (Protrusion from panel)			
Housing:	PC/ABS-Blend			
Lens:	PC, transparent			
Connection:	2 wires, c. 115 mm long			
Fixing:	Installation mounting for Ø 20.5 mm (M20 x 1.5 mm)			
Life duration:	Up to 100,000 hrs			
Seal included in assembly.				
Voltage:	12 V DC	24 V DC	115 V AC	230 V AC
Current consumption:	80 mA	45 mA	15 mA	20 mA
red	230 100 54	230 100 55	230 100 67	230 100 68
yellow	230 300 54	230 300 55	230 300 67	230 300 68
clear	-	230 400 55	-	-
Further colours on request.				

← TECHNICAL DIAGRAM:

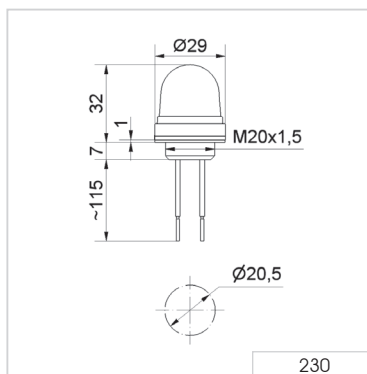

24 V





231 LED Installation Beacon



Mainly sideways illumination

① TECHNICAL SPECIFICATIONS/ORDER SPECIFICATIONS:

Dimensions (Ø x Height):	29 mm x 32 mm (Protrusion from panel)			
Housing:	PC/ABS-Blend			
Lens:	PC, transparent			
Connection:	2 wires, c. 105 mm long			
Fixing:	Installation mounting for Ø 22.5 mm (M22 x 1.5 mm)			
Life duration:	Up to 100,000 hrs			
Nut and seal included in assembly.				
Voltage:	12 V DC	24 V DC	115 V AC	230 V AC
Current consumption:	80 mA	45 mA	15 mA	20 mA
red	231 100 54	231 100 55	231 100 67	231 100 68
green	231 200 54	231 200 55	231 200 67	231 200 68
yellow	231 300 54	231 300 55	231 300 67	231 300 68
clear	231 400 54	231 400 55	231 400 67	231 400 68
blue	231 500 54	231 500 55	231 500 67	231 500 68

↔ TECHNICAL DIAGRAM:

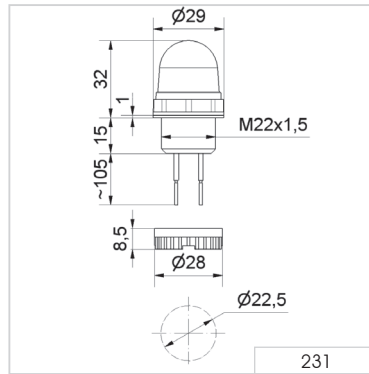

24 V



Mini Installation Beacons - 239/24x

Your benefits

WERMA's mini installation beacons are perfect for use on machinery and control panels. The colours can be set quite simply by means of binary inputs.

- Up to seven different colours with just one light
- Low lens, where space is restricted
- Raised lens for best visibility also from the side

Typical applications

Signalling faults and statuses

- On control consoles of machinery
- In machine housings
- On control panels

Installation options

- M22 single-hole mounting (239,241)
- M30 single-hole mounting (240)

Features

- Bit-encoded actuation allows the three basic colours green, yellow and red to be displayed using just two PLC outputs. With a third output, white and blue can also be activated.
- With Spec. V 3.0, the special AS interface version is suitable for addressing (A/B mode) up to 62 modules – without an external power supply (239)

Touch variants (MC55):

- Reporting and acknowledging an alarm when the machine is at a standstill and reporting back when the error is fixed
- Reporting a problem/error using a touch button
- Starting and stopping a machine using a touch button
- Switching a device by pressing and holding or pressing the touch button
- Escalation if an error condition persists for too long



239 LED Installation Beacon (Multicolour) for AS-Interface



Five colours in one beacon:
red, yellow, green, white and blue



① TECHNICAL SPECIFICATIONS/ORDER SPECIFICATIONS:

Dimensions (Ø x Height):	50 mm x 22 mm (Protrusion from panel)
Housing:	PC/ABS-Blend, black
Lens:	PC, transparent
Fixing:	Installation mounting for Ø 22.5 mm (M22 x 1.5 mm) with anti-twist device
Connection:	Screw terminal with wire protection max. 1.5 mm ²
Power supply AS-Interface:	Via bus conduction
Operating voltage:	25 V ... 31.6 V according to the AS-Interface specification
Current consumption:	≤ 100 mA
Specification:	V3.0
IO-Code:	8 _{HEX}
ID-Code:	A _{HEX}
ID2-Code:	E _{HEX}
Colour options:	Red, yellow, green, white, blue
Life duration:	Up to 50,000 hrs
Nut and seal included in assembly.	
LED Installation Beacon (multicolour) for AS-Interface	239 780 55

↔ TECHNICAL DIAGRAM:

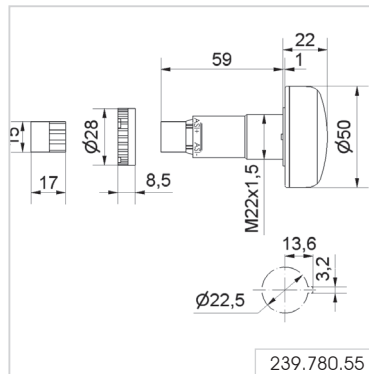

Approval No. 2001



241 LED Installation Beacon (Multicolour/MC35) with UL



① TECHNICAL SPECIFICATIONS/ORDER SPECIFICATIONS

Dimensions (Ø x Height)	35 mm x 64 mm (Protrusion from panel)		
Housing	PC/ABS-Blend, black		
Lens	PC, transparent		
Fixing	Installation mounting M22		
Connection	M12 5 PIN		
Colour options	Red, yellow, green, white, blue, violet, turquoise (Multicolour) Red, yellow, green (Tricolour)		
Light effects	Permanent light		
Life duration light	Up to 50,000 hrs		
Life duration buzzer	Up to 5,000 hrs		
	Voltage	Current consumption	Plug M12
Tricolour (RGY)	24 V DC	20 mA	241 420 55
Multicolour (RGB)	10-30 V DC	30 mA	241 320 50

MC35 High IO-Link

Connection	M12 4 PIN
Colour options	Multicolour LED, configurable colours > 1 million colours
Light effects	Permanent, blinking, flashing and pulse light
Voltage	18-30 V DC
Current consumption	25 mA
Order no.	241 510 00

↔ TECHNICAL DIAGRAM

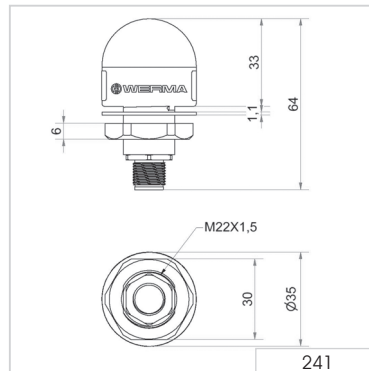

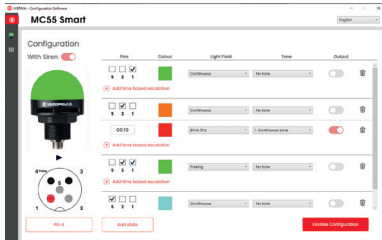

Configuration software for the Smart version



240 LED Installation Beacon (Multicolour/MC55) with or without UL

① TECHNICAL SPECIFICATIONS/ORDER SPECIFICATIONS

Dimensions (Ø x Height)	55 mm x 46 mm (Protrusion from panel)
Housing	PC/ABS-Blend, black PC black (UL version)
Lens	PC, transparent
Fixing	Installation mounting M30
Life duration light	Up to 50,000 hrs

① MC55 STANDARD

Colour options	Red, yellow, green, white, blue, violet, turquoise (Multicolour) Red, yellow, green (Tricolour)			
Light effects	Permanent light, permanent and blinking light (1 Hz) (240 110 50)			
Without UL	Voltage	Current consumption	Plug M12	Cable
Tricolour (RGY)	24 V DC	45 mA	240 220 55	240 210 55
Multicolour (RGB)	10-30 V DC	60 mA	240 120 50	240 110 50
With UL				
Tricolour (RGY)	24 V DC	40 mA	240 420 55	-
Multicolour (RGB)	10-30 V DC	100 mA	240 320 50	-

① MC55 SMART

Connection	M12 5 PIN
Colour options	Multicolour LED, configurable colours > 1 million colours
Light effects	Permanent, blinking, flashing and pulse light
Voltage	24 V DC
Current consumption	max. 130 mA
Order no.	240 520 00

① MC55 IO-LINK

Connection	M12 4 PIN
Colour options	Multicolour LED, configurable colours > 1 million colours
Light effects	Permanent, blinking, flashing and pulse light
Voltage	18-30 V DC
Current consumption	55 mA
Order no.	240 510 00

↔ TECHNICAL DIAGRAM

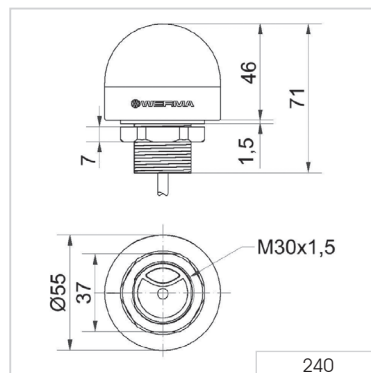

240.520.00
240.420.55
240.320.50
240.510.00



240 LED Installation Beacon (Multicolour/MC55 Touch)



① TECHNICAL SPECIFICATIONS/ORDER SPECIFICATIONS

Dimensions (Ø x Height):	55 mm x 44 mm (Protrusion from panel)			
Housing:	PC, black			
Lens:	PC, transparent			
Fixing:	Installation mounting M30			
Connection:	M12 5 PIN			
Colour options:	Red, yellow, green (Tricolour)			
Light effects:	Permanent light			
Life duration light:	Up to 50,000 hrs			
Ausgangsstrom	max. 200 mA			
Ausgang	Puls-Feedback			
	Voltage	Current consumption	NPN	PNP
Tricolour (RGY)	24 V DC	50 mA	240 260 55	240 280 55

240 LED Installation Beacon (Multicolour/MC55 Touch Smart)



Configuration software for the Smart version

① TECHNICAL SPECIFICATIONS/ORDER SPECIFICATIONS

Dimensions (Ø x Height):	55 mm x 44 mm (Protrusion from panel)			
Housing:	PC, black			
Lens:	PC, transparent			
Fixing:	Installation mounting M30			
Connection:	M12 5 PIN			
Colour options:	Multicolour LED, configurable colours > 1 million colours			
Light effects:	Permanent, Blinking, Flashing and Pulse light			
Life duration light:	Up to 50,000 hrs			
Voltage	24 V DC			
Current consumption	60 mA			
Order no.	240 160 55			

↔ TECHNICAL DIAGRAM

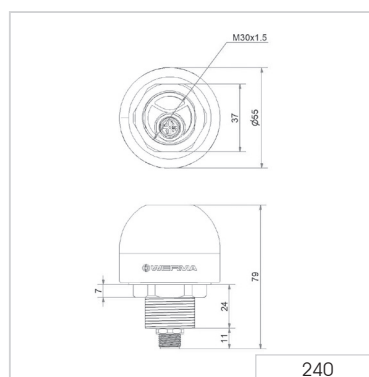



240 LED Installation Beacon (Multicolour/MC55 Touch IO-Link)

TECHNICAL SPECIFICATIONS/ORDER SPECIFICATIONS

Dimensions (Ø x Height)	55 mm x 44 mm (Protrusion from panel)
Housing	PC black
Lens	PC, transparent
Fixing	Einbaumontage M30
Connection	M12 4 PIN
Colour options	Multicolour LED, configurable colours > 1 million colours
Light effects	Permanent, blinking, flashing and pulse light
Life duration light	Up to 50,000 hrs
Voltage	18-30 V DC
Current consumption	55 mA
Order no.	240 510 02

TECHNICAL DIAGRAM

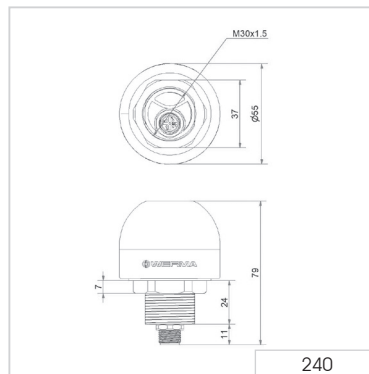

240 LED Beacon Multicolour MC55 High Tube and base mounting



① TECHNICAL SPECIFICATIONS/ORDER SPECIFICATIONS

Dimensions (Ø x Height)	55 mm x 111 mm
Housing	PC black
Lens	PC, transparent
Fixing	Installation mounting M30
Connection	M12 5 PIN (IO-Link: M12 4 PIN)
Life duration light	Up to 50,000 hrs

MC55 High

Colour options	Red, yellow, green, white, blue, violet, turquoise (Multicolour) Red, yellow, green (Tricolour)		
Light effects	Permanent light		
	Voltage	Current consumption	
Tricolour (RGY)	24 V DC	42 mA	240 600 03
Multicolour (RGB)	10-30 V DC	max. 130 mA	240 600 01

MC55 High Smart

Colour options	Multicolour LED, configurable colours > 1 million colours
Light effects	Permanent, blinking, flashing and pulse light
Voltage	24 V DC
Current consumption	max. 130 mA
Order no.	240 620 00

MC55 High IO-Link

Colour options	Multicolour LED, configurable colours > 1 million colours
Light effects	Permanent, blinking, flashing and pulse light
Voltage	18-30 V DC
Current consumption	55 mA
Order no.	240 610 00



↔ MASSZEICHNUNG

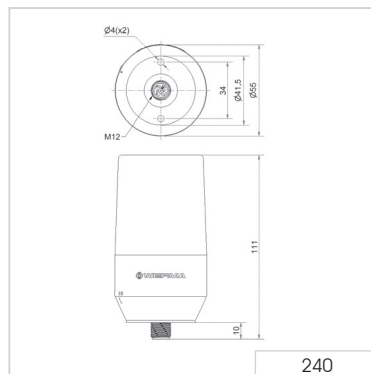

Mini Beacons - 800/801/816 families + EvoSIGNAL

Your benefits

The Mini Signal Beacons are used wherever space is restricted.

The beacons are easy to install and connect, even in tight spaces, thanks to convenient connection terminals and easily accessible mounting holes.

- Reliable signalling at close quarters
- Available as a permanent light or as a bright Xenon flash light to attract attention
- Robust and tamper-proof

Typical applications

Signalling of faults

- On small machines and equipment
- In building technology

Installation options

- Base mounting
- M22/PG29 single-hole mounting
- Bracket mounting
- Tube mounting

Features

- High protection rating IP65 for both indoor and outdoor use

The 816 :

- Robust and shock-resistant up to 20 joules



Size comparison Mini 239/Mini



260 LED Installation Beacon EvoSIGNAL Mini



① TECHNICAL SPECIFICATIONS/ORDER SPECIFICATIONS:

Dimensions (Ø x Height):	62 mm x 85 mm
Housing:	PC-ABS, grey, high impact
Lens:	PC, transparent
Fixing:	Installation mounting
Cable entry:	Cable diameter 8-12 mm
Connection:	Push-In terminal max. 1.5 mm ²
Flash/Blink frequency:	1 Hz

TwinLIGHT (Permanent/Blinking)

Voltage:	12 V AC/DC	24 V AC/DC	115-230 V AC
Current consumption:	≤ 90 mA	≤ 75 mA	≤ 45 mA
red	260 110 74	260 110 75	260 110 60
green	260 210 74	260 210 75	260 210 60
yellow	260 310 74	260 310 75	260 310 60
white	260 410 74	260 410 75	260 410 60
blue	260 510 74	260 510 75	260 510 60

TwinFLASH (Flash/EVS)

Voltage:	12 V AC/DC	24 V AC/DC	115-230 V AC
Current consumption:	≤ 70 mA	≤ 75 mA	≤ 45 mA
red	260 120 74	260 120 75	260 120 60
green	260 220 74	260 220 75	260 220 60
yellow	260 320 74	260 320 75	260 320 60
white	260 420 74	260 420 75	260 420 60
blue	260 520 74	260 520 75	260 520 60

TriCOLOUR

Voltage:		24 V AC/DC	
Current consumption:		≤ 90 mA	
Order no.		260 430 75	

✂ ACCESSORIES:

Installation mounting M22	260 700 03
Installation mounting PG 29	260 700 04

↔ TECHNICAL DIAGRAM:

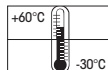
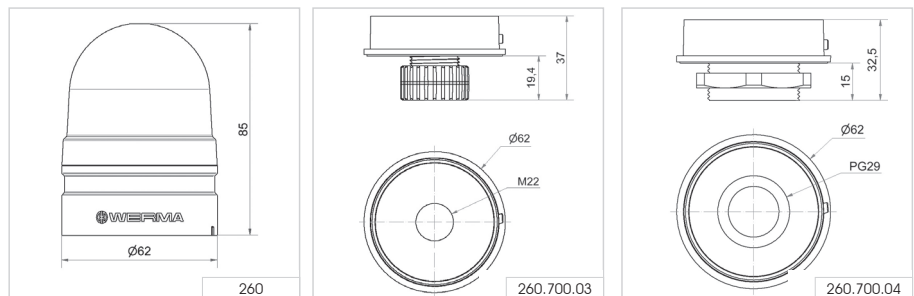

800 Installation Permanent Beacon - PG29 (Ø 37 mm)



Bulb change via rear access with bayonet holder



Accessories

① TECHNICAL SPECIFICATIONS/ORDER SPECIFICATIONS:

Dimensions (Ø x Height):	57 mm x 54 mm (Protrusion from panel)
Housing:	PC/ABS-Blend Socket: PA-GF, high impact
Lens:	PC, transparent
Connection:	Screw terminal 0.5 -1.5 mm ²
Fixing:	Installation mounting for Ø 37 mm (PG29)
Operating voltage:	12-230 V
Bulb socket:	BA15d, 5 Watt max.
Bulb change:	Via rear access with bayonet mechanism
Bulb not included in assembly.	
Voltage:	12-230 V
red	800 100 00
green	800 200 00
yellow	800 300 00
white	800 400 00
blue	800 500 00

✂ ACCESSORIES:

Bulb BA15d, 5 W total length 42 mm

Voltage:	12 V AC/DC	24 V AC/DC	30 V AC/DC	115 V AC/DC	230 V AC/DC
	955 840 34	955 840 35	955 840 32	955 840 57	955 840 38
Tube adaptor	975 812 01				
Base with integrated tube, Ø 25 mm, 110 mm long, plastic	975 840 10				
Base for tube mounting	975 840 90				
Base for base mounting	975 812 02				
Tube Ø 25 mm, all anodised aluminium					
100 mm long	975 845 10				
250 mm long	975 840 25				
400 mm long	975 840 40				
Anti-twist device	975 815 22				
Surface housing IP 65					
for 1 Installation Beacon	975 815 03				
for 2 Installation Beacons	975 815 07				
for 3 Installation Beacons	975 815 08				
for 4 Installation Beacons	975 109 05				

↔ TECHNICAL DIAGRAM:

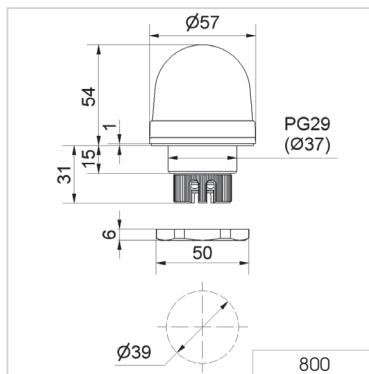

801 LED Installation Permanent Beacon - PG29 (Ø 37 mm)



Tube adaptor as accessory



Accessories

① TECHNICAL SPECIFICATIONS/ORDER SPECIFICATIONS:

Dimensions (Ø x Height):	57 mm x 54 mm (Protrusion from panel)		
Housing:	PC/ABS-Blend Socket: PA-GF, high impact		
Lens:	PC, transparent		
Fixing:	Installation mounting for Ø 37 mm (PG29)		
Connection:	Screw terminal 0.5 - 1.5 mm ²		
Life duration:	Up to 100,000 hrs		
Voltage:	24 V AC/DC	115 V AC	230 V AC
Current consumption:	45 mA	25 mA	25 mA
red	801 100 75	801 100 67	801 100 68
green	801 200 75	801 200 67	801 200 68
yellow	801 300 75	801 300 67	801 300 68

Further colours and voltages on request.

✂ ACCESSORIES:

Tube adaptor	975 812 01
Base with integrated tube, Ø 25 mm, 110 mm long, plastic	975 840 10
Base for tube mounting	975 840 90
Base for base mounting	975 812 02
Tube Ø 25 mm, all anodised aluminium	
100 mm long	975 845 10
250 mm long	975 840 25
400 mm long	975 840 40
Anti-twist device	975 815 22
Surface housing IP 65	
for 1 Installation Beacon	975 815 03
for 2 Installation Beacons	975 815 07
for 3 Installation Beacons	975 815 08
for 4 Installation Beacons	975 109 05

← TECHNICAL DIAGRAM:

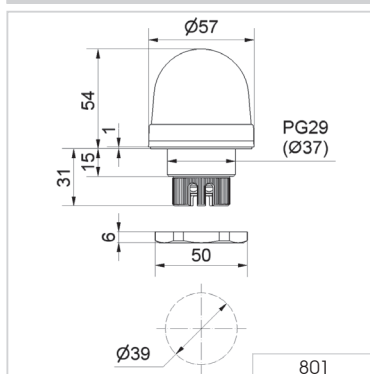

816 LED Beacon (Multicolour) with USB Interface - PG29 (Ø 37 mm)

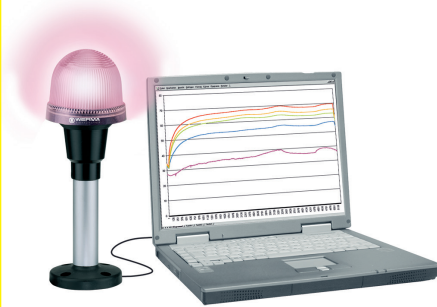

Simple triggering as no special software is required

① TECHNICAL SPECIFICATIONS/ORDER SPECIFICATIONS:

Dimensions (Ø x Height):	75 mm x 66 mm (Protrusion from panel)
Housing:	ABS/PC-Blend, black
Lens:	PC, transparent Shock resistance 20 Joules according to EN 60079-0
Fixing:	Installation mounting for Ø 37 mm (PG29) Base and wall mounting possible (accessories)
Connection:	Mini USB 2.0 downward cable outlet
Power supply:	Via USB
Colour options:	More than 200,000 colours (RGB LED)
Suitable for:	Windows®, System requirements – see Handbook
Assembly:	LED beacon, demo software, driver and USB connection cable included, 1.8 m long
Life duration:	Up to 50,000 hrs
Voltage:	5 V (USB-Connection)
Current consumption:	≤ 500 mA
clear lens	816 480 53

✂ ACCESSORIES:

You will find the appropriate accessories for base or tube mounting on page 104 or under www.werma.com

! ADDITIONAL INFORMATION:

The installation LED Beacon with USB interface is compatible with USB 2.0 and 1.1. A wide range of colours and light effects can be quickly and simply programmed by the customer and altered at any time.

↳ TECHNICAL DIAGRAM:

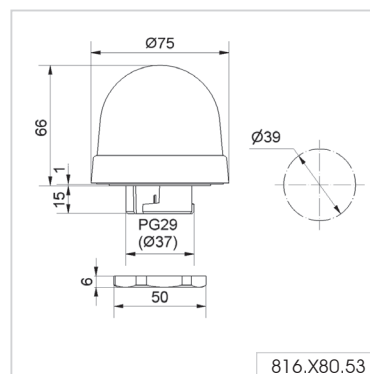

Evo*SIGNAL* - LED Signal Beacon Mini, Midi, Maxi

Your benefits

The type of optical signals used depends on the application and the surroundings. With Evo*SIGNAL*, finding the right signal device has never been so easy: Almost all areas of application are optimally covered by only three sizes (signal lamps) with specific mounting adapters. The new modular, simple and clear standard solution. Evo*SIGNAL* is one of a kind.

- Simple and easy to use: Number of different articles reduced to 20% whilst retaining a full range
- Twin functions: Twin*LIGHT* and Twin*FLASH* unite two light pattern functions in one element. They can be remote-controlled via connection terminals and also used as escalation levels
- Poka Yoke: Simple and intuitive installation - incorrect installation is impossible
- Mini and Midi also available as Tri*COLOUR* variants
- Maxi Twin*FLASH* can be used as an attention-grabbing alternative to xenon strobes and rotating mirror beacons

Typical applications

Signal faults and statuses on machines and equipment, in building services engineering and in door and gate applications. All products are ideal for demanding indoor and outdoor applications.

- Mini – on installations with limited space
- Midi – signalling over medium distances (10–30 m)
- Maxi – signalling over long distances (> 20 m)

Installation options

- Base mounting
- M22/PG29 single-hole mounting
- Tube mounting
- Bracket mounting

Features

- Push-in connection terminals: Simple and permanently secure connection
- Fully compatible: Easy replacement of previous products
- Best-in-class equipment: Powerful, extremely robust (IP66), tamper-proof



Mini

Midi

Maxi



EvoSIGNAL Mini - LED Signal Beacon

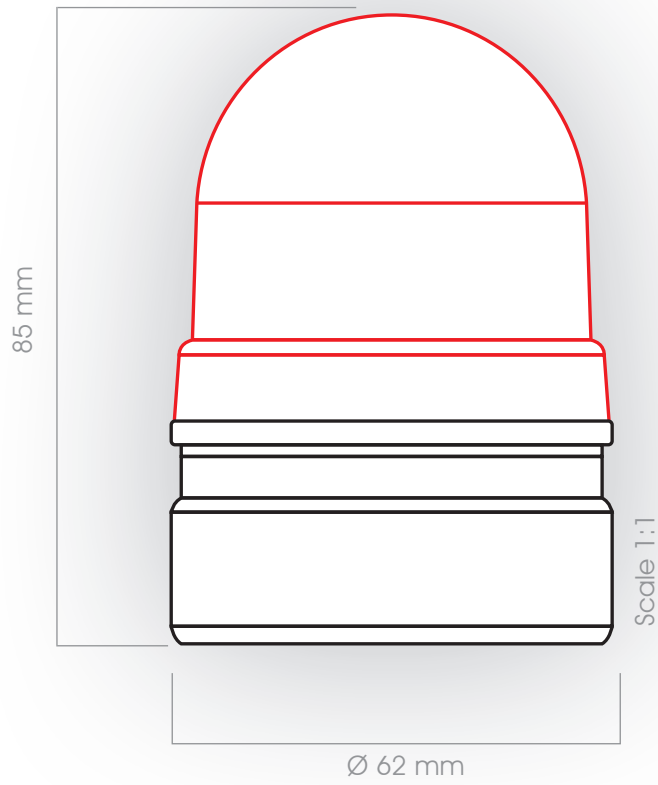

31
TwinLIGHT, TwinFLASH,
TriCOLOUR



6
Mounting adapter

Quick Finder EvoSIGNAL Mini - LED Signal Beacon



12 V AC/DC	
TwinLIGHT	TwinFLASH
Order no.	Order no.
260 110 74	260 120 74
260 210 74	260 220 74
260 310 74	260 320 74
260 410 74	260 420 74
260 510 74	260 520 74

24 V AC/DC	
TwinLIGHT	TwinFLASH
Order no.	Order no.
260 110 75	260 120 75
260 210 75	260 220 75
260 310 75	260 320 75
260 410 75	260 420 75
260 510 75	260 520 75

115-230 V AC	
TwinLIGHT	TwinFLASH
Order no.	Order no.
260 110 60	260 120 60
260 210 60	260 220 60
260 310 60	260 320 60
260 410 60	260 420 60
260 510 60	260 520 60



TriCOLOUR

260 430 75



+ Mounting adapter (compulsory!)

Base mounting



Order no.
260 700 01

Installation mounting M22



Order no.
260 700 03

Installation mounting PG 29



Order no.
260 700 04

Tube mounting



Order no.
260 700 05

Bracket mounting with cable gland

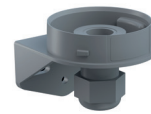

Order no.
260 700 06

Bracket mounting

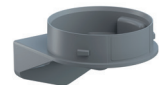

Order no.
260 700 07

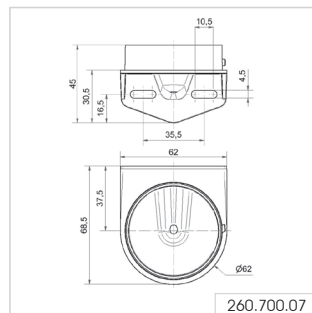
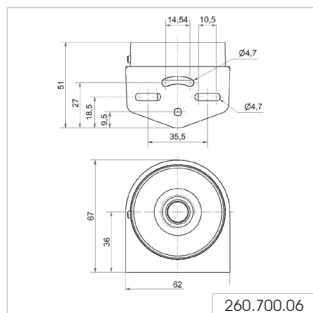
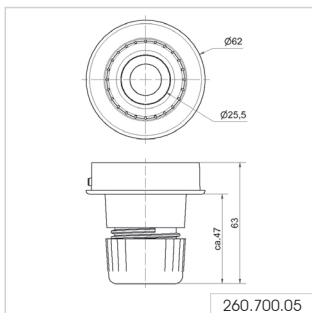
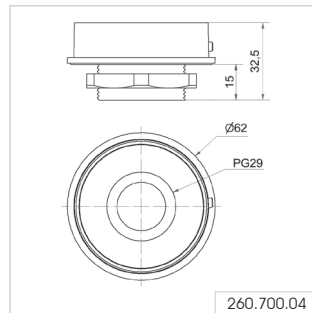
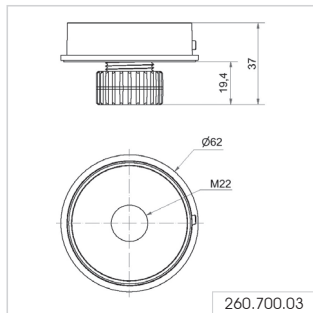
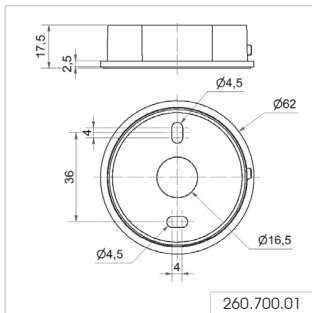



Tube mounting



Bracket mounting with cable gland

EvoSIGNAL Mini - LED Signal Beacon

① TECHNICAL SPECIFICATIONS/ORDER SPECIFICATIONS:

Dimensions (Ø x Height):	62 mm x 85 mm		
Housing:	PC-ABS, grey, high impact		
Lens:	PC, transparent		
Fixing:	Base/Installation/Tube/Wall mounting		
Cable entry:	Cable diameter 8-12 mm		
Connection:	Push-In terminal max.1.5 mm ²		
Flash/Blink frequency:	1 Hz		

TwinLIGHT (Permanent/Blinking)

Voltage:	12 V AC/DC	24 V AC/DC	115-230 V AC
Current consumption:	≤ 90 mA	≤ 75 mA	≤ 45 mA
red	260 110 74	260 110 75	260 110 60
green	260 210 74	260 210 75	260 210 60
yellow	260 310 74	260 310 75	260 310 60
white	260 410 74	260 410 75	260 410 60
blue	260 510 74	260 510 75	260 510 60

TwinFLASH (Flash/EVS)

Voltage:	12 V AC/DC	24 V AC/DC	115-230 V AC
Current consumption:	≤ 70 mA	≤ 75 mA	≤ 45 mA
red	260 120 74	260 120 75	260 120 60
green	260 220 74	260 220 75	260 220 60
yellow	260 320 74	260 320 75	260 320 60
white	260 420 74	260 420 75	260 420 60
blue	260 520 74	260 520 75	260 520 60

TriCOLOUR

Voltage:		24 V AC/DC	
Current consumption:		≤ 90 mA	
Order no.		260 430 75	

✳ ACCESSORIES (COMPULSORY!):

Base mounting	260 700 01
Installation mounting M22	260 700 03
Installation mounting PG 29	260 700 04
Tube mounting	260 700 05
Bracket mounting with cable gland	260 700 06
Bracket mounting	260 700 07

↔ TECHNICAL DIAGRAM:

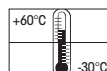
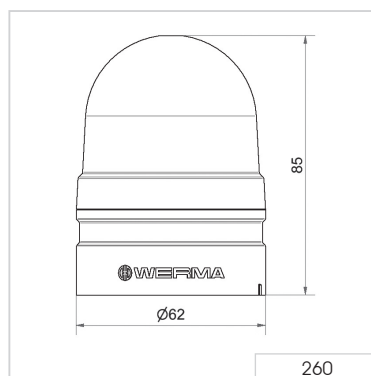

EvoSIGNAL Midi - LED Signal Beacon

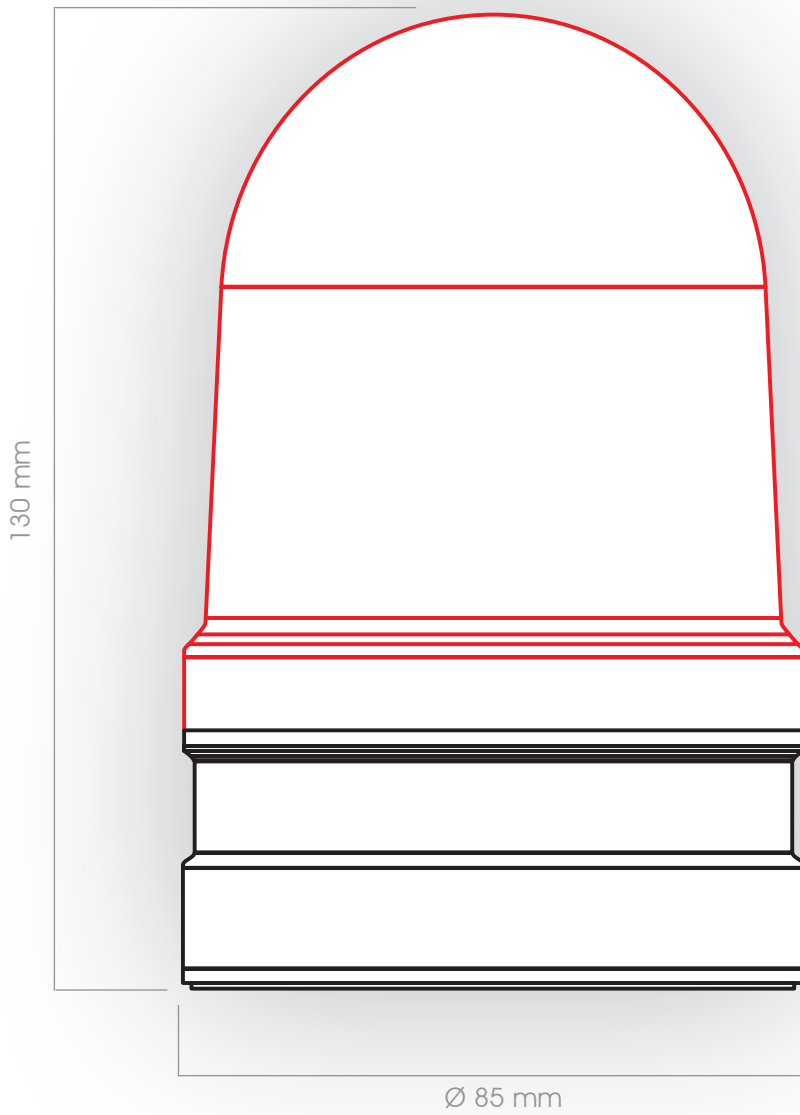

32
TwinLIGHT, TwinFLASH,
TriCOLOUR, Rotating Light



6
Mounting adapter



EvoSIGNAL Midi - LED Signal Beacon



12/24 V AC/DC



TwinLIGHT	TwinFLASH	Rotating
Order no.	Order no.	Order no.
261 110 70	261 120 70	261 140 70
261 210 70	261 220 70	261 240 70
261 310 70	261 320 70	261 340 70
261 410 70	261 420 70	261 440 70
261 510 70	261 520 70	261 540 70
TriCOLOUR		
261 430 70 		

115-230 V AC

TwinLIGHT	TwinFLASH	Rotating
Order no.	Order no.	Order no.
261 110 60	261 120 60	261 140 60
261 210 60	261 220 60	261 240 60
261 310 60	261 320 60	261 340 60
261 410 60	261 420 60	261 440 60
261 510 60	261 520 60	261 540 60
TriCOLOUR		
261 430 60 		

+ Mounting adapter (compulsory!)

Base mounting



Order no.
261 700 01

Base mounting
with cable gland



Order no.
261 700 02

Tube mounting



Order no.
261 700 05

Bracket mounting
with cable gland

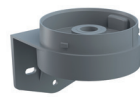

Order no.
261 700 06

Bracket
mounting

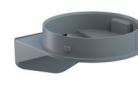

Order no.
261 700 07

Horn



Order no.
261 700 03

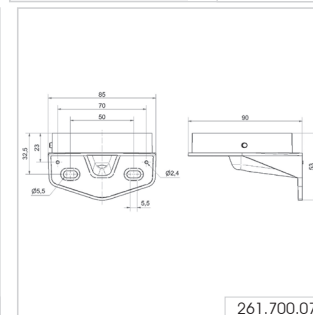
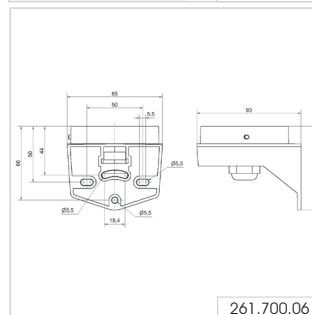
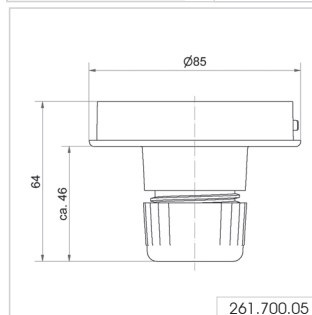
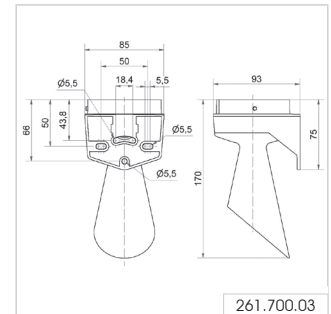
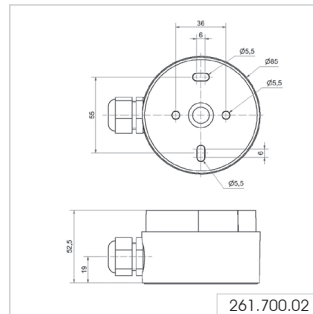
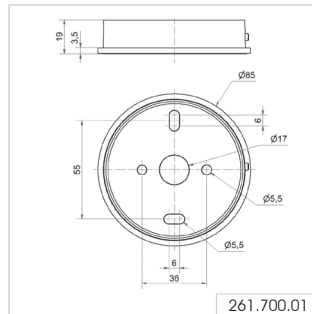
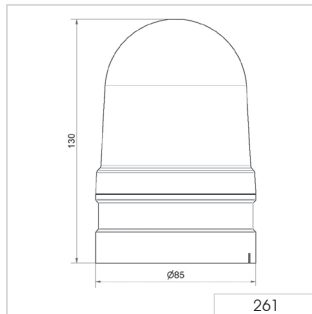

EvoSIGNAL Midi - LED Signal Beacon



Bracket mounting



Tube mounting

① TECHNICAL SPECIFICATIONS/ORDER SPECIFICATIONS:

Dimensions (Ø x Height):	85 mm x 130 mm	
Housing:	PC/ABS, grey, high impact	
Lens:	PC, transparent	
Fixing:	Base/Tube/Wall mounting	
Cable entry:	Cable Diameter 8-12 mm	
Connection:	Push-In terminal max. 1.5 mm ²	

TwinLIGHT

Blinking/Flash frequency:	1 Hz	
Voltage:	12/24 V AC/DC	115-230 V AC
Current consumption:	≤ 185 mA	≤ 65 mA
red	261 110 70	261 110 60
green	261 210 70	261 210 60
yellow	261 310 70	261 310 60
white	261 410 70	261 410 60
blue	261 510 70	261 510 60

TwinFLASH

Blinking/Flash frequency:	1 Hz	
Voltage:	12/24 V AC/DC	115-230 V AC
Current consumption:	≤ 850 mA	≤ 110 mA
red	261 120 70	261 120 60
green	261 220 70	261 220 60
yellow	261 320 70	261 320 60
white	261 420 70	261 420 60
blue	261 520 70	261 520 60

Rotation

Rotation rate:	180 r.p.m.	
Voltage:	12/24 V AC/DC	115-230 V AC
Current consumption:	≤ 130 mA	≤ 110 mA
red	261 140 70	261 140 60
green	261 240 70	261 240 60
yellow	261 340 70	261 340 60
white	261 440 70	261 440 60
blue	261 540 70	261 540 60

TriCOLOUR

Voltage:	12/24 V AC/DC	115-230 V AC
Current consumption:	≤ 145 mA	≤ 50 mA
clear	261 430 70	261 430 60

✂ ACCESSORIES:

Base mounting	261 700 01
Base mounting with cable gland	261 700 02
Tube mounting	261 700 05
Bracket mounting with cable gland	261 700 06
Bracket mounting	261 700 07
Horn	261 700 03

↔ TECHNICAL DIAGRAM:



EvoSIGNAL Maxi - LED Signal Beacon



173 mm

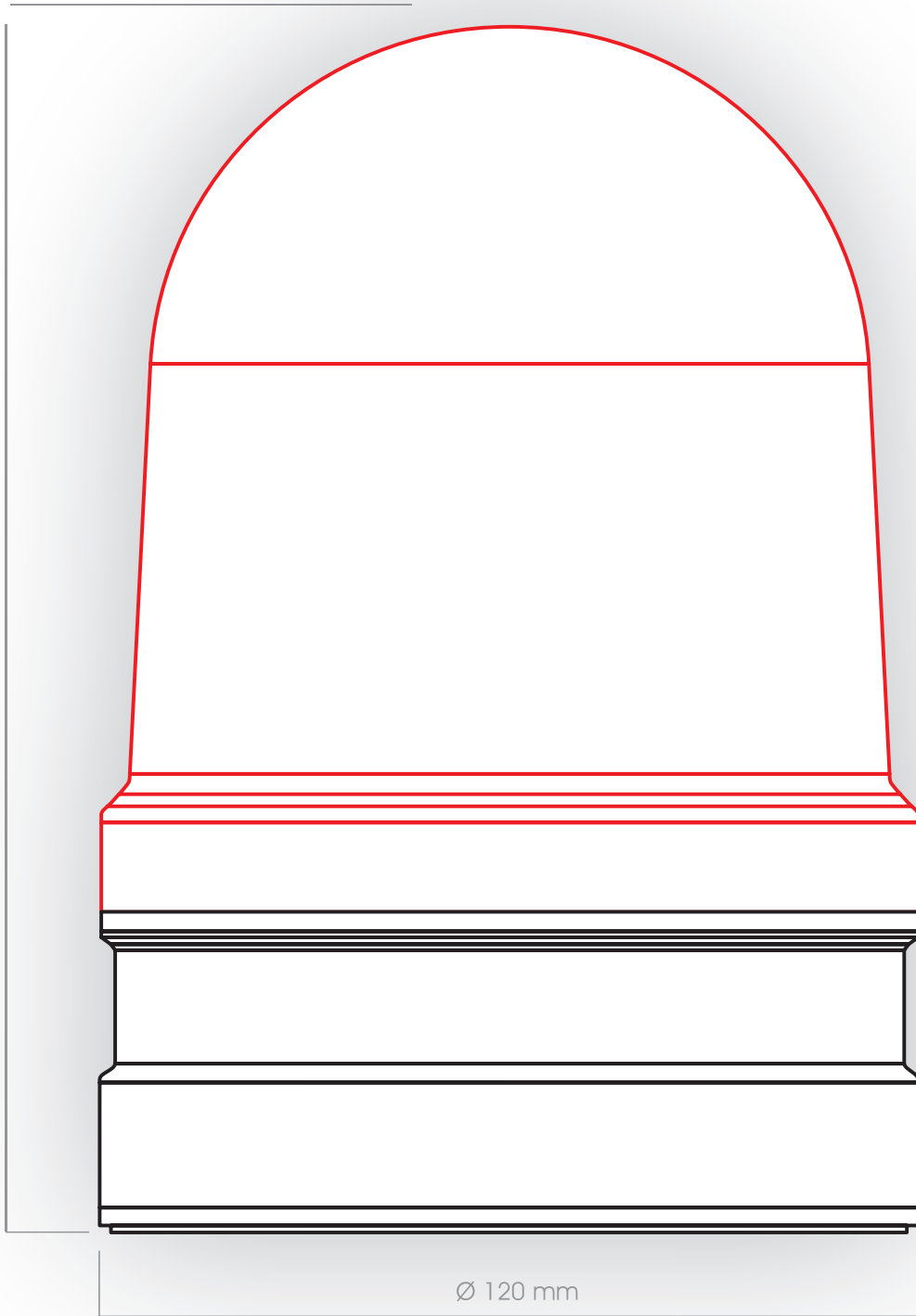

Ø 120 mm

Scale 1:1



30
TwinLIGHT, TwinFLASH,
Rotating Light



4
Mounting adapter

Quick-Finder EvoSIGNAL Maxi - LED Signal Beacon



12/24 V AC/DC		
TwinLIGHT	TwinFLASH	Rotating
Order no.	Order no.	Order no.
262 110 70	262 120 70	262 140 70
262 210 70	262 220 70	262 240 70
262 310 70	262 320 70	262 340 70
262 410 70	262 420 70	262 440 70
262 510 70	262 520 70	262 540 70

115-230 V AC		
TwinLIGHT	TwinFLASH	Rotating
Order no.	Order no.	Order no.
262 110 60	262 120 60	262 140 60
262 210 60	262 220 60	262 240 60
262 310 60	262 320 60	262 340 60
262 410 60	262 420 60	262 440 60
262 510 60	262 520 60	262 540 60

+ Mounting adapter (compulsory!)

Base mounting



Order no.
262 700 01

Base mounting with cable exit at side



Order no.
262 700 02

Bracket mounting with cable gland



Order no.
262 700 06

Bracket mounting with concealed cable entry



Order no.
262 700 07

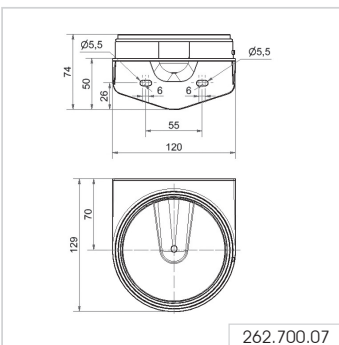
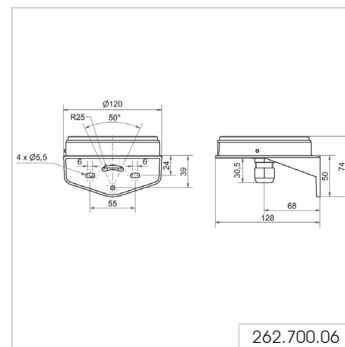
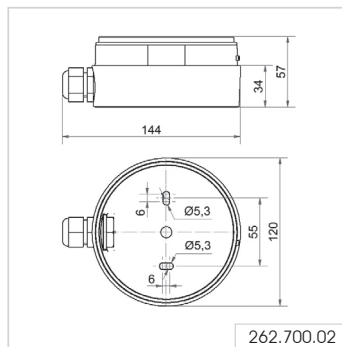
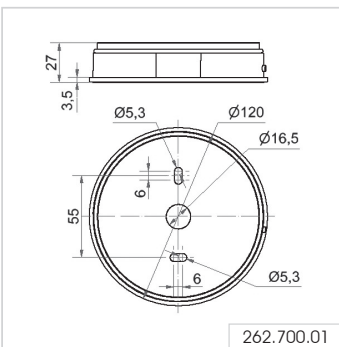



Bracket mounting with cable gland



Base mounting with cable exit at side

EvoSIGNAL Maxi - LED Signal Beacon

① TECHNICAL SPECIFICATIONS/ORDER SPECIFICATIONS:

Dimensions (Ø x Height):	120 mm x 173 mm
Housing:	PC/ABS
Lens:	PC, transparent
Fixing:	Base/Wall/Tube mounting
Cable entry:	Cable Diameter 8-12 mm
Connection:	Push-In terminal max. 1.5 mm ²
Rotation rate:	180 r.p.m.
Flash/Blinking frequency:	1 Hz

TwinLIGHT

Voltage:	12/24 V AC/DC	115-230 V AC
Current consumption:	≤ 700 mA	≤ 165 mA
red	262 110 70	262 110 60
green	262 210 70	262 210 60
yellow	262 310 70	262 310 60
white	262 410 70	262 410 60
blue	262 510 70	262 510 60

TwinFLASH

Voltage:	12/24 V AC/DC	115-230 V AC
Current consumption:	≤ 760 mA	≤ 165 mA
red	262 120 70	262 120 60
green	262 220 70	262 220 60
yellow	262 320 70	262 320 60
white	262 420 70	262 420 60
blue	262 520 70	262 520 60

Rotating

Voltage:	12/24 V AC/DC	115-230 V AC
Current consumption:	≤ 550 mA	≤ 170 mA
red	262 140 70	262 140 60
green	262 240 70	262 240 60
yellow	262 340 70	262 340 60
white	262 440 70	262 440 60
blue	262 540 70	262 540 60

✂ ACCESSORIES:

Base mounting	262 700 01
Base mounting with cable exit at side	262 700 02
Bracket mounting with cable gland	262 700 06
Bracket mounting with concealed cable entry	262 700 07

↔ TECHNICAL DIAGRAM:

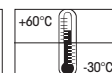
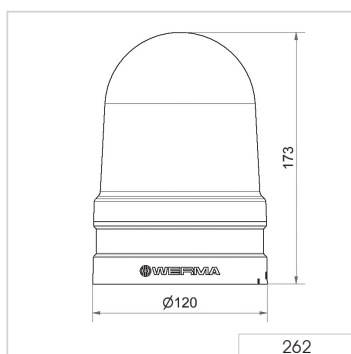

Monitored / Monitorable Beacons for safety applications – 806 / 829 families

Your benefits

For applications where safety is an issue, we recommend WERMA's monitored beacons. These beacons are certified by the TÜV Technical Inspection Agency and can be integrated into the safety assessment of your machinery/plant equipment in accordance with EN 13849-1 and EN 62061.

806 monitorable LED beacons:

- TÜV certified LED light that enables current monitoring

829 monitored LED beacons:

- Built-in monitoring electronics with two potential-free outputs; the light thus achieves PL e as per EN 13849-1 and safety category 4
- Approval confirmed by TÜV certificate
- Maintenance-free LED technology

826 monitored beacons:

- Built-in monitoring electronics with two potential-free outputs; the light thus achieves PL e as per EN 13849-1 and safety category 4
- Approval confirmed with a TÜV certificate

Typical applications

Signalling of faults in applications where safety is an issue

- on machinery and plant equipment
- in building service industry

Installation options

- Base mounting
- Bracket mounting with accessories
- Wire guard accessory to protect against mechanical damage

Features

- Further safety-related products are available on request



Size comparison 806 / 826+829 / EvoSIGNAL Maxi





Bracket (accessory)



Accessories

806 Monitorable LED Permanent Beacon

① TECHNICAL SPECIFICATIONS/ORDER SPECIFICATIONS:

Dimensions (Ø x Height):	70 mm x 97 mm
Housing:	Terminal element: PA-GF, high impact Cap: PC
Lens:	PC, transparent
Fixing:	Base mounting, Bracket mounting
Cable entry:	Cable diameter max. 1.4 mm
Connection:	CAGE CLAMP® technology max. 2.5 mm ²
Duty cycle:	100 %
Current consumption following failure of 3 of the 6 strips:	< 5 mA
Life duration:	Up to 100,000 hrs
Voltage:	24 V DC
Current consumption:	60 mA
yellow	806 350 55
clear	806 450 55

✳ ACCESSORIES:

Bracket, including cable gland	960 000 02
Bracket for 1-sided mounting	975 840 85

! ADDITIONAL INFORMATION:

What does Muting mean?

Muting is the temporary automatic overriding of a safety protection device by means of a control system within the normal operating cycle of a machine. This bridging of the safety protection must be visually displayed in order to prevent staff mistakenly entering a dangerous area.

It is therefore necessary that the signal beacon in such applications can be triggered by failsafe technology and the bulb function can be monitored. The standard colour for muting signalisation is clear; yellow is however also permitted.

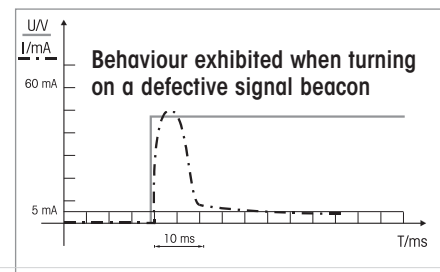
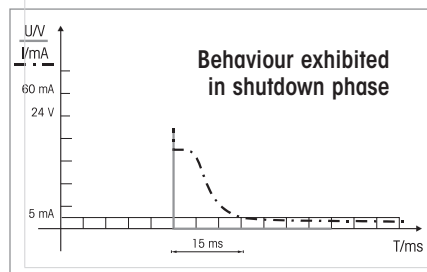

↔ TECHNICAL DIAGRAM:

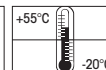
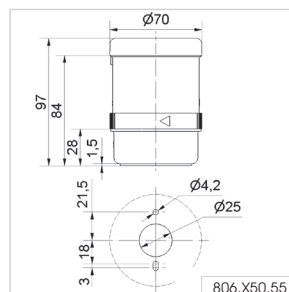

829 Monitored LED Permanent Beacon



Monitored Permanent Beacon with long life, maintenance-free LED technology



Bracket (accessory)

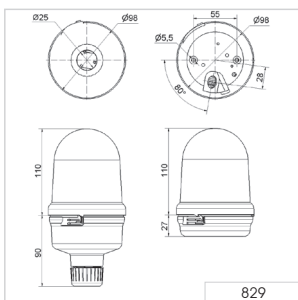

① TECHNICAL SPECIFICATIONS/ORDER SPECIFICATIONS:

Dimensions (Ø x Height):	98 mm x 137 mm
Housing:	PC/ABS-Blend
Lens:	PC, transparent
Fixing:	Base, bracket and tube mounting. Base 975 840 90 must be ordered twice for tube mounting - once as socket for beacon and once as base
Cable entry:	Cable diameter 5-7 mm
Connection:	Screw terminal with wire protection 0.5-1.5 mm ²
Installation position:	Vertical
Cable outlet:	Downwards
Duty cycle:	100 %
Rated voltage:	24 V DC
Input power 24 V DC:	c. 3.5 W
Output current capability:	30 V DC / 100 mA
On state resistance of an output:	Max. 25 Ω
Atmospheric humidity:	≤ 95 % without moisture condensation
Response time, normal operation and with LED failure:	1 ms to 5 ms
in fault cases with safety release:	< 1 s (with short-circuit current ≥ 1 A)
Certification:	EN ISO 13849-1:2008 category 4, Performance Level "e" EN ISO 13849-2:2008 validation
Life duration:	Up to 50,000 hrs
Voltage:	24 V DC
Current consumption:	≤ 150 mA
red	829 170 55
yellow	829 370 55
clear	829 470 55

✂ ACCESSORIES:

Bracket	975 826 05
---------	-------------------

! ADDITIONAL INFORMATION:

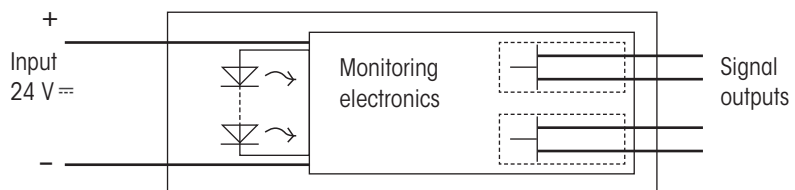

Function

The device is equipped with monitoring electronics which signal the current flow of the beacon back to two electrically isolated, potential-free semiconductor outputs A and B (outputs closed).

If the beacon has not been actuated, both outputs are open. In case of a fault at least one output is opened.

↔ TECHNICAL DIAGRAM:



LED Maxi Beacons – 883/884/885 families

Your benefits

WERMA's Maxi Beacons give flexible signalling over larger distances. The IP65 rated units are ideally suited for use in both indoor and outdoor applications.

838 xenon double flash:

- Very bright, even in direct sunlight and over longer distances

883/884 rotating mirror beacons:

- High intensity light and robust housing
- Easy to connect, without removing the mechanical assembly

Typical applications

Signalling faults and relaying alarms

- In building technology
- For door and gate systems
- On machinery and plant equipment, over long distances

Installation options

- Base mounting
- Tube mounting
- Bracket mounting

Features

- Tamper-proof and shock-resistant up to 20 joules
- Optional wire guard to protect against mechanical damage

883/884 rotating mirror beacons:

- Quiet, with low-wear wheel and disc drive

884 revolving beacon:

- Special Fresnel lenses produce beams of light that can be seen over longer distances even in poor light conditions



Size comparison EvoSIGNAL Midi/Maxi/Heavy Duty



883 Rotating Mirror Beacon



Bracket (accessory)



Plastic bracket, adaptor for tube mounting and wire guard (accessories)

① TECHNICAL SPECIFICATIONS/ORDER SPECIFICATIONS:

Dimensions (Ø x Height):	142 mm x 218 mm	
Housing:	PC/ABS	
Lens:	PC, transparent	
Fixing:	Base mounting, bracket mounting, tube mounting (accessory)	
Cable entry:	Cable diameter 5-7 mm	
Connection:	Screw terminal 0.5 -1.5 mm ²	
Drive:	Wheel and disc drive, motor in centre of gravity	
Mirror rotation rate:	180 r.p.m.	
Life duration LED:	> 50,000 hrs	
Service life of drive:	> 5,000 hrs	
Duty cycle:	100 %	
Voltage:	24 V AC/DC	115 -230 V AC
Current consumption:	250 mA	95 mA
red	883 130 75	883 130 60
green	883 230 75	883 230 60
yellow	883 330 75	883 330 60
blue	883 530 75	883 530 60

Further colours and voltages on request.

✂ ACCESSORIES:

Plastic bracket for wall mounting	975 883 06
Adaptor for tube mounting	975 883 09
Base for tube mounting	975 840 91
Tube, Ø 25 mm, 100 mm long	975 845 10
Tube, Ø 25 mm, 250 mm long	975 840 25
Wire guard, only for base mounting	975 883 08

↔ TECHNICAL DIAGRAM:

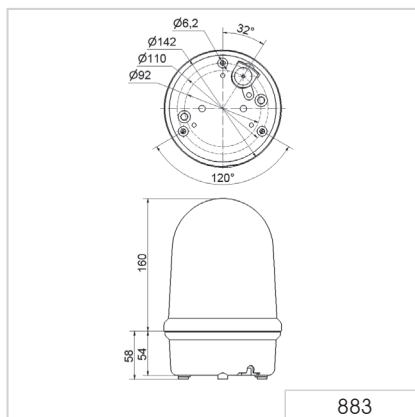



885 Rotating Mirror Beacon

① TECHNICAL SPECIFICATIONS/ORDER SPECIFICATIONS:

Housing:	PC/ABS
Lens:	PC, transparent
Connection:	Screw terminal max. 1.5 mm ²
Cable entry:	Cable diameter 5-7 mm
Installation position:	Standing, Tube mounting if required
Mirror rotation rate:	c. 180 r.p.m.
Life duration LED:	> 50,000 hrs
Service life of drive:	> 5,000 hrs
Duty cycle:	100 %

Base/Bracket mounting

Dimensions (Ø x Height):	98 mm x 151 mm	
Voltage:	24 V AC/DC	115-230 V AC
Current consumption:	175 mA	65 mA
red	885 130 75	885 130 60
green	885 230 75	885 230 60
yellow	885 330 75	885 330 60
blue	885 530 75	885 530 60

Tube mounting

Dimensions (Ø x Height):	98 mm x 200 mm	
Voltage:	24 V AC/DC	115-230 V AC
Current consumption:	175 mA	65 mA
red	885 140 75	885 140 60
green	885 240 75	885 240 60
yellow	885 340 75	885 340 60
blue	885 540 75	885 540 60

✂ ACCESSORIES:

Plastic bracket for wall mounting	975 826 05
Wire guard, galvanised, only for base mounting	975 826 03
Tube Ø 25 mm, all anodised aluminium	
100 mm long	975 845 10
250 mm long	975 840 25
Base for tube mounting, plastic, Ø 25 mm	975 840 90
Base for tube mounting, metal, Ø 25 mm	975 840 91

↔ SCHÉMAS:

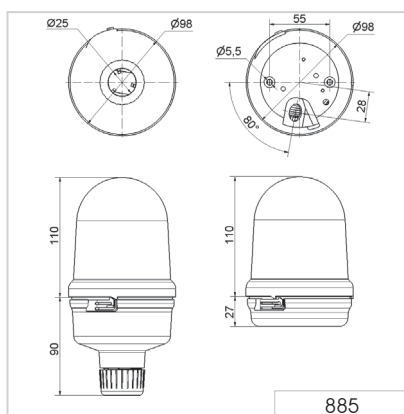

884 Revolving Signal Beacon



Bracket
(accessory)



Plastic bracket, adaptor for tube mounting and wire guard
(accessories)

① TECHNICAL SPECIFICATIONS/ORDER SPECIFICATIONS:

Dimensions (Ø x Height):	142 mm x 218 mm	
Housing:	PC/ABS	
Lens:	PC, transparent	
Fixing:	Base mounting, bracket mounting, tube mounting (accessory)	
Cable entry:	Cable diameter 5-8 mm	
Connection:	Screw terminal 0.5 - 1.5 mm ²	
Drive:	Wheel and disc drive, motor in centre of gravity	
Mirror rotation rate:	60 r.p.m.	
Life duration LED:	> 50,000 hrs	
Service life of drive:	> 5,000 hrs	
Duty cycle:	100 %	
Voltage:	24 V AC/DC	115-230 V AC
Current consumption:	250 mA	95 mA
red	884 130 75	884 130 60
green	884 230 75	884 230 60
yellow	884 330 75	884 330 60
blue	884 530 75	884 530 60

Further colours and voltages on request.

✳ ACCESSORIES:

Plastic bracket for wall mounting	975 883 06
Adaptor for tube mounting	975 883 09
Base for tube mounting	975 840 91
Tube, Ø 25 mm, 100 mm long	975 845 10
Tube, Ø 25 mm, 250 mm long	975 840 25
Wire guard, only for base mounting	975 883 08

↔ TECHNICAL DIAGRAM:

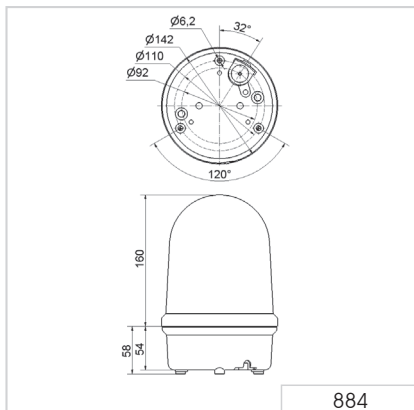



EvoSIGNAL Midi - LED Signal Beacon



Bracket mounting



Tube mounting

TECHNICAL SPECIFICATIONS/ORDER SPECIFICATIONS:

Dimensions (Ø x Height):	85 mm x 130 mm	
Housing:	PC/ABS, grey, high impact	
Lens:	PC, transparent	
Fixing:	Base/Tube/Wall mounting	
Cable entry:	Cable Diameter 8-12 mm	
Connection:	Push-In terminal max. 1.5 mm ²	

Rotation		
Rotation rate:	180 r.p.m.	
Voltage:	12/24 V AC/DC	115-230 V AC
Current consumption:	≤ 130 mA	≤ 110 mA
red	261 140 70	261 140 60
green	261 240 70	261 240 60
yellow	261 340 70	261 340 60
white	261 440 70	261 440 60
blue	261 540 70	261 540 60

ACCESSORIES:

Base mounting	261 700 01
Base mounting with cable gland	261 700 02
Tube mounting	261 700 05
Bracket mounting with cable gland	261 700 06
Bracket mounting	261 700 07
Horn	261 700 03

TECHNICAL DIAGRAM:

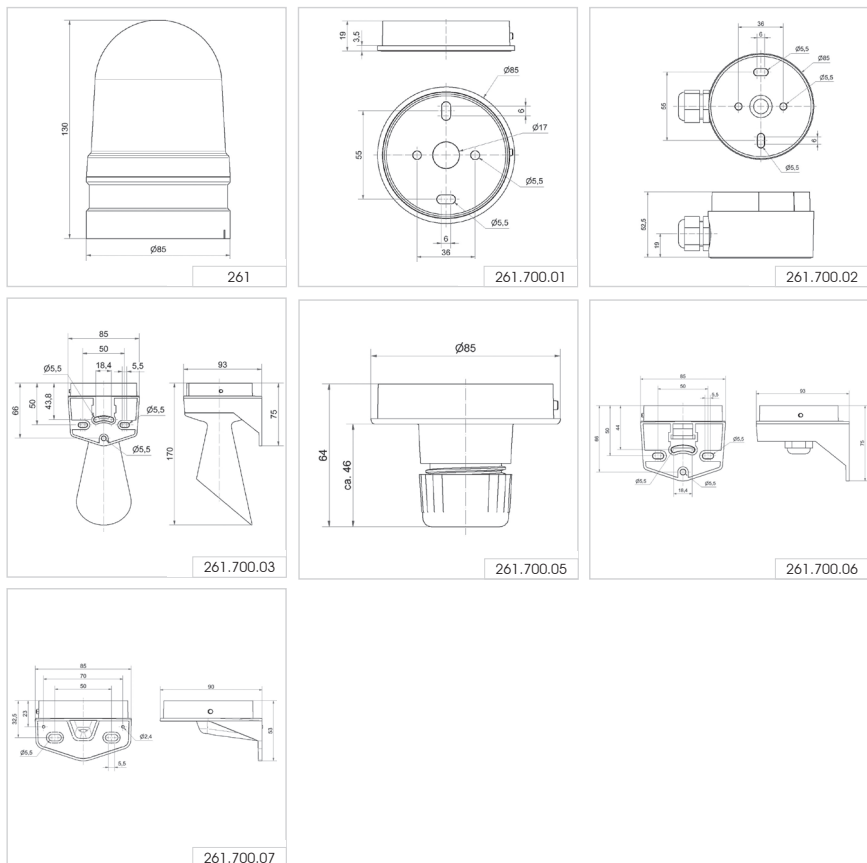

EvoSIGNAL Maxi - LED Signal Beacon



Bracket mounting with cable gland



Base mounting with cable exit at side

① TECHNICAL SPECIFICATIONS/ORDER SPECIFICATIONS:

Dimensions (Ø x Height):	120 mm x 173 mm	
Housing:	PC/ABS	
Lens:	PC, transparent	
Fixing:	Base/Wall/Tube mounting	
Cable entry:	Cable Diameter 8-12 mm	
Connection:	Push-In terminal max. 1.5 mm ²	
Rotation rate:	180 r.p.m.	
Flash/Blinking frequency:	1 Hz	
Rotating		
Voltage:	12/24 V AC/DC	115-230 V AC
Current consumption:	≤ 550 mA	≤ 170 mA
red	262 140 70	262 140 60
green	262 240 70	262 240 60
yellow	262 340 70	262 340 60
white	262 440 70	262 440 60
blue	262 540 70	262 540 60

✳ ACCESSORIES:

Base mounting	262 700 01
Base mounting with cable exit at side	262 700 02
Bracket mounting with cable gland	262 700 06
Bracket mounting with concealed cable entry	262 700 07

↔ TECHNICAL DIAGRAM:

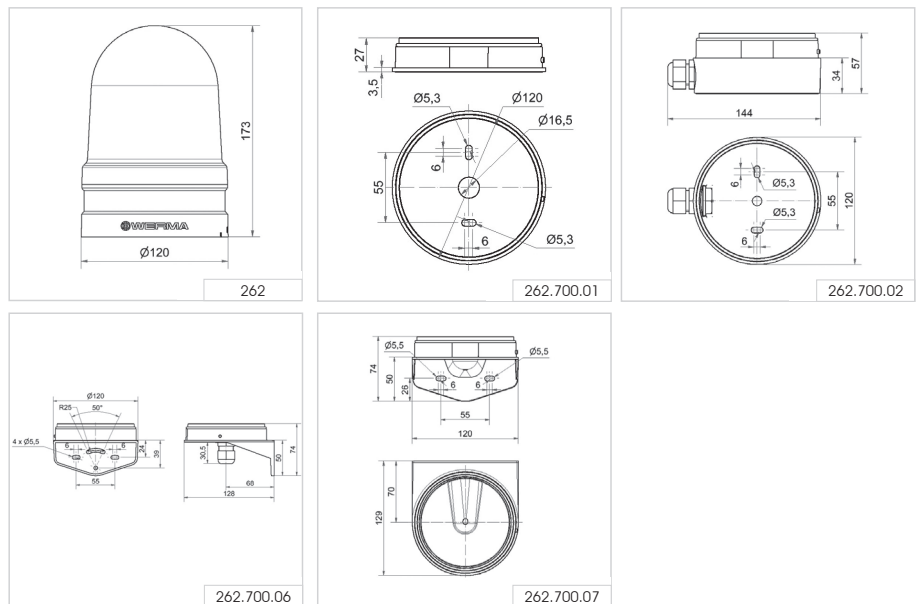

Obstruction Light



Why do obstacles need to be illuminated?

The law stipulates that buildings of a specific height and in the vicinity of airports as well as factory chimneys, towers, masts etc. must be equipped with obstruction lights.

This special lighting makes obstacles visible for pilots in the dark or when visibility is poor. Obstruction lighting is one of the most important aspects of flight safety.

What directives and regulations are there?

The method of marking obstacles to air traffic is laid down by diverse laws, regulations and recommendations. These regulations have a clearly defined sphere of influence and are **internationally interlinked**.

The International Civil Aviation Organisation (**ICAO**) is a special organisation within the United Nations created to establish and develop universal regulations for safety, continuity and economic efficiency in international air traffic. The recommendations of the ICAO are not directly binding in the member states, but must be transformed by them into the appropriate **national legal regulations**.

In **Germany** the Ministry for Transport and Construction Development (**BMVBS**) issues the regulations covering obstruction lighting on buildings. The **ICAO** regulations regarding the methods of marking and lighting aviation obstacles can be found in ICAO Annex 14.

- **"Low intensity obstacle beacon type A"**: a red permanent night-time warning beacon for fixed obstructions with a brightness of 10 cd.
- **"Low intensity obstacle beacon type B"**: a red permanent night-time warning beacon for fixed obstructions with a brightness of 32 cd.

Where are obstacle lights deployed?



- **Germany**: Marking of aviation obstacles by night at any height providing the highest point of the obstacle can be marked.



- **According to ICAO**: Marking of aviation obstacles by night up to 45 m ("Low-intensity Obstacle Light, Type A"), additionally in combination with "medium-intensity obstacle lights"

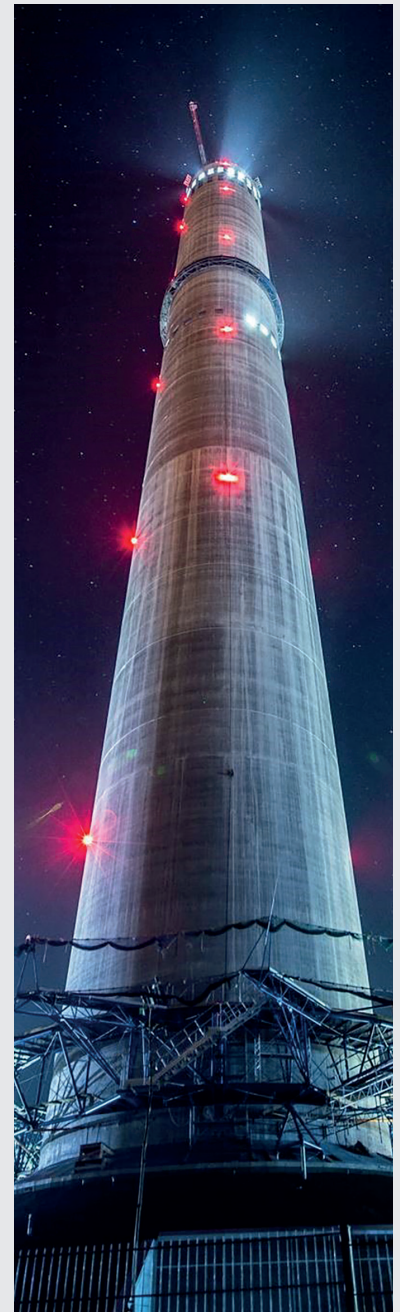

280 Low-intensity LED Obstruction Light Type A and B



LED Obstruction Light Type B



LED Obstruction Light Type A - The adaptor (accessory) allows quick and simple mounting on a tube



Plastic bracket, adaptor for tube mounting (accessories)

① TECHNICAL SPECIFICATIONS/ORDER SPECIFICATIONS:

Dimensions (Ø x Height):	142 mm x 218 mm
Housing:	PC/ABS-Blend
Lens:	PC, transparent, clear
Connection:	Screw terminal 0.5 - 1.5 mm ²
Cable entry:	Cable diameter 5-7 mm
Fixing:	Base mounting, bracket mounting (accessory), tube mounting (accessory)
Duty cycle:	100 %
Life duration:	Up to 50,000 hrs
Current consumption at failure of 2 of the 12 LED strips:	< 50mA

Low-intensity LED Obstruction Light Type A

Voltage:	12-50 V DC		
Current consumption:	500-100 mA		
aviation red	280 410 55		

Low-intensity LED Obstruction Light Type B (includes Type A)

Voltage:	24 V DC	230 V AC	230 V AC (monitorable)
Current consumption:	~ 500 mA	~ 200 mA	~ 200 mA / < 50 mA (Failure mode)
aviation red	280 470 55	280 470 68	280 480 68

✳ ACCESSORIES:

Plastic bracket for wall mounting	975 883 06
Wire guard, only for base mounting	975 883 08
Adaptor for tube mounting	975 883 09

↔ TECHNICAL DIAGRAM:

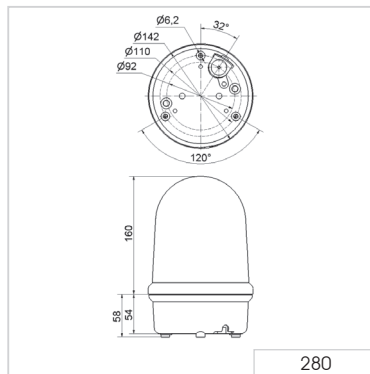



281 Low-intensity LED Obstruction Light Type A and B



LED Obstruction Light Type B



LED Obstruction Light Type A



① TECHNICAL SPECIFICATIONS/ORDER SPECIFICATIONS:

Dimensions (Ø x Height):	165 mm x 205 mm
Housing:	Aluminium, coloured powder coating
Lens:	Reinforced borosilicate glass
Connection:	Screw terminal 0.5 - 1.5 mm ²
Cable entry:	Cable gland M25 x 1.5 mm (included in assembly), Cable diameter 9-17 mm Reducer unit (included in assembly)
Fixing:	Base mounting, tube mounting M25 (no accessory required)
Life duration:	Up to 50,000 hrs

Low-intensity LED Obstruction Light Type A

Voltage:	12-50 V DC		
Current consumption:	500-100 mA		
aviation red	281 410 55		

Low-intensity LED Obstruction Light Type B (includes Type A)

Voltage:	24 V DC	230 V AC	230 V AC (monitorable)
Current consumption:	~ 500 mA	~ 200 mA	~ 200 mA / < 50 mA (Failure mode)
aviation red	281 470 55	281 470 68	281 480 68

← TECHNICAL DIAGRAM:

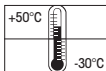
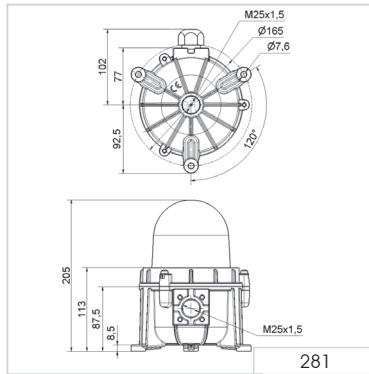

Heavy-Duty Beacons - 839

Your benefits

The heavy-duty beacons have the advantage of a robust and seawater-resistant aluminium housing unit in conjunction with a shock-resistant wire guard. These products are therefore especially suitable for use in harsh environments, locations exposed to seawater, or situations where excellent shock resistance is required.

- Maintenance-free operation permits use in locations where access is difficult
- Optimum protection against even severe mechanical strain or exposure to seawater

Typical applications

Signalling faults and relaying alarms

- In outdoor and indoor areas under extreme conditions
- For maritime applications on ships or in harbour areas

Installation options

- Base mounting
- Bracket mounting

Features

- Special screwed cable gland for equalising the pressure in the housing with the environmental pressure
- IP66 / 67 for use in harsh conditions



Size comparison EvoSIGNAL Midi/EvoSIGNAL Maxi/Heavy Duty





839 LED Permanent Beacon

① TECHNICAL SPECIFICATIONS/ORDER SPECIFICATIONS:

Dimensions (Ø x Height):	153 mm x 189 mm	
Housing:	Black coated aluminium with integral wire guard	
Lens:	PC, transparent	
Fixing:	Base mounting, Bracket mounting (accessory)	
Connection:	Screw terminal 0.5 - 1.5 mm ²	
Cable entry:	Cable gland M20 x 1.5 mm (included in assembly) Cable diameter 6-13 mm	
Installation position:	As required	
Life duration:	Up to 50,000 hrs	
Voltage:	12-50 V DC	230 V AC
Current consumption:	500-100 mA	50 mA
red	839 100 55	839 100 68
yellow	839 300 55	839 300 68

✂ ACCESSORIES:

Mounting bracket	975 839 02
------------------	-------------------

← TECHNICAL DIAGRAM:

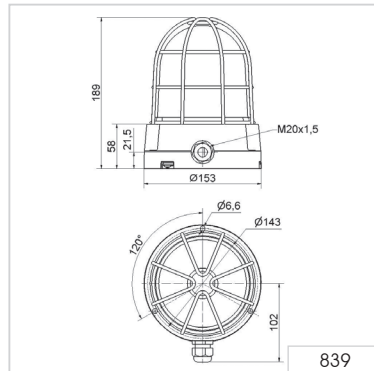

839 LED Rotating Beacon



Mounting bracket
(accessory)

① TECHNICAL SPECIFICATIONS/ORDER SPECIFICATIONS:

Dimensions (Ø x Height):	153 mm x 189 mm	
Housing:	Black coated aluminium with integral wire guard	
Lens:	PC, transparent	
Fixing:	Base mounting, Bracket mounting (accessory)	
Connection:	Screw terminal 0.5 -1.5 mm ²	
Cable entry:	Cable gland M20 x 1.5 mm (included in assembly) Cable diameter 6-13 mm	
Installation position:	As required	
Rotation rate:	c. 180 r.p.m.	
Life duration:	Up to 50,000 hrs	
Voltage:	24 V DC	115-230 V AC
Current consumption:	150 mA	70-180 mA
red	839 120 55	839 120 68
yellow	839 320 55	839 320 68

✂ ACCESSORIES:

Mounting bracket	975 839 02
------------------	-------------------

↔ TECHNICAL DIAGRAM:

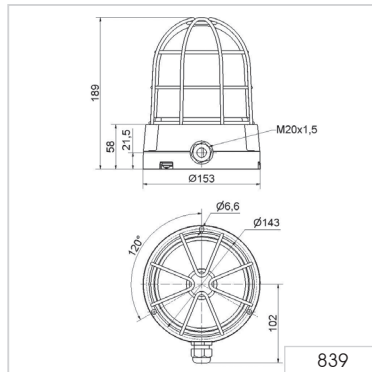

FlexSQUARE – Square shaped beacons

Your benefits

The compact 853 LED beacon is particularly versatile. With an IP67 protection rating, it is suitable for all indoor and outdoor applications, even in harsh environmental conditions.

- Powerful high-output, forward-directed light effect
- Clearly visible, also from the side
- Easy mounting and electrical installation thanks to the elastic, self-sealing, membranes or optional M20 cable gland for mounting on different sides
- Many combinations possible (traffic lights, for example)
- Where space is restricted: Multi-coloured version available, with up to seven colours

153 multi-tone siren:

- Loud audible signal to complement 853 beacon or as a stand-alone product
- Eight signal tones to choose from and a signal escalation option using three different externally triggerable tones

Typical applications

Signalling of faults

- In lift and hoist systems (48 V)
- In building technology

Installation options

- Wall mounting
- Base mounting

Features

- Signal escalation possible with LED permanent light, LED double flash and EVS light in different colours
- Wide range of light effects and voltage options (12V, 24V, 48V and 115-230V)
- With the multi-coloured version, the three basic colours red, yellow and green can be activated with just two PLC outputs. With a third output, a further four colours are available

153 multi-tone siren:

- The sound output can be adjusted remotely



Size comparison
EvoSIGNAL Mini/FlexSQUARE/EvoSIGNAL Maxi



853 LED Permanent Beacon

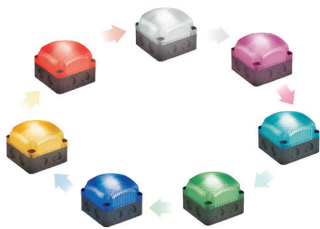
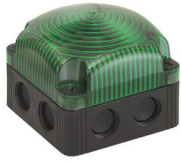

LED Permanent Light multicolour: 7 colours in one beacon: red, yellow, green, clear, blue, violet, turquoise

① TECHNICAL SPECIFICATIONS/ORDER SPECIFICATIONS:

Dimensions (L x H x W):	85 mm x 85 mm x 72 mm
Housing:	PP-GF, black
Lens:	PC, transparent
Connection:	Screw terminal 0.5 - 1.5 mm ² CAGE CLAMP® 0.5 to 1.5 mm ² (Multicolour, RGY)
Fixing:	Wall, base and ceiling mounting
Possible colours:	Red, yellow, green, white, blue, violet, turquoise (multicolour)
Equipment:	Elastic self-sealing membranes for cable entry without tools Eight integrated M20 threads, no nuts required Optional use of a cable gland, thread length of cable gland ≤ 9 mm (accessory)
Assembly:	Incl. snap-on fixing bracket (optional use)
Life duration:	Up to 50,000 hrs

LED Permanent Beacon

Voltage:	12 V DC	24 V DC	48 V AC	115-230 V AC
Current consumption:	< 180 mA	< 80 mA	< 35 mA	< 40 mA
red	853 100 54	853 100 55	853 100 66	853 100 60
green	853 200 54	853 200 55	853 200 66	853 200 60
yellow	853 300 54	853 300 55	853 300 66	853 300 60
clear	853 400 54	853 400 55	853 400 66	853 400 60
blue	853 500 54	853 500 55	853 500 66	853 500 60

LED Permanent Beacon (multicolour)

Voltage:		24 V DC		115-230 V AC
Current consumption:		< 150 mA		< 35 mA
Multicolour		853 480 55		-
RGY (red, green, yellow)		-		853 480 60

✂ ACCESSORIES:

Connector for traffic light combinations	975 853 01
Cable gland M20 x 1.5 mm, 8mm thread length	975 853 02

← TECHNICAL DIAGRAM:

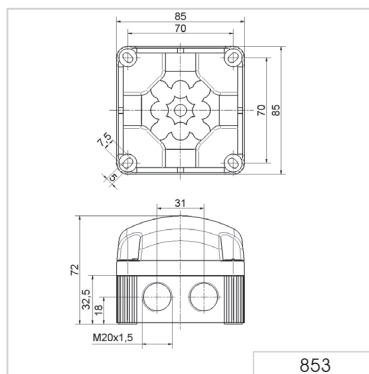

24 V



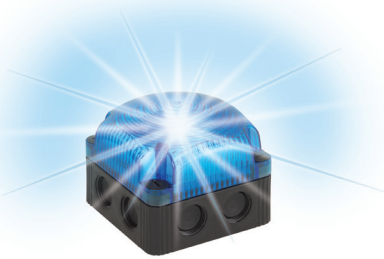

Intense double flash effect
with low power consumption

853 LED Double Flash Beacon

① TECHNICAL SPECIFICATIONS/ORDER SPECIFICATIONS:

Dimensions (L x H x W):	85 mm x 85 mm x 72 mm			
Housing:	PP-GF, black			
Lens:	PC, transparent			
Connection:	Screw terminal 0.5 - 1.5 mm ²			
Fixing:	Wall, base and ceiling mounting			
Equipment:	Elastic self-sealing membranes for cable entry without tools Eight integrated M20 threads, no nuts required Optional use of a cable gland, thread length of cable gland ≤ 9 mm (accessory)			
Assembly:	Incl. snap-on fixing bracket (optional use)			
Life duration:	Up to 50,000 hrs			
Voltage:	12 V DC	24 V DC	48 V AC	115-230 V AC
Current consumption:	< 100 mA	< 80 mA	< 95 mA	< 180 mA
red	853 110 54	853 110 55	853 110 66	853 110 60
green	853 210 54	853 210 55	853 210 66	853 210 60
yellow	853 310 54	853 310 55	853 310 66	853 310 60
clear	853 410 54	853 410 55	853 410 66	853 410 60
blue	853 510 54	853 510 55	853 510 66	853 510 60

✂ ACCESSORIES:

Connector for traffic light combinations	975 853 01
Cable gland M20 x 1.5 mm, 8mm thread length	975 853 02

↔ TECHNICAL DIAGRAM:

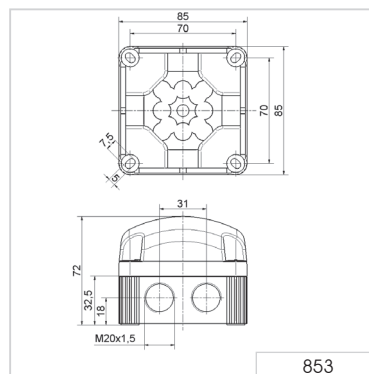

853 LED EVS Beacon



The innovative connector (accessory) enables traffic light combinations to be created in a matter of seconds

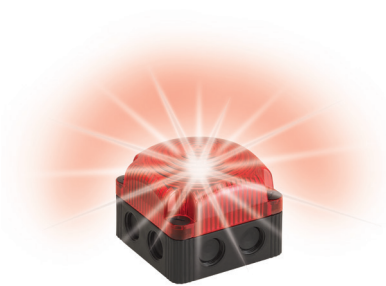

The "EVS" light signal ensures a maximum attention-grabbing effect

① TECHNICAL SPECIFICATIONS/ORDER SPECIFICATIONS:

Dimensions (L x H x W):	85 mm x 85 mm x 72 mm			
Housing:	PP-GF, black			
Lens:	PC, transparent			
Connection:	Screw terminal 0.5 - 1.5 mm ²			
Cable entry:	Cable diameter max. 8 mm, optional cable gland M20 (accessory)			
Fixing:	Wall, base and ceiling mounting			
Equipment:	Elastic self-sealing membranes for cable entry without tools Eight integrated M20 threads, no nuts required Optional use of a cable gland, thread length of cable gland ≤ 9 mm (accessory)			
Assembly:	Incl. snap-on fixing bracket (optional use)			
Life duration:	Up to 50,000 hrs			
Voltage:	12 V DC	24 V DC	48 V AC	115-230 V AC
Current consumption:	< 400 mA	< 200 mA	< 95 mA	< 160 mA
red	853 120 54	853 120 55	853 120 66	853 120 60
green	853 220 54	853 220 55	853 220 66	853 220 60
yellow	853 320 54	853 320 55	853 320 66	853 320 60
clear	853 420 54	853 420 55	853 420 66	853 420 60
blue	853 520 54	853 520 55	853 520 66	853 520 60

✂ ACCESSORIES:

Connector for traffic light combinations	975 853 01
Cable gland M20 x 1.5 mm, 8mm thread length	975 853 02

← TECHNICAL DIAGRAM:

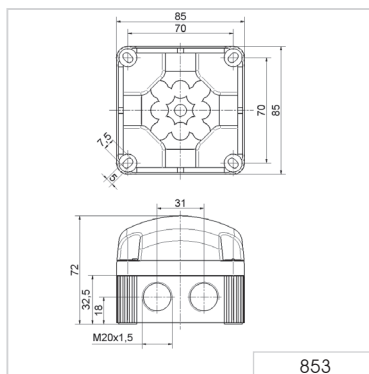



The innovative connector (accessory) enables traffic light combinations to be created in a matter of seconds

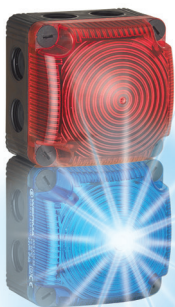

Three highly visible light effects are available



The LED beacon can be used with the sounder

853 LED Traffic Light

① TECHNICAL SPECIFICATIONS/ORDER SPECIFICATIONS:

Dimensions (L x H x W):	85 mm x 85 mm x 72 mm	
Housing:	PP-GF, black	
Lens:	PC, transparent	
Connection:	Screw terminal 0.5 - 1.5 mm ² CAGE CLAMP® 0.5 - 1.5 mm ² (Multicolour, RGY)	
Fixing:	Wall, base and ceiling mounting	
Possible colours:	Red, green, yellow, clear, blue	
Operating voltage:	12 V DC, 24 V DC, 115-230 V AC	
Current consumption:	Max. 80 mA at 24 V (LED Permanent Beacon) Max. 80 mA at 24 V (LED Double Flash Beacon) Max. 200 mA at 24 V (LED EVS Beacon) Max. 150 mA at 24 V (Multicolour)	
Equipment:	Eight self-sealing membranes for cable entry without tools Eight integrated M20 threads, no nuts required Optional use of a cable gland, thread length of cable gland ≤ 9 mm (accessory)	
Assembly:	Incl. snap-on fixing bracket (optional use)	
Life duration:	Up to 50,000 hrs	
LED Permanent Beacon 853		see page 137
LED Permanent Beacon 853 (multicolour)		see page 137
LED Permanent Beacon 853 (RGY)		see page 137
LED Double Flash Beacon 853		see page 138
LED EVS Beacon 853		see page 139
Sounder 153		see next page

✳ ACCESSORIES:

Connector for traffic light combinations	975 853 01
Cable gland M20 x 1.5 mm, 8mm thread length	975 853 02

↔ TECHNICAL DIAGRAM:

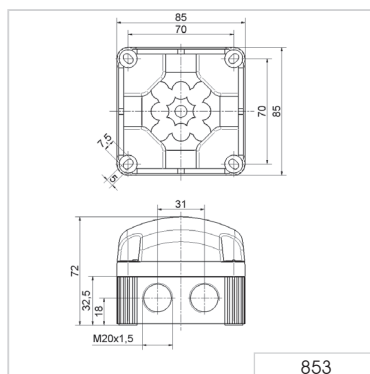

853/153 Sounder/ LED Beacon Combination



The innovative connector (accessory) enables traffic light combinations to be created in a matter of seconds

TECHNICAL SPECIFICATIONS/ORDER SPECIFICATIONS:

Dimensions (L x H x W):	85 mm x 85 mm x 72 mm			
Housing:	PP-GF, black			
Lens:	LED Beacon 853: PC, transparent Sounder 153: PC, tinted black			
Connection:	Screw terminal 0.5 - 1.5 mm ²			
Cable entry:	Cable diameter max. 8 mm, optional Cable gland M20 (accessory)			
Fixing:	Wall and ceiling mounting			
Current consumption:	Max. 200 mA at 24 V			
Equipment:	Eight self-sealing membranes for cable entry without tools Eight integrated M20 threads, no nuts required Optional use of a cable gland, thread length of cable gland ≤ 9 mm (accessory)			
Assembly:	Incl. snap-on fixing bracket (optional use)			
Voltage:	12 V DC	24 V DC	48 V AC	115-230 V AC
Current consumption:	70 mA	120 mA	150 mA	75 mA (115 V) 150 mA (230 V)
Order no.:	153 000 54	153 000 55	153 000 66	153 000 60

The technical specifications and order specifications of the LED Beacons can be found at www.werma.com or on page 137 (LED Permanent Beacon), page 138 (LED Double Flash Beacon) and page 139 (LED EVS Beacon).

ACCESSORIES:

Connector for traffic light combinations	975 853 01
Cable gland M20 x 1.5 mm, 8mm thread length	975 853 02

TONE TYPES AND FREQUENCIES:

Tone	Tone type	Tone	Tone type
1	Continuous tone (c. 3000 Hz)	5	800 - 970 Hz rising @ 1 H
2	Horn tone (c. 110 Hz)	6	2400 - 2850 Hz rising @ 7 Hz
3	1 Hz tone (c. 3,0 kHz)	7	1200 - 500 Hz falling @ 1 Hz
4	20 Hz whistle tone (c. 3,0 kHz)	8	Alternating tone 800 Hz/1200 Hz@1 Hz

TECHNICAL DIAGRAM:

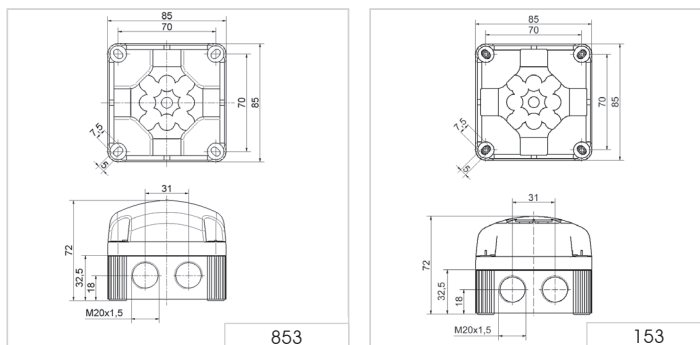

12 V, 24 V		48 V, 115-230 V						

Traffic Lights - 890/895/894

Your benefits

Signal lights and traffic lights from the 890/895/894 range provide reliable signalling, both as single lights or as combined signalling lights.

Modular traffic lights 890 and multi-tone sounder 190:

- Cost-effective LED traffic light with clear lenses
- Easy installation in just a few steps and with any combination of 4 lights

Multi-colour variant 890 (RGY):

- Drastic reduction in number of variants by combining three light colours in a single product – Ideal where space is restricted
- Additional high-output audible signalling of up to 110 dB(A) available in combination with multi-tone sounder/vocal alarm 190

Compact LED traffic light 894 for extreme ambient conditions:

- With high IP65/IP69K protection rating for use in extremely harsh conditions

Typical applications

- Garages and car parks
- Access control or buildings
- Traffic regulation on construction sites
- Signalling for loading bays
- Car washes/washing areas

Installation options

Modular traffic light 890:

- Direct mounting or bracket mounting of up to 4 lights with fixing bracket

Compact LED traffic light 894:

- Wall mounting and tube mounting with additional adapter

Features

190 Vocal Alarm:

- The vocal alarm enables the high-output playback of spoken messages, music and tones provided in mp3 format



Size comparison Midi/Traffic Lights



890 LED Beacon/LED Traffic Light



LED Permanent Beacon



LED Traffic Light Combination with mounting bracket (accessory)



Clear lenses ensure effective signalling even in direct sunlight

① TECHNICAL SPECIFICATIONS/ORDER SPECIFICATIONS:

Dimensions (Ø x Height):	150 mm x 154 mm
Housing:	PC/ABS-Blend, grey
Lens:	PC, transparent
Fixing:	Base mounting, bracket mounting (accessory), tube mounting (accessory)
Cable entry:	From top or bottom with cable gland M20 x 1.5 mm or from the back with rubber grommet Ø 6-12 mm, included in assembly.
Colours:	Red, green, yellow
Connection:	CAGE CLAMP® 0.5 - 1.5 mm ²
Installation position:	As required
Life duration:	Up to 50,000 hrs

LED Beacon/LED Traffic Light

Voltage:	12-24 V DC	115-230 V AC
Current consumption:	< 260 mA	< 35 mA
red	890 120 55	890 120 68
green	890 220 55	890 220 68
yellow	890 320 55	890 320 68

LED Permanent Light (RGY)

Voltage:	12-24 V DC	230 V AC
Current consumption:	< 220 mA	< 40 mA
RGY (red, green, yellow)	890 480 55	890 480 68

✂ ACCESSORIES:

FIXING BRACKET

Fixing bracket for one beacon	975 890 33
Fixing bracket for two beacons	975 890 34
Fixing bracket for three beacons	975 890 35
Fixing bracket for four beacons	975 890 37

Mounting material and connecting grommet included in assembly. Further information can be found on page 144.

CONNECTING GROMMET

Connecting grommet for traffic light combinations	975 890 25
---	-------------------

! ADDITIONAL INFORMATION:

Traffic light configurator at www.werma.com

↔ TECHNICAL DIAGRAM:

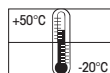
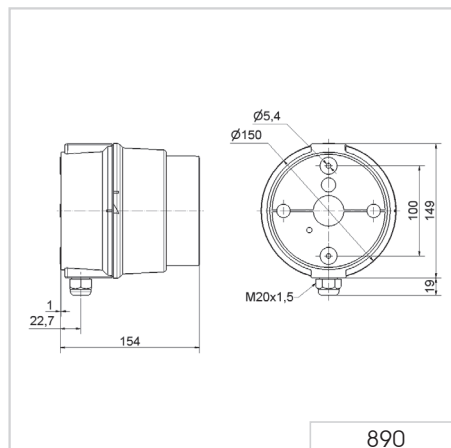



High-output traffic light combination



Vocal alarm 190

890/190 (LED) Beacon 890/Multi-Tone Sounder 190/Vocal alarm 190 Combination

① TECHNICAL SPECIFICATIONS/ORDER SPECIFICATIONS:

(LED-)Beacon/Sounder 190/Vocal Alarm 190

Dimensions (Ø x Height):	150 mm x 154 mm (890) 150 mm x 127 mm (190) 150 mm x 148 mm (Vocal Alarm 190)
Housing:	PC/ABS-Blend, grey
Lens:	PC, transparent
Fixing:	Base mounting, fixing bracket (accessory)
Cable entry:	From top or bottom with cable gland M20 x 1.5 mm or from the back with rubber grommet Ø 6-12 mm, included in assembly
Connection:	CAGE CLAMP® 0.5 - 1.5 mm ²

Vocal Alarm 190

Sound output:	Adjustable, up to 110 dB
File Transfer:	Via USB connection and provided software
Possible data format:	mp3 and wav files
Number of sequences:	15 files can be remotely triggered or one sequence with max. 50 files
Suitable for:	Windows®, System requirements - see Handbook
Assembly:	Vocal alarm, USB connection cable and software

Multi-Tone Sounder 190

Voltage:	10-30 V DC	115 V AC	230 V AC
Current consumption:	< 180 mA	< 55 mA	< 30 mA
grey	190 000 55	190 000 67	190 000 68

Vocal Alarm 190

Voltage:	24 V DC
Current consumption:	< 500 mA Low Power < 1500 mA High Power
grey	190 020 55

LED Beacon 890 see page 143

Permanent Beacon 890 see page 146

✂ ACCESSORIES:

Fixing bracket, tube adaptor and connecting grommet see page 144

🎵 TONE TYPES AND FREQUENCIES:

Selectable via DIP switch, see tone table on page 180.

↔ TECHNICAL DIAGRAM:

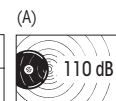
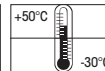
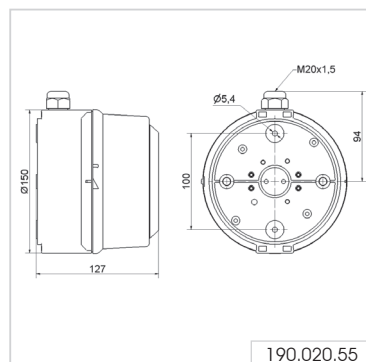

895 Permanent Beacon



① TECHNICAL SPECIFICATIONS/ORDER SPECIFICATIONS:

Dimensions (Ø x Height):	150 mm x 148 mm
Housing:	PC/ABS-Blend, grey
Lens:	PC, transparent
Socket:	E27 max. 25 W with adhesive stickers E27 max. 15 W
Fixing:	Base mounting, tube mounting and fixing bracket (accessory)
Connection:	Screwed cable gland 0.5 - 1.5 mm ²
Cable entry:	From top or bottom with cable gland M20 x 1.5 mm or from the back with rubber grommet Ø 6-12 mm
Voltage:	12-230 V AC/DC
red	895 100 00
green	895 200 00
yellow	895 300 00
clear	895 400 00
blue	895 500 00
Bulb not included in assembly.	

✂ ACCESSORIES:

Fixing bracket, additional reflector, Bulbs and LED Bulbs, Adhesive Stickers see Permanent/Traffic Light Beacon (page 147).

← TECHNICAL DIAGRAM:

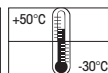
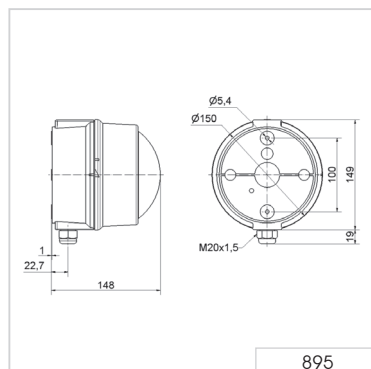



Permanent Beacon

Traffic Light Combination
with mounting bracket
(accessory)

890 Permanent/Traffic Light

① TECHNICAL SPECIFICATIONS/ORDER SPECIFICATIONS:

Dimensions (Ø x Height):	150 mm x 154 mm
Housing:	PC/ABS-Blend, grey
Lens:	PC, transparent
Socket:	E27 max. 25 W for 890 X00 00 with adhesive stickers E27 max. 15 W
Fixing:	Base mounting, fixing bracket (accessory), tube mounting (accessory)
Connection:	Screwed cable gland 0.5 - 1.5 mm ²
Cable entry:	From top or bottom with cable gland M20 x 1.5 mm or from the back with rubber

PERMANENT BEACON

Voltage:	12-230 V AC/DC
red	890 100 00
green	890 200 00
yellow	890 300 00
clear	890 400 00
blue	890 500 00

Further colours and voltages on request.

✳ ACCESSORIES: SEE NEXT PAGE

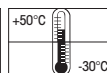

890 Permanent/Traffic Light Beacon



Beacon 890 in combination with Multi-Tone Sounder 190 (see page 144)



The adaptor (accessory) allows quick and simple mounting on a tube (Ø 75 mm)



890 with adhesive sticker (accessory)

✂ ACCESSORIES:

FIXING BRACKET

Fixing bracket for one beacon	975 890 33
Fixing bracket for two beacons	975 890 34
Fixing bracket for three beacons	975 890 35
Fixing bracket for four beacons	975 890 37

Mounting material and connecting grommet included in assembly. Further information can be found on page 148.

CONNECTING GROMMET

Connecting grommet for traffic light combinations	975 890 25
---	------------

REFLECTOR

Additional reflector for 890 X00 00	975 890 02
-------------------------------------	------------

ADAPTER

Tube adapter	975 890 36
--------------	------------

BULBS

LED bulb premium E27, 24 V	956 X20 75
LED bulb premium E27, 115 V	956 X20 67
LED bulb premium E27, 230 V	956 X20 68
For colours see page 149	
LED Bulb E27, 115 V AC, white	956 050 67
LED Bulb E27, 230 V AC, white	956 050 68
LED Bulb E27, 12-24 V AC/AC, white	956 050 75

ADHESIVE STICKERS:

→	975 890 52
STOP	975 890 53
START	975 890 54
⚡	975 890 64
👤	975 890 65

↔ TECHNICAL DIAGRAM:

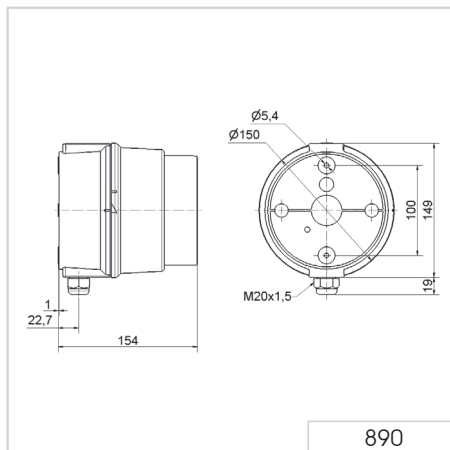



Fixing bracket for (LED) Beacons 890 and Multi-Tone Sounder 190



The fixing bracket can be mounted pointing inwards or outwards

890 Fixing bracket for 890/190

① TECHNICAL SPECIFICATIONS/ORDER SPECIFICATIONS:

Material Fixing bracket:	PC/ABS-Blend, grey
Material Connecting Grommet:	PA 6.6
Assembly:	Fixing bracket with mounting material and connecting grommet
Suitable for:	LED Beacon/LED Traffic Light 890 Permanent/Traffic Light Beacon 890 Multi-Tone Sounder 190
Fixing bracket for one beacon	975 890 33
Fixing bracket for two beacons	975 890 34
Fixing bracket for three beacons	975 890 35
Fixing bracket for four beacons	975 890 37

← TECHNICAL DIAGRAM:

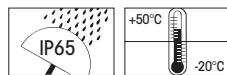
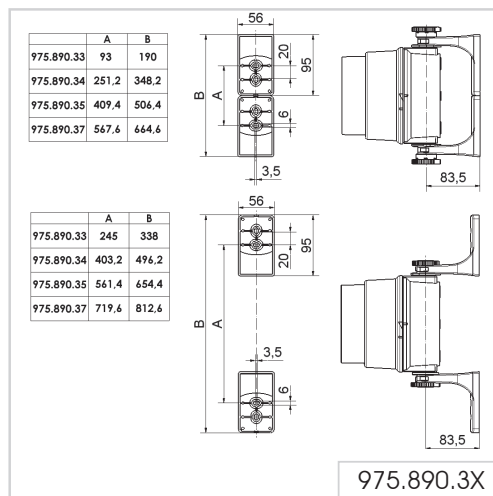

956 LED Bulb E27 premium



Suitable for use in
Permanent/Traffic Light
Beacons 890 (see page 146)

① TECHNICAL SPECIFICATIONS/ORDER SPECIFICATIONS:

Socket:	E27		
For use with:	890, 895		
Slight deviations in the form of the bulbs are possible.			
Voltage:	24 V AC/DC	115 V AC	230 V AC
Current consumption:	≤ 20 mA	≤ 30 mA	≤ 20 mA
red	956 120 75	956 120 67	956 120 68
green	956 220 75	956 220 67	956 220 68
yellow	956 320 75	956 320 67	956 320 68

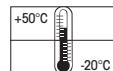



894 LED Traffic Light (IP69k)



LED Traffic Light (3 tier)



The direction of the optical signal can be individually adjusted



Clear lenses ensure effective signalling even in direct sunlight

① TECHNICAL SPECIFICATIONS/ORDER SPECIFICATIONS:

Dimensions (Ø x Height):	2 tier: 85 mm x 309 mm x 136 mm 3 tier: 85 mm x 394 mm x 136 mm	
Housing:	PC/ABS, grey	
Lens:	PC, transparent	
Fixing:	Wall mounting, tube mounting (accessory)	
Cable entry:	Cable diameter max. 13 mm	
Connection:	Screw terminal 0.5 - 1.5 mm ²	
Installation position:	Vertical/hanging	
Duty cycle:	100 %	
Life duration:	Up to 50,000 hrs	
Voltage:	24 V DC	115-230 V AC
Current consumption:	60 mA (red/yellow)	30 mA per tier
	120 mA (green)	at 230 V/50 Hz
red/green	894 160 55	894 160 68
red/yellow/green	894 180 55	894 180 68

✂ ACCESSORIES:

Fixing bracket underneath	975 894 01
---------------------------	-------------------

↳ TECHNICAL DIAGRAM:

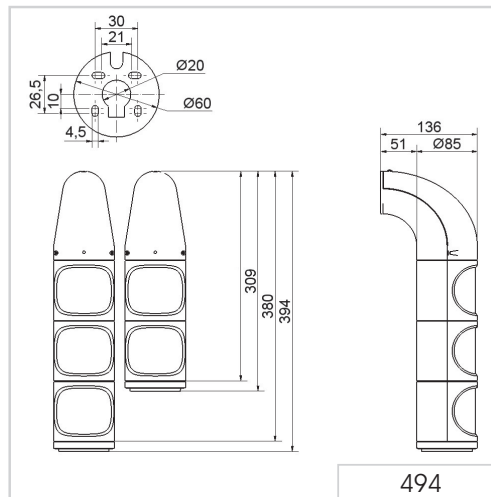

894 LED Traffic Light (IP69k)



The direction of the optical signal can be individually adjusted

① TECHNICAL SPECIFICATIONS/ORDER SPECIFICATIONS:

Dimensions (Ø x Height):	2 tier: 85 mm x 309 mm x 136 mm 3 tier: 85 mm x 394 mm x 136 mm	
Housing:	PC/ABS, grey	
Lens:	PC, transparent	
Fixing:	Wall mounting, tube mounting (accessory)	
Cable entry:	Cable diameter max. 13 mm	
Connection:	Screw terminal 0.5 - 1.5 mm ²	
Installation position:	Vertical/hanging	
Duty cycle:	100 %	
Life duration:	Up to 50,000 hrs	
Voltage:	24 V DC	115-230 V AC
Current consumption:	60 mA (red/yellow)	30 mA per tier at 230 V/50 Hz
red/green	894 060 55	894 060 68
red/yellow/green	894 080 55	894 080 68

↔ TECHNICAL DIAGRAM:

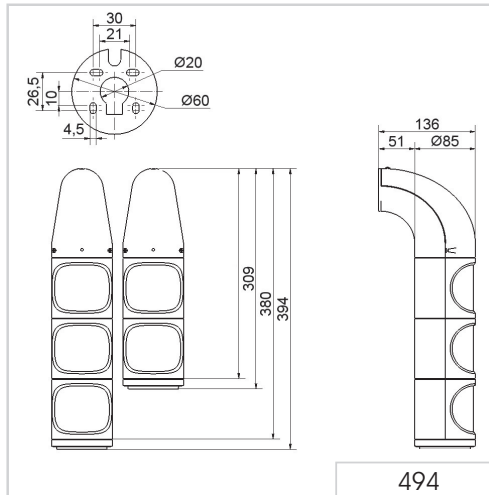





Horns & Sirens

Overview Buzzer, Sirens, Horns and Sounders

Audible signals are everywhere!

Audible signals warn, protect and guide us in the modern industrial world. They function where caution, prudence and clarity are imperative, indicate emergencies and demand direct action. They are globally understood, irrespective of language, written or spoken.





Audible signals are deployed where an optical signal is insufficient or inappropriate. The basic signal is provided by one or more tones or a sequence of tones, raising awareness and alerting to a specific danger.



Overview Buzzer, Sirens, Horns and Sounders					
Product type		Installation	Free-standing	Free-standing	Free-standing
Category	Product range	Installation Sirens and Buzzer	EvoSIGNAL Mini	EvoSIGNAL Midi	Horns & Sounders
Dimensions (Ø x Height)*		See technical specifications			
Dimensions (L x H x W)		See technical specifications			
Voltage	12 V	●	●	●	●
	24 V	●	●	●	●
	30 V				
	48 V	●			●
	115 V	●	●	●	●
	230 V	●	●	●	●
Audible	Continuous tone	●	●		●
	Pulse tone	●	●		●
	Multi-tone sounder	●		●	●
	Horn				●
	Alternating tone				●
	Vocal alarm				
Alarm bell					
Protection rating		IP30-65	IP33-65	IP66	IP33-65
Page		Page 158	Page 167	Page 168	Page 171

* Technical diagrams can be found on the product page



			
Free-standing	Free-standing	Free-standing	Free-standing
Design Multi-Tone Sounder	Vocal alarm	Heavy Duty Multi-Tone Sounder	Alarm Bell
See technical specifications			
●		●	
●	●	●	●
●		●	
●		●	●
●		●	
	●		
			●
IP65	IP65	up to IP67	IP66
Page 180	Page 183	Page 185	Page 192

Installation Buzzers and Sounders

Your benefits

WERMA Installation Buzzers and Sounders have been specifically designed for easy installation in control panels.

- Quick and easy installation
- Tamper-proof when installed
- Minimal protrusion from panel installations where space is tight

Typical applications

Signalling faults or status messages

- in control cabinets

Installation options

- Installation mounting

Features

- Proven piezo technology (except 382)

107, 109, 110, 111

- High IP65 protection rating for outdoor applications
- Easy to connect using a plug-in connection
- Up to 8 tones for signalling different statuses



107 Electronic Installation Buzzer



① TECHNICAL SPECIFICATIONS/ORDER SPECIFICATIONS:		
Dimensions (Ø x Height):	28 mm x 12 mm (Protrusion from panel)	
Housing:	PA fibreglass, high-impact	
Tone frequency:	c. 2,400 Hz / c. 3,200 Hz (12 V)	
Tone type:	Continuous tone or pulse tone with approx. 1 Hz	
Fixing:	Installation mounting for Ø 22.5 mm (M22)	
Connection:	Connector plug with screw terminal max. 1.5 mm ²	
Life duration:	> 5,000 hrs	
Voltage:	12-24 V AC/DC	115-230 V AC
Current consumption:	8 mA	12 mA
Continuous tone	107 000 70	107 000 60
Pulse tone	107 010 70	107 010 60

↔ TECHNICAL DIAGRAM:



Simple connection by means of connector plug

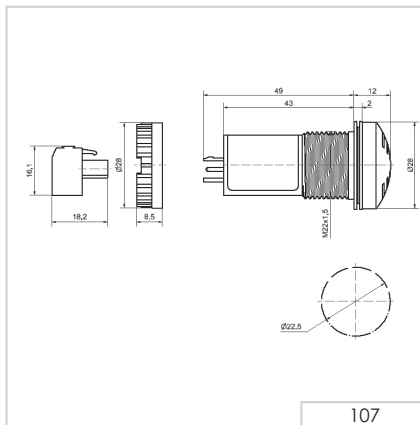

High protection rating IP 65 for use in arduous conditions

107 0X0 7X
107 0X0 68

CE

EAC

UK
CA

cULus

IP 65

+50°C
-20°C

10 cm
80 dB

109 Electronic Installation Buzzer



Surface housing (accessory)



Surface housing (triple) for 2 beacons and 1 audible element (not included in assembly)

① TECHNICAL SPECIFICATIONS/ORDER SPECIFICATIONS:

Dimensions (Ø x Height):	52 mm x 35 mm (Protrusion from panel)		
Housing:	PC/ABS-Blend; Cap: PC		
Tone frequency:	c. 2,100 Hz		
Tone type:	Continuous tone or pulse tone with approx. 1 Hz		
Fixing:	Installation mounting for Ø 22.5 mm (M22) with anti-twist device		
Connection:	Connector plug with screw terminal max. 1.5 mm ²		
Life duration:	> 5,000 hrs		
Voltage:	24 V AC/DC	115 V AC/DC	230 V AC
Current consumption:	25 mA	25 mA	25 mA
Continuous tone	109 000 75	109 000 77	109 000 68
Pulse tone	109 010 75	109 010 77	109 010 68

✂ ACCESSORIES:

Bracket with protective cap (IP54), only 24 V	975 109 01
Single surface housing	975 109 02
Double surface housing	975 109 03
Triple surface housing	975 109 04

Assembly comprises of only the surface housing. Beacons 800-802 or 815-817 have to be ordered additionally.

↔ TECHNICAL DIAGRAM:

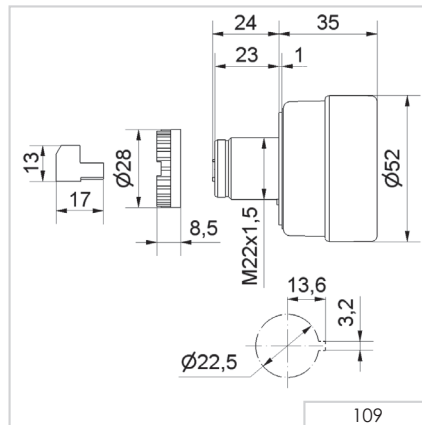

110 Electronic Installation Multi-Tone Sounder



Surface housing (accessory)



Bracket (accessory)

① TECHNICAL SPECIFICATIONS/ORDER SPECIFICATIONS:

Dimensions (Ø x Height):	72 mm x 40 mm (Protrusion from panel)		
Housing:	PC/ABS-Blend; Cap: PC		
Sound output:	Max. 100 dB (sound output is adjustable on rear side when mounted)		
Fixing:	Installation mounting for Ø 22.5 mm (M22) with anti-twist device		
Connection:	Connector plug with screw terminal max. 1.5 mm ²		
Life duration:	> 5,000 hrs		
Voltage:	24 V AC/DC	115 V AC	230 V AC
Current consumption:	80 mA	40 mA	40 mA
Order No.:	110 000 75	110 000 67	110 000 68

♪ TONE TYPES AND FREQUENCIES:

8 tones selectable on rear side of the housing

	position 0		1.6 kHz	86 dB (A)
	position 1		1.6 kHz	86 dB (A)
	position 2		1.6 kHz	86 dB (A)
	position 3		1.6 kHz	88 dB (A)
	position 4		3.4 kHz	90 dB (A)
	position 5		3.4 kHz	100 dB (A)
	position 6		3.4 kHz	96 dB (A)
	position 7		3.4 kHz	100 dB (A)

✂ ACCESSORIES:

Bracket with protective cap (IP 54)	975 109 01
Surface housing IP 65 (single)	975 109 02
Surface housing IP 65 (double) for 1 installation beacon and 1 Installation siren	975 109 03
Surface housing IP 65 (triple) for 2 installation beacons and 1 Installation siren	975 109 04

↔ TECHNICAL DIAGRAM:

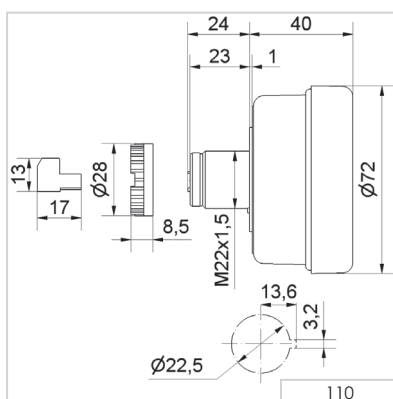

114 Electronic Installation Buzzer

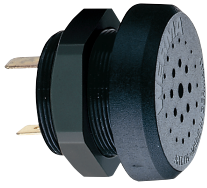

TECHNICAL SPECIFICATIONS/ORDER SPECIFICATIONS:

Dimensions (Ø x Height):	42.5 mm x 10 mm (Protrusion from panel)
Housing:	PC/ABS-Blend; Nut: PA fibreglass, high-impact
Connection:	Spades 6.3 x 0.8 mm, finger proof model according to BGV A2, when used with insulated spades
Tone frequency:	c. 2,400 Hz
Fixing:	Installation mounting for Ø 30.5 mm (M30)
Voltage:	24 V DC (12-30 V)
Current consumption:	20 mA
Order No.:	114 068 15

TECHNICAL DIAGRAM:

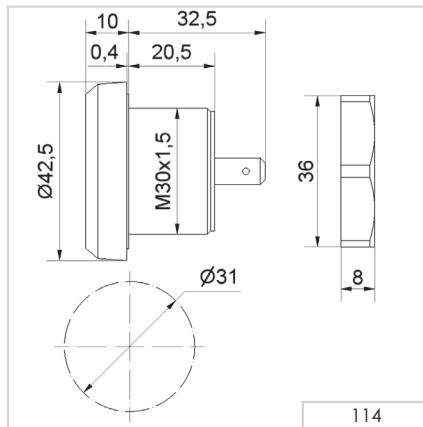

118/119 Electronic Installation Buzzer



Cap

① TECHNICAL SPECIFICATIONS/ORDER SPECIFICATIONS:

Dimensions (Ø x Height):	43 mm x 49 mm (Protrusion from panel)				
Housing:	PC/ABS-Blend				
Connection:	Spades 6.3 x 0.8 mm, finger proof model according to BGV A2, when used with insulated spades				
Tone frequency:	c. 2,400 Hz				
Tone type:	Type 118 Continuous tone Type 119 Continuous tone and pulse tone, c. 1 Hz, selectable via plug-in terminal Version with 3 tones: 2.7 kHz, 270 Hz, 337 Hz				
Fixing:	Installation mounting for Ø 28.5 mm (M28)				
Voltage:	12 V DC	24 V AC/DC	48 V AC/DC	115 V AC/DC	230 V AC
Current consumption:	20 mA	20 mA	20 mA	20 mA	20 mA
Continuous tone	118 068 14	118 068 15	118 068 26	118 068 27	118 068 28
Continuous/pulse tone	-	119 068 15	119 068 26	119 068 27	119 068 28
Voltage:	24 V DC (9-29 V DC)				
Current consumption:	< 30 mA (Tone 1)				
3 tones		119 004 55			

✦ ACCESSORIES:

Cap	975 118 00
-----	-------------------

↔ TECHNICAL DIAGRAM:

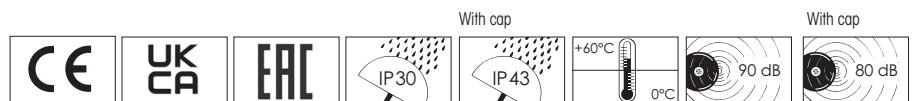
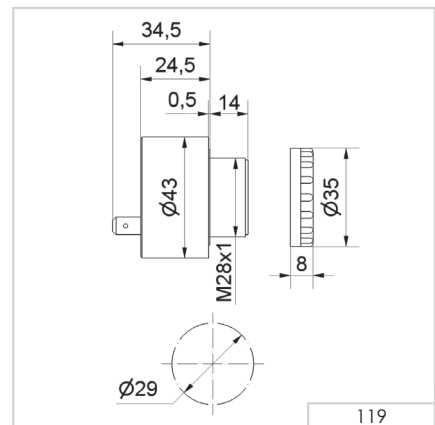
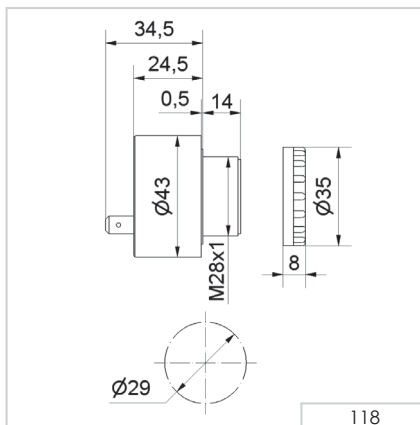

EvoSIGNAL - Horns & Sirens



Mini

Midi



EvoSIGNAL - Horns & Sirens

Your benefits

The type of audible signals used depends on the application and the environment. With EvoSIGNAL, finding the right signal device has never been so easy: almost all applications are covered by only two sizes with specific mounting adapters. The new modular, simple and clear standard solution. EvoSIGNAL is one of a kind.

- Simple and easy to use: Number of different articles reduced to 20% whilst retaining a full range
- Adaptable: Adjustable volume, 10 tones available with Midi range
- Poka Yoke: Simple and intuitive installation - incorrect installation is impossible

Typical applications

Signal faults and statuses on machines and equipment, in building services engineering and for electric gates and entry access systems. All products are ideal for demanding indoor and outdoor applications.

- Mini – in installation sites with limited space
- Midi – signalling over medium distances (10–30 m)

Installation options

- Base mounting
- M22/PG 29 single-hole mounting
- Tube mounting
- Bracket mounting

Features

- Push fit connection terminals: Simple and permanently secure connection
- Fully compatible: Easy replacement of previous products
- Best-in-class equipment: Powerful, extremely robust (IP66), tamper-proof



EvoSIGNAL Mini - Horns & Sirens

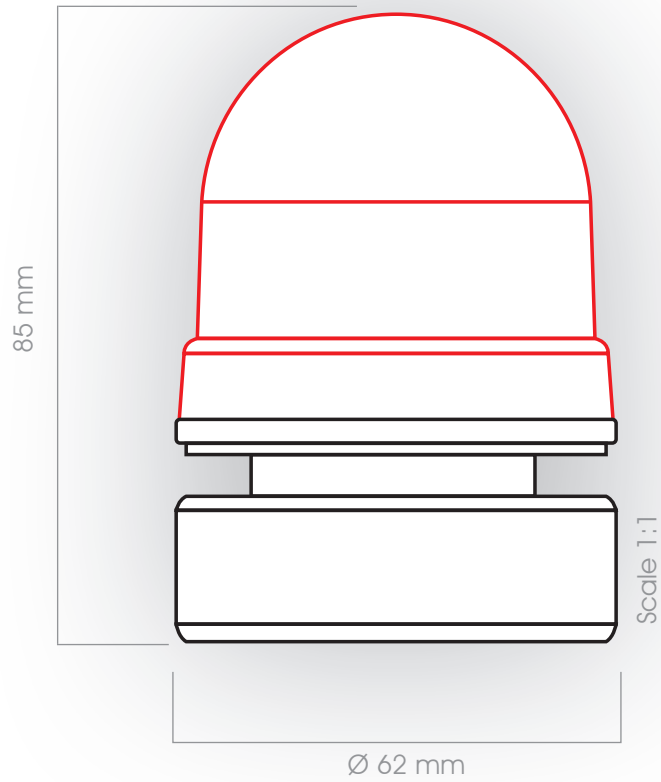

3
Horns & Sirens



6
Mounting adapter



Quick-Finder EvoSIGNAL Mini - Horns & Sirens



12 V AC/DC

160 700 74

24 V AC/DC

160 700 75

115-230 V AC

160 700 60

+ Mounting adapter (compulsory!)

Base mounting



Order no.
260 700 01

Installation
mounting M22



Order no.
260 700 03

Installation
mounting PG 29



Order no.
260 700 04

Tube mounting



Order no.
260 700 05

Bracket mounting
with cable gland

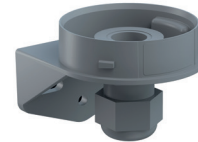

Order no.
260 700 06

Bracket mounting

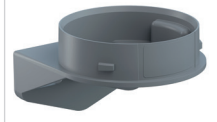

Order no.
260 700 07

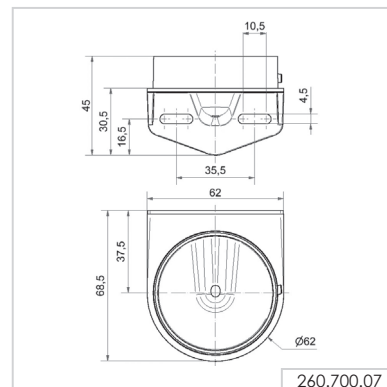
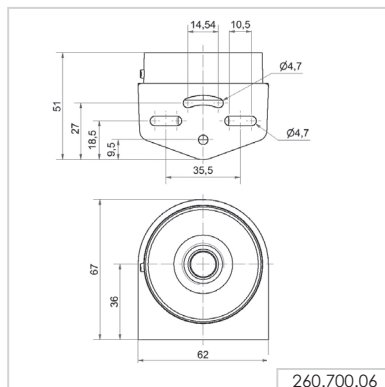
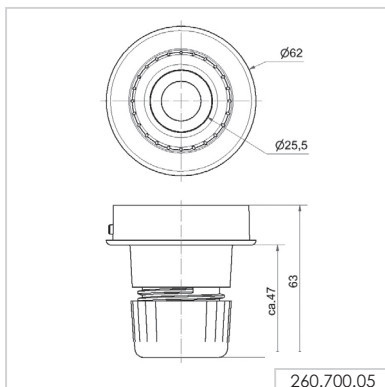
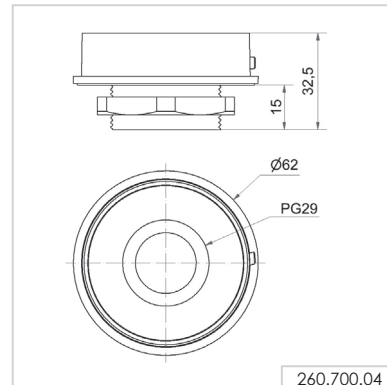
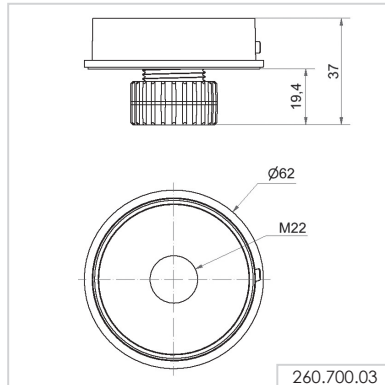
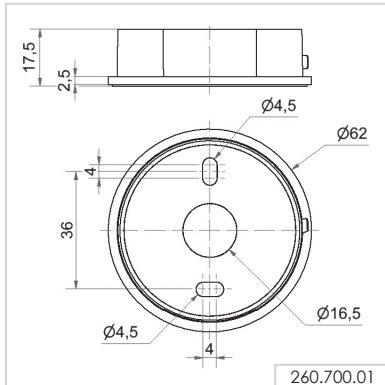

EvoSIGNAL Mini - Horns & Sirens



Bracket mounting with cable gland

① TECHNICAL SPECIFICATIONS/ORDER SPECIFICATIONS:

Dimensions (Ø x Height):	62 mm x 85 mm		
Housing:	PC/ABS		
Lens:	PC, grey		
Fixing:	Base/Tube/Wall and Inatallation mounting		
Cable entry:	Cable diameter 8-12 mm		
Connection:	Push-In terminal max. 1.5 mm ²		
Tone type:	Pulse or Permanent tone		
Voltage:	12 V AC/DC	24 V AC/DC	115-230 V AC
Current consumption:	≤ 30 mA	≤ 40 mA	≤ 30 mA
Order no.	160 700 74	160 700 75	160 700 60

✂ ACCESSORIES:

Base mounting	260 700 01
Installation mounting M22	260 700 03
Installation mounting PG 29	260 700 04
Tube mounting	260 700 05
Bracket mounting with cable gland	260 700 06
Bracket mounting	260 700 07

← TECHNICAL DIAGRAM:

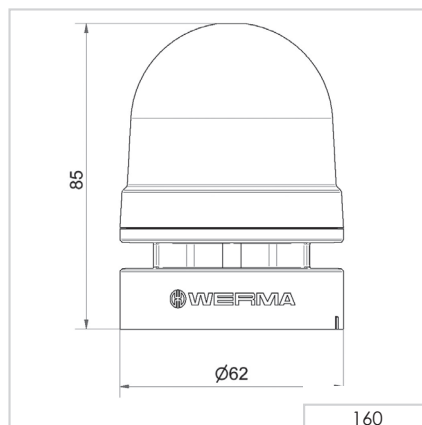

EvoSIGNAL Midi - Horns & Sirens

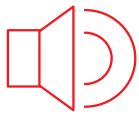
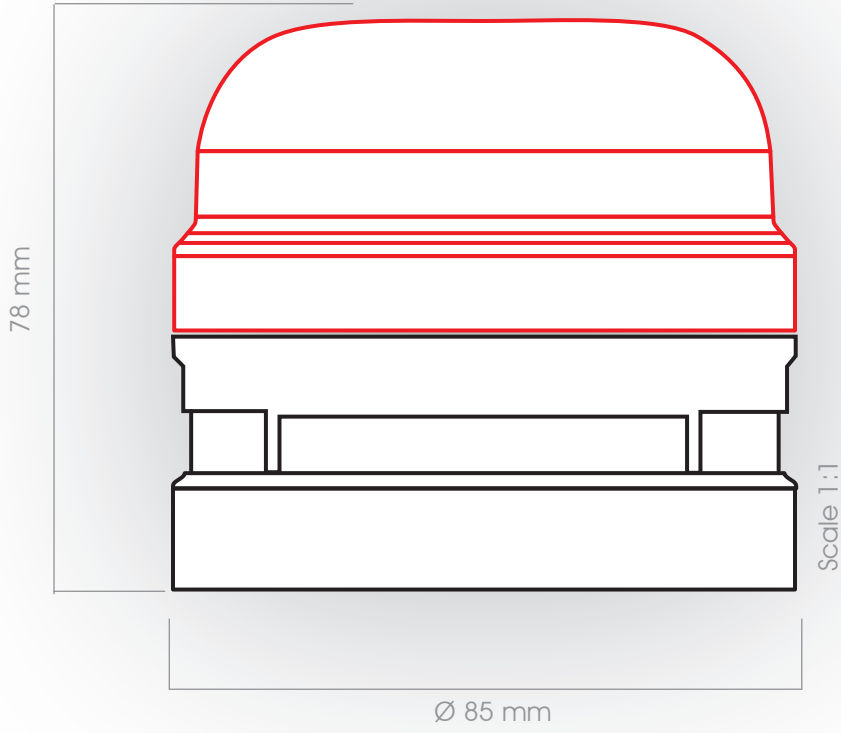

2
Horns & Sirens



6
Mounting adapter

Quick-Finder EvoSIGNAL Midi - Horns & Sirens

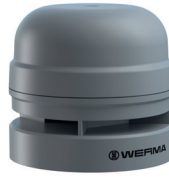

12/24 V AC/DC

161 700 70

115-230 V AC

161 700 60

+ Mounting adapter (compulsory!)

Base mounting

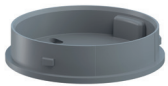

Order no.
261 700 01

Base mounting
with cable gland

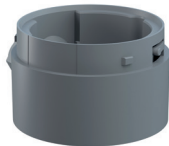

Order no.
261 700 02

Tube mounting



Order no.
261 700 05

Bracket mounting
with cable gland

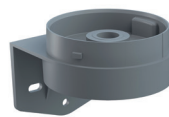

Order no.
261 700 06

Bracket mounting

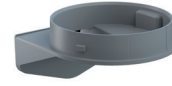

Order no.
261 700 07

Horn



Order no.
261 700 03

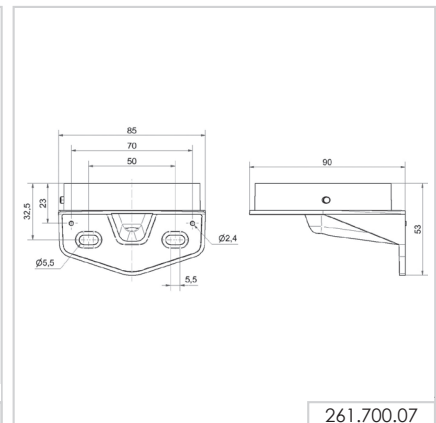
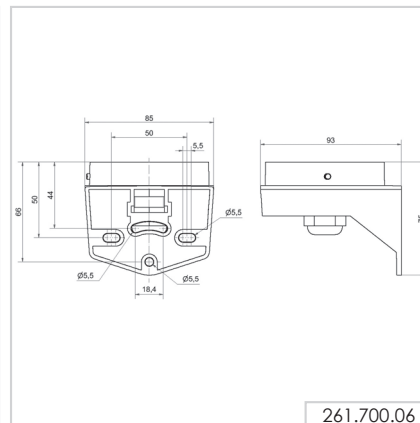
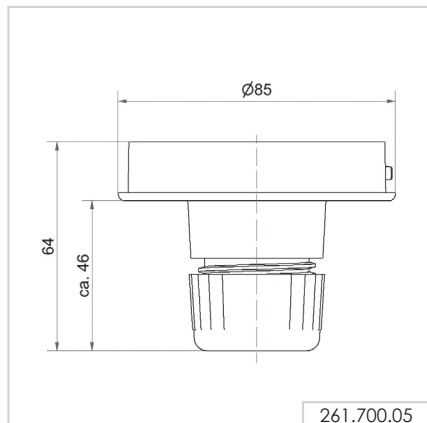
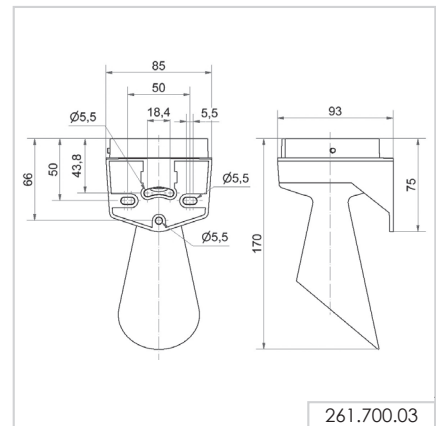
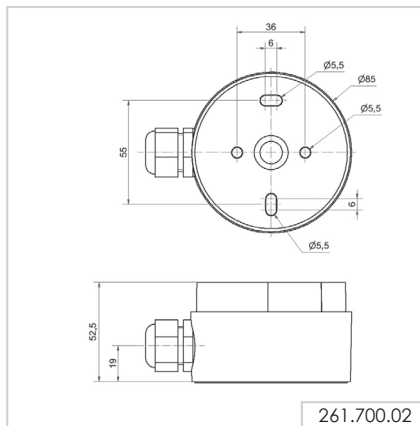
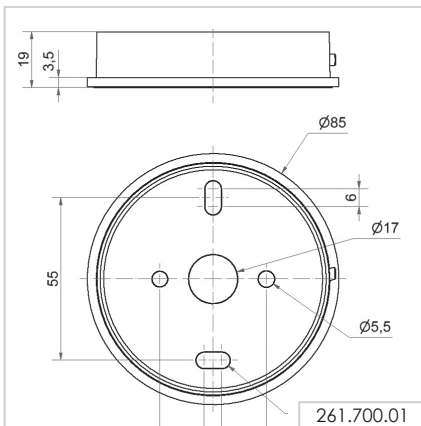

EvoSIGNAL Midi - Horns & Sirens



Base mounting



Tube mounting

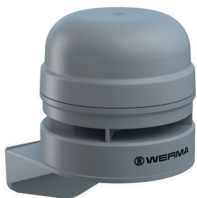

Bracket mounting

① TECHNICAL SPECIFICATIONS/ORDER SPECIFICATIONS

Dimensions (Ø x Height): 85 mm x 78 mm		
Housing:	PC/ABS	
Lens:	PC, grey	
Fixing:	Base/Tube/Wall mounting	
Cable entry:	Cable diameter 8-12 mm	
Connection:	Push-In terminal max. 1.5 mm ²	
Tone type:	Multi-tone	
Tone frequency:	3300 Hz	
<hr/>		
Voltage:	12/24 V AC/DC	115-230 V AC
Current consumption:	≤ 175 mA	≤ 105 mA
Order no.	161 700 70	161 700 60

♪ TONE TYPES AND FREQUENCIES

10 selectable tones and adjustable sound output

Tone	Tone type
0	Horn tone (ca. 110 Hz), max. 107 dB(A)
1	Continuous tone (ca. 3.3 kHz), max. 106 dB(A)
2	Pulse tone 1 Hz (ca. 3.3 kHz), max. 110 dB(A)
3	Whistle tone 20 Hz (ca. 3.3 kHz), max. 110 dB(A)
4	800 – 970 Hz rising @ 1 Hz, max. 95 dB(A)
5	2400 - 2850 Hz rising @ 7 Hz, max. 99 dB(A)
6	1200 – 500 Hz falling @ 1 Hz, max. 101 dB(A)
7	Alternating tone 800 Hz / 1200 Hz @ 1 Hz, max. 100 dB(A)
8	Sweep-Tone 2100 – 4100 Hz @ 0.5 Hz, max. 110 dB(A)
9	Continuous tone (c. 700 Hz), max. 97 dB(A)

✂ ACCESSORIES:

Base mounting	261 700 01
Base mounting with cable gland	261 700 02
Tube mounting	261 700 05
Bracket mounting with cable gland	261 700 06
Bracket mounting	261 700 07
Horn	261 700 03

↔ TECHNICAL DIAGRAM

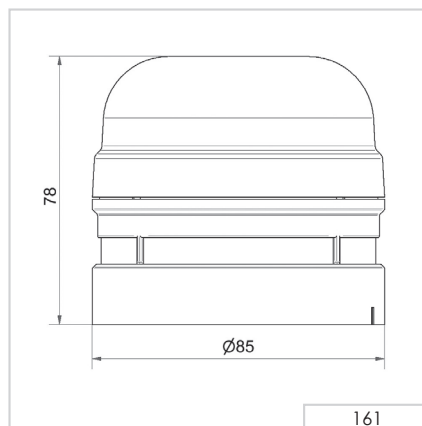

Horns and Sirens

Your benefits

The loud Horns, Sounders and Sirens from WERMA provide safety and security by delivering reliable audible warning when faults occur over longer distances or in noisy environments.

- Quick and easy installation
- Tamper-proof when installed
- Ideal for noisy environments

Typical applications

Fault signalling

- On machine controllers and on large equipment
- In building service systems (e.g. gas alarm)
- Alarm in the event of overload (e.g. mobile cranes)

Installation options

- Wall mounting

Features

- 574/575 series with ten times longer life duration compared to electromechanical versions
- Up to 8 tones for signalling different statuses

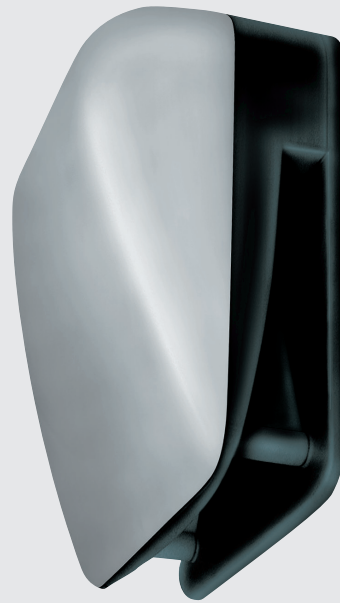



123 Electronic Siren

① TECHNICAL SPECIFICATIONS/ORDER SPECIFICATIONS:

Dimensions (L x H x W):	54 mm x 67 mm x 67 mm	
Housing:	ABS	
Tone frequency:	2.5 / 3.5 kHz	
Tone type:	Alternating	
Connection:	2 wires, c. 450 mm long	
Fixing:	Metal bracket	
Voltage:	12 V DC	24 V DC
Current consumption:	100 mA	100 mA
Order No.:	123 100 54	123 200 55

↔ TECHNICAL DIAGRAM:

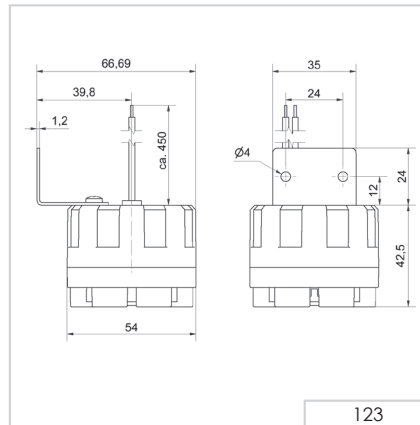

126 Electronic Multi-Tone Sounder



① TECHNICAL SPECIFICATIONS/ORDER SPECIFICATIONS:

Dimensions (L x H x W):	70 mm x 79.5 mm x 77 mm
Housing:	PC/ABS-Blend
Tone types and frequencies:	4 selectable tones adjustable Continuous tone: c. 2,700 Hz Continuous tone: c. 530 Hz Bell: c. 2,700 Hz (pulse 20 Hz) Pulse tone: c. 2,700 Hz (pulse 1 Hz)
Connection:	Screw terminal 0.5 - 1.5 mm ²
Cable entry:	Cable diameter max. 9 mm
Fixing:	Wall mounting, Sound outlet facing downwards
Voltage:	12-24 V DC
Current consumption:	80 mA
Order No.:	126 052 15

↔ TECHNICAL DIAGRAM:

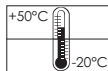
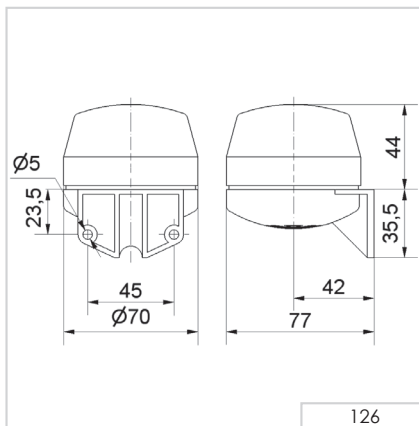



570 Electromechanical Signal Horn

① TECHNICAL SPECIFICATIONS/ORDER SPECIFICATIONS:

Dimensions (L x H x W):	148 mm x 350 mm x 152 mm			
Housing:	PC/ABS-Blend			
Connection:	Screw terminal 0.5 - 2.5 mm ²			
Fixing:	Wall mounting, Sound outlet facing downwards			
Voltage:	24 V AC (50 Hz)	42-48 V AC (50/60 Hz)	115 V AC (50/60 Hz)	230 V AC (50 Hz)
Current consumpt.:	500 mA	250 mA	200 mA	70 mA
Order No.:	570 052 65	570 052 66	570 052 67	570 052 68

Pulse tone (AC)

Voltage:				230 V AC (50 Hz)
Current consumpt.:				≤ 70 mA
Order No.:				570 100 68

Continuous tone (DC)

Voltage:	24 V DC		115 V DC	230 V DC
Current consumpt.:	350 mA		150 mA	100 mA
Order No.:	570 052 55		570 052 57	570 052 58

Further voltages on request.

↔ TECHNICAL DIAGRAM:

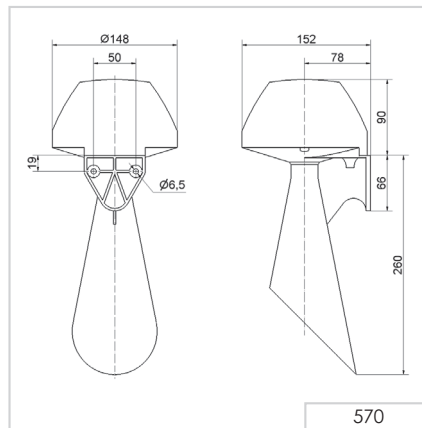

573 Electromechanical Signal Horn



① TECHNICAL SPECIFICATIONS/ORDER SPECIFICATIONS:

Dimensions (L x H x W):	104 mm x 232 mm x 232 mm				
Fixing dimensions (W x H):	130 mm x 160 mm				
Housing:	PC/ABS-Blend				
Connection:	Screw terminal 0.5 - 2.5 mm ²				
Cable entry:	Cable gland M16 x 1.5 mm Cable diameter 5-10 mm				
Fixing:	Wall mounting, Sound outlet facing downwards				
Voltage:	24 V DC	24 V AC (50 Hz)	42-48 V AC (50/60 Hz)	115 V AC (50/60 Hz)	230 V AC (50 Hz)
Current consumption:	350 mA	500 mA	250 mA	200 mA	70 mA
Order No.:	573 000 55	573 000 65	573 000 66	573 000 67	573 000 68

↔ TECHNICAL DIAGRAM:

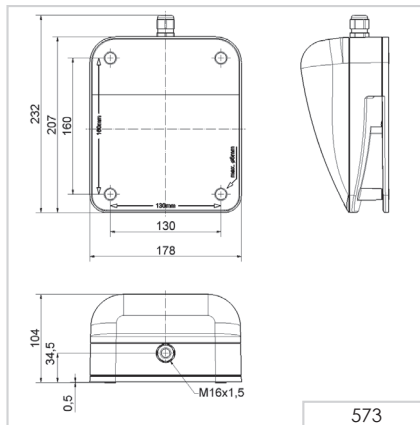

574 Electronic Signal Horn



① TECHNICAL SPECIFICATIONS/ORDER SPECIFICATIONS:

Dimensions (Ø x Height):	134 mm x 340 mm		
Housing:	PC/ABS-Blend, grey		
Fixing:	Wall mounting, integrated mounting bracket		
Installation position:	Sound outlet facing downwards		
Connection:	Screw terminal 0.5 - 1.5 mm ²		
Cable entry:	Cable diameter max. 11 mm		
Tone frequency:	C. 110 Hz		
Life duration:	Up to 5,000 hrs		
Voltage:	24 V AC/DC	12-48 V AC/DC*	115-230 V AC
Current consumption:	55 mA	210 mA	30 mA
Order No.:	574 000 75	574 000 70	574 000 60

* Current consumption at 10 V / 115 V

↔ TECHNICAL DIAGRAM:

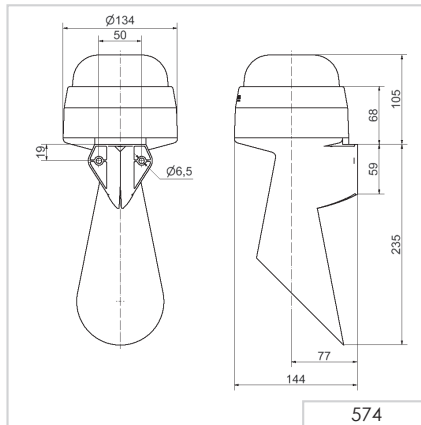

575 Electronic Signal Horn



Quick and simple wall mounting without additional accessories with the integrated mounting bracket



① TECHNICAL SPECIFICATIONS/ORDER SPECIFICATIONS:

Dimensions (L x H x W):	134 mm x 169 mm x 144 mm		
Housing:	PC/ABS-Blend, grey		
Fixing:	Wall mounting, integrated mounting bracket		
Installation position:	Sound outlet facing downwards		
Connection:	Screw terminal 0.5 - 1.5 mm ²		
Cable entry:	Cable diameter max. 11 mm		
Tone frequency:	C, 110 Hz		
Life duration:	Up to 5,000 hrs		
Voltage:	24 V AC/DC	10-48 V AC/DC*	115-230 V AC
Current consumption:	55 mA	210 mA	30 mA
Order No.:	575 000 75	575 000 70	575 000 60

* Current consumption at 10 V / 115 V

↔ TECHNICAL DIAGRAM:

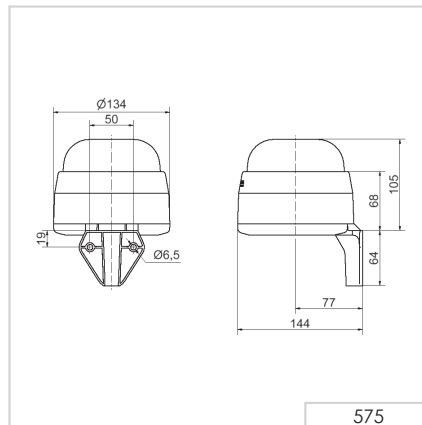

adjustable

--	--	--	--	--	--	--

Design Multi-Tone Sounder

Your benefits

WERMA Design Multi-Tone Sounders provide safety and security by providing an audible warning in applications with greater aesthetic requirements. The innovative housing design makes for simple mounting in many diverse applications.

- Ideal signalling effect over great distances
- Many application options with up to 32 tones available
- Up to 3 tones can be externally triggered for the escalation of signals
- Includes standardised tones (including those used in fire alarms)

Typical applications

- Signalling faults or alarms in the event of danger
- in building service systems
- on machinery and equipment

Installation options

- Wall mounting
- Base mounting
- Ceiling mounting

Features

- Up to 32 tones (standardised according to various standards and guidelines)
- Multi-voltage versions allow multiple applications with a single device



140 Multi-Tone Sounder



① TECHNICAL SPECIFICATIONS/ORDER SPECIFICATIONS:

Dimensions (Ø x Height):	100 mm x 110 mm
Housing:	PC/ABS-Blend
Connection:	Screw terminal max. 2.5 mm ²
Cable entry:	Cable gland M20 x 1.5 mm Cable gland not included in assembly
Tone types and frequencies:	Selectable via DIP switch, see table page 180
Installation position:	Sound outlet not facing upwards
Voltage:	9-28 V DC
Current consumption:	≤ 120 mA
red	140 150 50
white	140 950 50
Voltage:	110-240 V AC
Current consumption:	≤ 40 mA
red	140 150 60
white	140 950 60

✂ ACCESSORIES:

Cable gland M20 x 1.5 mm	975 444 01
--------------------------	-------------------

↔ TECHNICAL DIAGRAM:

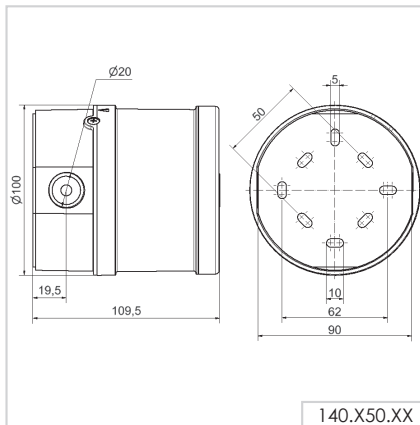

140 Tone table

The 140 Multi-Tone Sounder offers a large choice of internationally recognised signal tones for the widest spectrum of applications. The low voltage version allows two tones to be triggered externally. Selectable via DIP switch.

♪ TONE TYPES AND FREQUENCIES:

Tone 1 No.	Tone type	Description	Sound output (dBA)		Tone 2 Low voltage
			(12 V)	(24 V)	
1	alternating 800/970 Hz in 2 Hz stroke	BS 5839-1: 2002	101	105	14
2	rising 800/970 Hz in 7 Hz stroke		103	107	14
3	rising 800/970 Hz in 1 Hz stroke	BS 5839-1: 2002; VdS tested	104	108	14
4	continuous 2,850 Hz		110	115	14
5	rising 2,400-2,850 Hz in 7 Hz stroke		108	114	4
6	rising 2,400-2,850 Hz in 1 Hz stroke		109	115	4
7	500-1,200 Hz rising in 3 sec., 0.5 sec OFF		100	104	14
8	falling 1,200-500 Hz in 1 Hz stroke	DIN 33404; VdS tested	99	104	14
9	alternating 2,400/2,850 Hz in 2 Hz stroke		108	115	4
10	pulse 970 Hz in 0.5 Hz stroke	Back-up-alarm BS 5839 Part 1 1988	98	105	14
11	alternating 800/970 Hz in 1 Hz stroke	BS5839 Part 1 1988	100	105	14
12	pulse 2,850 Hz in 0.5 Hz stroke		107	114	4
13	970 Hz pulse: 0.25 sec. ON / 1 sec. OFF		96	105	14
14	continuous 970 Hz	BS 5839-1: 2002	101	105	15
15	554 Hz/100 ms alternating 440 Hz/400 ms	French alarm signal AFNOR NFS 32 S 32-001	97	102	14
16	660 Hz pulse: 150 ms ON, 150 ms OFF	Swedish alarm signal	97	101	17
17	660 Hz pulse: 1.8 sec. ON, 1.8 sec. OFF	Swedish alarm signal	97	103	16
18	660 Hz pulse: 6.5 sec. ON, 13 sec. OFF	Swedish alarm signal	99	103	14
19	continuous 660 Hz	Swedish alarm signal	99	103	21
20	alternating 554/440 Hz in 0.5 Hz stroke		99	103	21
21	pulse 660 Hz in 1 Hz stroke	Swedish alarm signal	98	104	19
22	2,850 Hz pulse: 150 ms ON, 100 ms OFF	Pedestrian crossing GB	109	115	14
23	rising 800/970 Hz in 50 Hz stroke	Low frequency BS 5839 Part 1 1988	101	106	14
24	rising 2,400-2,850 Hz in 50 Hz stroke	High frequency	106	112	4
25	970 Hz pulse: 3 x 500 ms ON, 500 ms OFF, Pause 1.5 sec.	ISO 8201 Low frequency: Evacuation	101	105	26
26	2,850 Hz pulse: 3 x 500 ms ON, 500 ms OFF, Pause 1.5 sec.	ISO 8201 High frequency	109	115	25
27	970/800 Hz alternating: 1.5 s ON, 0.5 s OFF		96	105	17
28	alternating 800/970 Hz in 2 Hz stroke	FP 1063.1 -Telecoms/BS 5839-1: 2002	99	105	10
29	alternating 988/645 Hz in 2 Hz stroke		99	104	988 Hz cont. tone
30	alternating 510/610 Hz in 2 Hz stroke		97	102	510 Hz cont. tone
31	falling 1,200-300 Hz in 1 Hz stroke		99	104	13
32	alternating 510/610 Hz in 1 Hz stroke		97	102	510 Hz cont. tone



144 Multi-Tone Sounder



Base Mounting



Wall mounting

① TECHNICAL SPECIFICATIONS/ORDER SPECIFICATIONS:			
Dimensions (L x H x W):	109 mm x 113 mm x 150 mm		
Housing:	PC/ABS-Blend		
Connection:	24 V: Screw terminal 0.5 - 1.5 mm ² 115/230 V: CAGE CLAMP®		
Cable entry:	Membrane for cable diameter max. 13 mm		
Fixing:	Wall, base and ceiling mounting		
Tone types and frequencies:	Selectable via DIP switch, see table on page 182		
Voltage:	24 V AC/DC	115 V AC	230 V AC
Current consumption:	200 mA	55 mA	30 mA
Order No.:	144 000 75	144 000 67	144 000 68

✂ ACCESSORIES:	
Cable gland M20 x 1.5 mm (for cable strain relief)	975 444 01
Protection rating IP 65 is provided even without cable gland	

↔ TECHNICAL DIAGRAM:

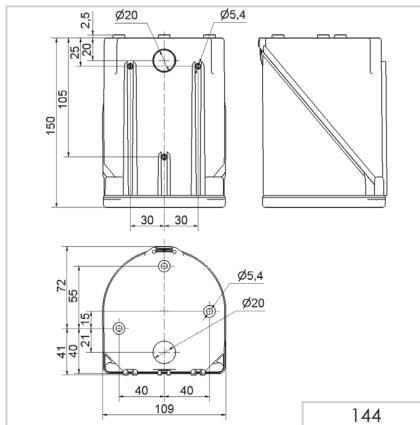

CE	UK CA	EAC	IP 65	+50°C -30°C	(A) 110 dB	(C) 114 dB	32	24 V	PLC
----	----------	-----	-------	----------------	------------	------------	----	------	-----



144 Tone table

The 144 Multi-Tone Sounder offers a large choice of internationally recognised signal tones for the widest spectrum of applications. 3 tones can be triggered externally.

♫ TONE TYPES AND FREQUENCIES:

Tone 1	Tone type	Frequency (Hz)	Description	Use	Tone 2	Tone 3	Output (dB)
1	continuous	200		BS 5839-1:2002	440 Hz cont.	554 Hz cont.	97
2	rising	800 & 970	7 Hz		14	800 Hz cont.	102
3	rising	800 & 970	1 Hz		14	800 Hz cont.	103
4	continuous	2850	3 s, then 0.5 s OFF (then repeat)		14	9	104
5	rising	2400 - 2850	7 Hz		4	2400 Hz cont.	109
6	rising	2400 - 2850	1 Hz		4	2400 Hz cont.	110
7	rising	500 - 1200	3 s, then 0.5 s OFF (then repeat)		14	8	106
8	falling	1200 - 500	1 Hz	DIN 33404-3	14	7	104
9	alternating	2400 & 2850	2 Hz		4	2400 Hz cont.	111
10	pulse	970	0.5 Hz (1 s On/1 s Off)	BS 5839 Part 1 1988	14	800 Hz cont.	101
11	alternating	800 & 970	1 Hz	BS 5839 Part 1 1988	14	800 Hz cont.	105
12	pulse	2850	0.5 Hz		4	22	104
13	pulse	970		0,25 s On/1 s Off	14	800 Hz cont.	98
14	continuous	970		BS 5839-1:2002 PFEER - Toxic gas	10	8	102
15	alternating	554 & 440		France NFS	14	800 Hz cont.	101
16	pulse	660	150 ms On/150 ms Off	Swedish	16	14	96
17	pulse	660	1.8 s On/1.8 s Off	Swedish	17	14	98
18	pulse	660	6.5 s On/13 s Off	Swedish	18	14	98
19	continuous	660		Swedish	19	31	98
20	alternating	554 & 440	0.5 Hz		20	19	102
21	pulse	660	1 Hz	Swedish	21	4	97
22	pulse	2850	150 ms On/100 ms Off	GB	14	4	104
23	rising	800 - 970	50 Hz (low)	BS 5839 Part 1 1988	14	800 Hz cont.	102
24	rising	2400 - 2850	50 Hz (high)		4	2400 Hz cont.	109
25	pulse	970	3 x 500 ms ON/500 ms OFF / 1.5 s silence, then repeat (low)	ISO 8201 US Temporal	26	14	101
26	pulse	2850	3 x 500 ms ON/500 ms OFF / 1.5 s silence, then repeat (high)	ISO 8201 US Temporal	25	4	104
27	continuous	4000			27	6	92
28	rising	2000 - 2850	7 Hz		2000 Hz cont.	4	111
29	alternating	988 & 645	2 Hz		988 Hz cont.	645 Hz cont.	102
30	alternating	510 & 610	2 Hz		510 Hz cont.	610 Hz cont.	102
31	alternating	800 & 970	2 Hz	5839-1:2002	800 cont.	14	105
32	alternating	800 & 1200	1 Hz		800 cont.	1200 Hz cont.	105



Vocal alarm

Your benefits

This extremely loud Vocal Alarm provides the ability to play application-specific audio files in order to produce clear and targeted instructions. It is particularly suitable for large assembly facilities and can address defined groups of people (for example, a particular work unit) in a targeted manner.

- Reliable alarm output over long distances or in noisy environments
- Easy to adjust to local conditions
- Excellent audio and sound quality for optimum clarity of signalling
- Completely flexible; select the audio file yourself

Typical applications

Signalling faults or issuing specific instructions

- For areas with high ambient noise levels
- In production and assembly environments

Installation options

- Wall mounting

Features

- Plays customer-specific audio files (sounds, melodies and your own recorded messages)
- 15 files can be played, or a sequence with a maximum of 50 files
- Simple USB data transfer
- Sound output can be externally triggered up to 110 dB



154 Vocal alarm



Vocal alarm 154

① TECHNICAL SPECIFICATIONS/ORDER SPECIFICATIONS:

Dimensions (L x H x W):	111 mm x 98 mm x 111 mm
Housing:	PP-GF, PC/ABS Blend
Sound output:	Adjustable, up to 110 dB
File Transfer:	Via USB connection and provided software
Possible data format:	mp3 and wav files
Number of sequences:	15 files can be remotely triggered or one sequence with max. 50 files
Suitable for:	Windows®, System requirements - see Handbook
Assembly:	Vocal alarm , USB connection cable and software
Voltage:	24 V DC
Current consumption:	< 500 mA Low Power < 1500 mA High Power
Order No.:	154 000 55

↔ TECHNICAL DIAGRAM:

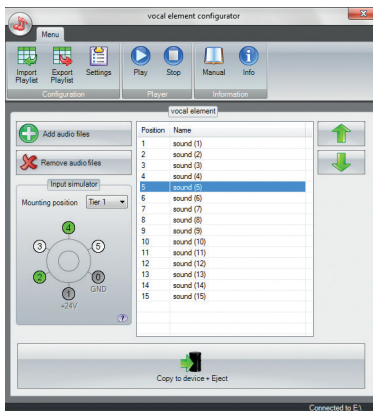
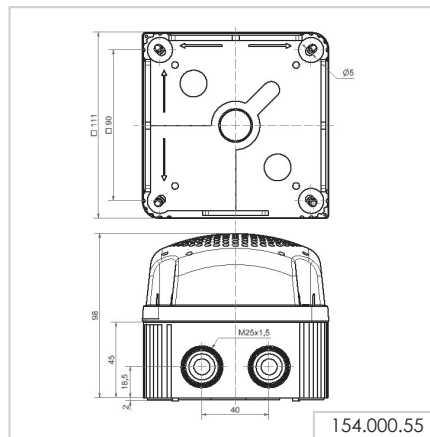

User-friendly software ensures easy transfer of audio files and simple operation



Heavy Duty Multi-Tone Sounder

Your benefits

The robust housings of WERMA Heavy Duty Multi-Tone Sounders are particularly well-suited for use in public areas or in harsh industrial environments. Versions with an aluminium housing and separate certification (German Lloyd) are available for marine applications.

- Ideal in extremely noisy environments and over long distances
- Many application options with up to 42 tones
- Up to 3 tones can be externally triggered for the escalation of signals
- Includes standardised tones (including those used in fire alarms)

Typical applications

Signalling of faults and alarms

- outdoors in extreme conditions
- in larger industrial plants
- in maritime applications

Installation options

- Wall mounting

Features

- High protection rating up to IP67
- Multi-voltage versions allow multiple applications with a single device

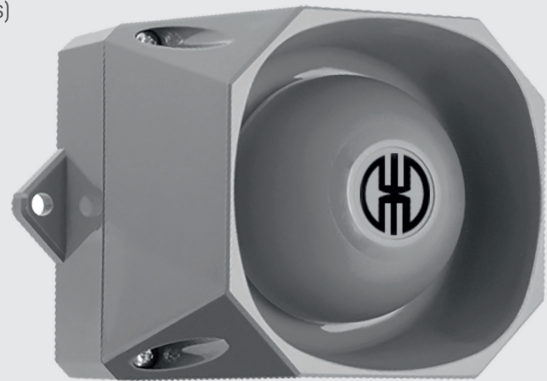



129 Electronic Multi-Tone Sounder (110 dB)



① TECHNICAL SPECIFICATIONS/ORDER SPECIFICATIONS:

Dimensions (L x H x W):	143 mm x 161 mm x 161 mm		
Housing:	Die-cast aluminium		
Connection:	Screw terminal 0.5 - 2.5 mm ²		
Cable entry:	Cable gland M20 x 1.5 mm Cable diameter 8-12 mm		
Tone types and frequencies:	Selectable via DIP switch, see table page 187		
Voltage:	24 V DC	115 V AC	230 V AC
Current consumption:	400 mA	120 mA	60 mA
Order No.:	129 052 55	129 052 67	129 052 68

↔ TECHNICAL DIAGRAM:

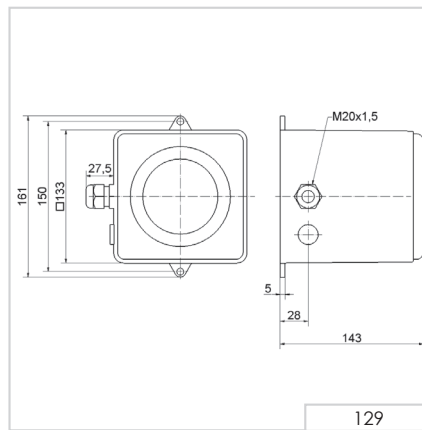

129 Tone table

The 129 Multi-Tone Sounder offers a large choice of internationally recognised signal tones for the widest spectrum of applications.

🎵 TONE TYPES AND FREQUENCIES:		
Tone 1+2 No.	Tone type	Description
1	falling 1,200-500 Hz in 1 Hz stroke	DIN 33404
2	950 Hz pulse: 3 x 500 ms ON, 500 ms OFF, Pause 1.5 sec.	ISO 8201
3	alternating 825 Hz/1,025 Hz in 2 Hz stroke	
4	continuous 950 Hz	
5	950 Hz pulse: 1 sec. ON, 1 sec. OFF	
6	500-1,200 Hz rising and falling in 3 sec.	Siren
7	554 Hz/100 ms alternating 440 Hz/400 ms	French fire alarm signal AFNOR NFS 32 S 32-001
8	pulse 700 Hz: 150 ms ON, 150 ms OFF, cycle 1 Min.	
9	pulse 800 Hz: 4 ms ON, 4 ms OFF	
10	continuous 500 Hz	
11	continuous 725 Hz	
12	continuous 825 Hz	
13	continuous 1,250 Hz	
14	continuous 1,500 Hz	
15	pulse 500 Hz: 500 ms ON, 500 ms OFF	
16	pulse 825 Hz: 500 ms ON, 500 ms OFF	
17	pulse 725 Hz: 0.7 sec. ON, 0.3 sec. OFF	
18	pulse 800 Hz: 0.25 sec. ON, 1 sec. OFF	
19	alternating 800 Hz/1,000 Hz in 2 Hz stroke	
20	pulse 825 Hz: 2.5 sec. ON, 2.5 sec OFF x 7, then 7 sec. pulse	
21	pulse 950 Hz: 1 sec. ON, 1 sec. OFF, 3 sec. ON, 1 sec. OFF	
22	rising 500-1,200 Hz in 3 sec., 0.5 sec OFF	
23	rising 500-2,400 Hz in 3 sec.	
24	alternating 825 Hz/1,075 Hz in 1 Hz stroke	
25	alternating 500 Hz/900 Hz in 2 Hz stroke	
26	alternating 1,200 Hz/1,400 Hz in 25 Hz stroke	
27	rising 300-1,200 Hz in 3 sec.	
28	700-1,500 Hz rising and falling in 3 sec.	
29	rising 150-1,000 Hz in 10 sec., 40 sec. ON, falling in 10 sec.	
30	pulse 680 Hz: 0.875 sec. ON, 0.875 sec. OFF	
31	rising 1,400-1,600 Hz in 1 sec., falling in 0.5 sec.	



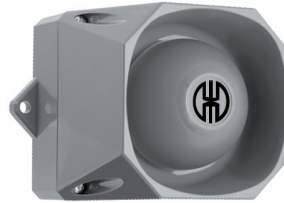

139 Electronic Multi-Tone Sounder (105 dB)

① TECHNICAL SPECIFICATIONS/ORDER SPECIFICATIONS:

Dimensions (L x H x W):	136 mm x 108 mm x 119 mm	
Housing:	ABS	
Connection:	Screw terminal 0.5 - 2.5 mm ²	
Cable entry:	Cable gland M20 x 1.5 mm (not included in assembly)	
Tone types and frequencies:	Selectable via DIP switch	
Voltage:	9-60 V DC	115/230 V AC
Current consumption:	15 mA (24V)	20 mA (230 V)
red	139 000 55	139 000 68
grey	139 100 55	139 100 68

✂ ACCESSORIES:

Cable gland M20 x 1.5 mm	975 444 01
--------------------------	-------------------

🎵 TONE TYPES AND FREQUENCIES:

For further details see www.werma.com.

↔ TECHNICAL DIAGRAM:

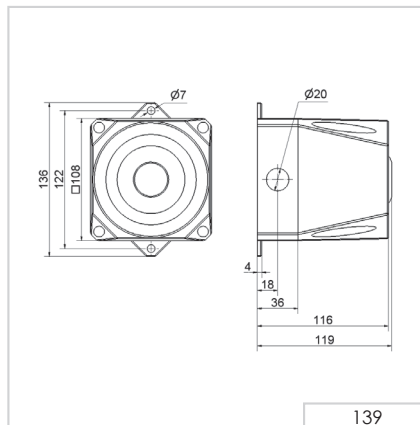

141 Electronic Multi-Tone Sounder (110 dB)



① TECHNICAL SPECIFICATIONS/ORDER SPECIFICATIONS:

Dimensions (L x H x W):	165 mm x 136 mm x 132 mm	
Housing:	PC/ABS-Blend	
Connection:	Screw terminal 0.5 - 2.5 mm ²	
Cable entry:	Cable gland M20 x 1.5 mm (not included in assembly)	
Tone types and frequencies:	Selectable via DIP switch	
Voltage:	9-60 V DC	115/230 V AC
Current consumption:	120 mA (24V)	22 mA (230 V)
red	141 000 55	141 000 68
grey	141 100 55	141 100 68

✂ ACCESSORIES:

Cable gland M20 x 1.5 mm	975 444 01
--------------------------	-------------------

♪ TONE TYPES AND FREQUENCIES:

For further details see www.werma.com.

↔ TECHNICAL DIAGRAM:

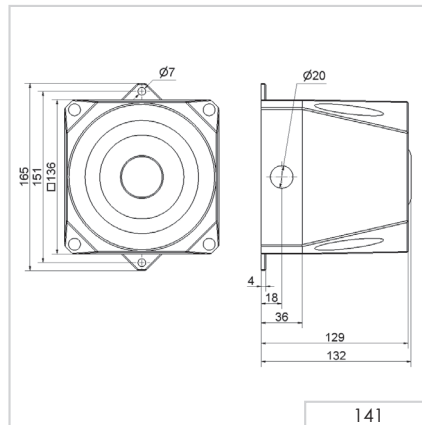

142 Electronic Multi-Tone Sounder (120 dB)



① TECHNICAL SPECIFICATIONS/ORDER SPECIFICATIONS:

Dimensions (L x H x W):	168 mm x 168 mm x 155 mm	
Housing:	PC/ABS-Blend	
Connection:	Screw terminal 0.5 - 2.5 mm ²	
Cable entry:	Cable gland M20 x 1.5 mm (not included in assembly)	
Tone types and frequencies:	Selectable via DIP switch, see table on page 193	
Voltage:	18-30 V DC	115/230 V AC
Current consumption:	450 mA	130 mA (115 V) / 65 mA (230 V)
red	142 000 55	142 000 68
grey	142 100 55	142 100 68

✂ ACCESSORIES:

Cable gland M20 x 1.5 mm	975 444 01
--------------------------	-------------------

↔ TECHNICAL DIAGRAM:

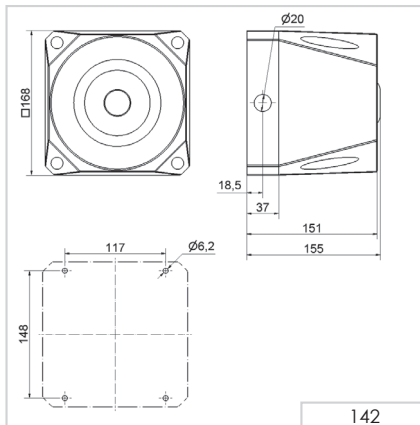

142 Tone table

The 142 Multi-Tone Sounder offers a large choice of internationally recognised signal tones for the widest spectrum of applications. The first two tones can be freely chosen. The third tone is paired with the second tone.

🎵 TONE TYPES AND FREQUENCIES:				
Tone 1+2 No.	Tone type	Description	Output (dBA)	Tone 3
1	alternating 800/970 Hz in 2 Hz stroke (250 ms-250 ms)		120	14
2	rising 800/970 Hz in 7 Hz stroke (7/s)		120	14
3	rising 800/970 Hz in 1 Hz stroke (1/s)		120	14
4	continuous 2,850 Hz		111	9
5	rising 2,400-2,850 Hz in 7 Hz stroke		109	4
6	rising 2,400-2,850 Hz in 1 Hz stroke		110	4
7	500-1,200 Hz rising in 3 sec., 0.5 sec. OFF	Slow Whoop Holland	119	14
8	falling 1,200-500 Hz in 1 Hz stroke	DIN/PFEER (PAPA), DIN 33404-3, VDS tested	119	14
9	alternating 2,400/2,850 Hz in 2 Hz stroke (250 ms-250 ms)		119	14
10	pulse 970 Hz in 0.5 Hz stroke (1 sec. ON / 1 sec. OFF)	PFEER Alarm	113	4
11	alternating 800/970 Hz in 1 Hz stroke (500 ms-500 ms)		117	14
12	pulse 2,850 Hz in 0.5 Hz stroke (1 sec. ON / 1 sec. OFF)		118	144
13	970 Hz pulse: 0.25 sec. ON / 1 sec. OFF		112	14
14	continuous 970 Hz	PFEER - Toxic gas	117	8
15	554 Hz/100 ms alternating 440 Hz/400 ms	French alarm signal AFNOR NFS 32 S 32-001	118	14
16	660 Hz pulse: 150 ms ON, 150 ms. OFF	Swedish alarm signal	115	14
17	660 Hz pulse: 1.8 sec. ON, 1.8 sec. OFF	Swedish alarm signal	114	14
18	660 Hz pulse: 6.5 sec. ON, 13 sec. OFF	Swedish alarm signal	115	14
19	continuous 660 Hz	Swedish alarm signal	116	1
20	alternating 554/440 Hz in 0.5 Hz stroke (1 sec. ON / 1 sec. OFF)	Swedish alarm signal	115	19
21	pulse 660 Hz in 1 Hz stroke (500 ms-500 ms)	Swedish alarm signal	115	4
22	pulse 2,850 Hz in 4 Hz stroke (150 ms ON / 100 ms OFF)		110	4
23	rising 800-970 Hz in 50 Hz stroke		117	14
24	rising 2,400-2,850 Hz in 50 Hz stroke		110	4
25	970 Hz pulse: 3 x 500 ms. ON, 500 ms OFF, break 1.5 sec.	ISO 8201 / US Temporal	118	14
26	2,850 Hz pulse: 3 x 500 ms. ON, 500 ms OFF, break 1.5 sec.	ISO 8201 / US Temporal	112	4
27	continuous 4,000 Hz		105	6
28	alternating 800/970 Hz in 2 Hz stroke (250 ms-250 ms)		118	14
29	alternating 990/650 Hz in 2 Hz stroke (250 ms-250 ms)		117	14
30	alternating 510/610 Hz in 2 Hz stroke (250 ms-250 ms)		116	14
31	rising 300-1,200 Hz in 1 Hz stroke		118	14
32	continuous Bell		117	3
33	continuous Bell: 3x500 ms. Pulse, 1.5 sec. Silence, then repeat	Bell / US Temporal	117	14
34	alternating 1,000/2,000 Hz in 1 Hz stroke (500 ms-500 ms)	Singapore	115	4
35	pulse 420 Hz (0,625 sec.)	Australian alarm signal	118	14
36	500-1,200 Hz rising in 3,75 sec., then 0,25 sec. OFF	Australian alarm signal (Evacuation)	117	14
37	rising 1,400-1,600 Hz in 1 sec., falling in 0.5 sec.	NF C 48-265	116	14
38	500-1,200 Hz rising and falling 3 sec.	Siren	117	14
39	pulse 720 Hz: 0.7 sec. ON, 0.3 sec. OFF	German industrial alarm	118	14
40	rising 422-775 Hz in 0.85 sec., 1 sec. silence, then repeat	NFPA Whoop	118	14
41	continuous 470 Hz	Horn (USA)	114	3
42	continuous 370 Hz	Air Horn (USA)	113	3



Alarm Bell

Your benefits

A signalling technology classic: The robust WERMA Alarm Bell for signalling break-time or machine activation warnings.

- Many application possibilities
- Robust housing prevents damage when used in public areas or in harsh industrial environments

Typical applications

As a bell or alarm

- Goods receiving areas
- Entry/exit applications
- Counter service call point, etc.

Installation options

- Wall mounting

Features

- High IP66 protection rating for outdoor use



914 Alarm Bell



① TECHNICAL SPECIFICATIONS/ORDER SPECIFICATIONS:

Dimensions (Ø x Depth):	167 mm x 76 mm		
Housing:	Steel bell, epoxy powder coated		
Connection:	Screw terminal max. 1.5 mm ²		
Cable entry:	Cable gland M16 x 1.5 mm Cable diameter 5-10 mm		
Voltage:	24 V DC	110 V AC (50/60 Hz)	230 V AC
Current consumption:	300 mA	90 mA	55 mA
Order No.:	914 052 55	914 052 67	914 052 68 (50 Hz)

↔ TECHNICAL DIAGRAM:

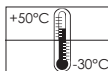
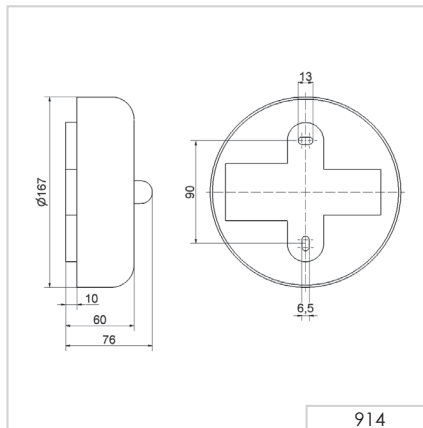

at DC - 98 dB(A)
at AC - 100 dB(A)



Optische & Akustische
Kombinationen
von
Ultraschall



Optical-audible combinations



Overview Optical and Audible Combinations

Double the safety with optical-audible signals

Large systems are often managed by only a few people, especially in automated production facilities and large machine shops. This results in optical signals not always being in the machine operator's immediate field of vision. In such cases, an audible signal may also be used. The use of both optical and audible alarms will help to counter an audible alarm not always being heard above an ambient noise level.

Overview Optical and Audible Combinations							
Product type		Installation	Free-standing	Free-standing	Free-standing	Free-standing	Free-standing
Mounting	Product range	Installation Combinations	EvoSIGNAL Mini	EvoSIGNAL Midi	Combinations	Design Combinations	Heavy Duty Combinations
Dimensions (Ø x Height)*		50 x 22 mm	62 x 85 mm	85 x 130 mm	146 x 171 mm 134 x 235 mm	-	
Dimensions (L x H x W)		-	-	-	134 x 407 x 144 mm	109 x 112,5 x 152 mm	136 x 138 x 119 mm 165 x 169 x 132 mm 168 x 211 x 155 mm
Voltage	12 V		●	●			●
	24 V	●	●	●	●	●	●
	60 V						●
	115 V	●	●	●	●	●	●
	230 V	●	●	●	●	●	●
Protection rating		IP65	IP66	IP66	IP65	IP65	IP66
Page		Page 200	Page 211	Page 214	Page 215	Page 221	Page 225

* Technical diagrams can be found on the product page



Variety of signals

WERMA supplies a large number of audible signals which can also be enhanced with the addition of optical light signals.

AUDIBLE SIGNALS: Sirens and Multi-Tone Sounder, Buzzer and Horns

OPTICAL SIGNALS: (LED) Permanent Light, Flashing Light, LED Double Flash Light, LED EVS Signal, LED Permanent/Flash/EVS Light

Size comparison



Series	EvoSIGNAL Mini	EvoSIGNAL Midi	Heavy Duty 441
Ø	62 mm	85 mm	-
Height	85 mm	130 mm	-
L x H x W	-	-	165 x 167 x 132 mm



Installation Combination Beacon with Buzzer

Your benefits

Optical audible Installation Combinations give excellent all-round visibility of the signal and are an industry standard for easy installation in control panels.

- Easy to install
- Tamper-proof when installed
- Minimal protrusion from panel for installations where space is limited
- Acknowledgement function promotes faster response time and fault repair (450 series)

Typical applications

Fault signalling

- in control panels

Installation options

- Installation mounting

Features

- High IP65 protection rating for outdoor applications
- Standard M22 for control panel installation
- Proven piezo technology for extended life duration
- Easy to connect using a plug-in connection (150)
- LED permanent light with continuous tone that can be additionally activated (150)



Size comparison Installation /
EvoSIGNAL Mini and Midi



150 LED Permanent Light / Buzzer Combination



LED Permanent light with continuous tone that can be additionally activated



① TECHNICAL SPECIFICATIONS/ORDER SPECIFICATIONS:

Dimensions (Ø x Height):	50 mm x 22 mm (Protrusion from panel)		
Housing:	PC/ABS-Blend		
Lens:	PC, transparent		
Connection:	Connector plug with screw terminal max. 1.5 mm ²		
Tone type:	Continuous		
Tone frequency:	c. 2.8 kHz		
Duty cycle:	100 %		
Life duration:	Up to 50,000 hrs		
Fixing:	Installation mounting for Ø 22.5 mm (M22 x 1.5 mm) with anti-twist device		
Nut and seal included in assembly.			
Voltage:	24 V DC	115 V AC	230 V AC
Current consumption:	< 50 mA	< 20 mA	< 20 mA
red	150 100 55	150 100 67	150 100 68
yellow	150 300 55	150 300 67	150 300 68

↔ TECHNICAL DIAGRAM:

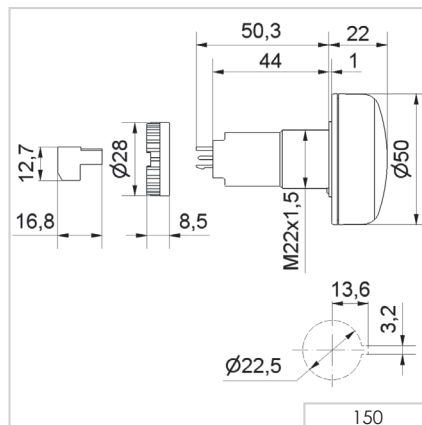

450 LED Permanent Light/Buzzer Combination with acknowledgement function



LED Permanent light with continuous tone that can be additionally activated



① TECHNICAL SPECIFICATIONS/ORDER SPECIFICATIONS:

Dimensions (Ø x Height):	50 mm x 22 mm (Protrusion from panel)	
Housing:	PC/ABS-Blend	
Lens:	PC, transparent	
Connection:	Screw terminal 1.5 mm ²	
Signal input:	24 V DC	
Acknowledgement output:	Semiconductor-Relay	U _{max} = 30 V I _{max} = 100 mA R _{ON max} = 25 Ohm
Tone type:	Continuous	
Tone frequency:	c. 2.8 kHz	
Duty cycle:	100 %	
Life duration:	Up to 50,000 hrs	
Fixing:	Installation mounting for Ø 22.5 mm (M22 x 1.5 mm)	
Nut and seal included in assembly.		
Voltage:	24 V DC	
Current consumption:	80 mA	
red	450 100 55	
yellow	450 300 55	

! ADDITIONAL INFORMATION:

1

The occurrence of a malfunction or an error is indicated by means of an optical-audible signal.

2

The audible signal can be turned off in seconds by lightly pressing the front of the product.

3

The acknowledgement signal is sent to the control unit via an electronic switch and the malfunction is now only indicated by the optical signal.

← TECHNICAL DIAGRAM:

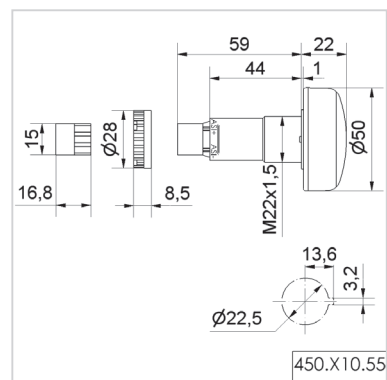
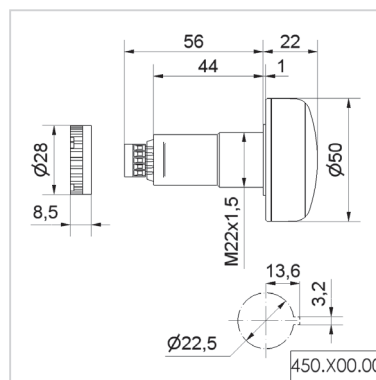

The audible signal can be turned off in seconds by lightly pressing the front of the product



450.X10.55



241 LED Installation Beacon (MC35) with UL



① TECHNICAL SPECIFICATIONS/ORDER SPECIFICATIONS

Dimensions (Ø x Height)	35 mm x 64 mm (Protrusion from panel)		
Housing	PC, black		
Lens	PC, transparent		
Fixing	Installation mounting M22		
Connection	M12 5 PIN		
Colour options	Red, yellow, green, white, blue, violet, turquoise (Multicolour) Red, yellow, green (Tricolour)		
Light effects	Permanent light		
Tone types and frequency	Continuous tone, 3400 Hz		
Life duration light	Up to 50,000 hrs		
Life duration buzzer	Up to 5,000 hrs		
Version with UL	Voltage	Current consumption	Plug M12
Tricolour (RGY)	24 V DC	32 mA	241 440 55
Multicolour (RGB)	10-30 V DC	70 mA	241 340 50

MC35 IO-Link

Connection	M12 4 PIN
Colour options	Multicolour LED, configurable colours > 1 million colours
Light effects	Permanent, blinking, flashing and pulse light
Tone types and frequency	10 tones (Permanent, Pulse, Sweep, Alternating)
Voltage	18-30 V DC
Current consumption	30 mA
Order no.	241 510 01

↔ TECHNICAL DIAGRAM

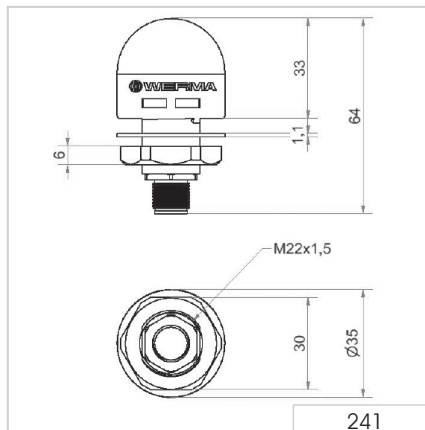



240 LED Installation Beacon (Multicolour/MC55) with or without UL

① TECHNICAL SPECIFICATIONS/ORDER SPECIFICATIONS

Dimensions (Ø x Height)	55 mm x 46 mm (Protrusion from panel)			
Housing	PC/ABS-Blend, black PC, black (version with UL)			
Lens	PC, transparent			
Fixing	Installation mounting M30			
Colour options	Red, yellow, green, white, blue, violet, turquoise (Multicolour) Red, yellow, green (Tricolour)			
Light effects	Permanent light, permanent and blinking light (1Hz) (240 130 50)			
Tone types and frequency	Pulse tone, 3400 Hz			
Life duration LED	Up to 50,000 hrs			
Life duration buzzer	Up to 5,000 hrs			
Without UL	Voltage	Current consumption	Plug M12	Cable
Tricolour (RGY)	24 V DC	45 mA	240 240 55	240 230 55
Multicolour (RGB)	10-30 V DC	80 mA	240 140 50	240 130 50
Version with UL	Voltage	Current consumption	Plug M12	
Tricolour (RGY)	24 V DC	65 mA	240 440 55	-
Multicolour (RGB)	10-30 V DC	105 mA	240 340 50	-

240 LED Installation Beacon (Multicolour/MC55 Smart) with UL

① TECHNICAL SPECIFICATIONS/ORDER SPECIFICATIONS

Dimensions (Ø x Height)	55 mm x 46 mm (Protrusion from panel)
Housing	PC black
Lens	PC, transparent
Fixing	Installation mounting M30
Connection	M12 5 PIN
Colour options	Multicolour LED, configurable colours > 1 million colours
Light effects	Permanent, blinking, flashing and pulse light
Tone types and frequency	10 tones (Permanent, Pulse, Sweep, Alternating)
Life duration LED	Up to 50,000 hrs
Life duration buzzer	Up to 5,000 hrs
Output current	max. 200 mA
Output	Pulse feedback, 24 V switching
Voltage	24 V DC
Current consumption	max. 135 mA
Order no.	240 520 01

↔ TECHNICAL DIAGRAM:

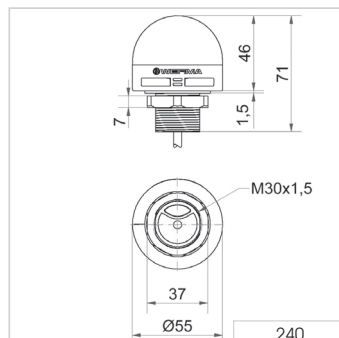

240.440.55
240.340.50
240.520.01

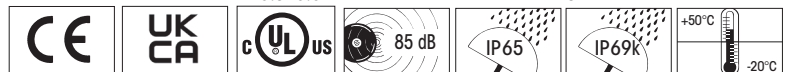

Configuration software for the Smart version

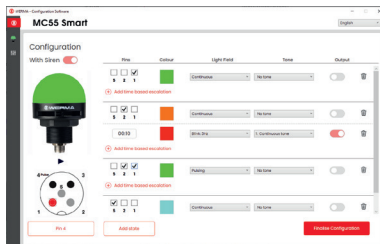

240 LED Installation Beacon (Multicolour/MC55 IO-Link)



① TECHNICAL SPECIFICATIONS / ORDER SPECIFICATIONS

Dimensions (Ø x Height)	55 mm x 46 mm (Protrusion from panel)
Housing	PC black
Lens	PC, transparent
Fixing	Installation mounting M30
Connection	M12 4 PIN
Colour options	Red, yellow, green, white, blue, violet, turquoise (Multicolour)
Light effects	Permanent, blinking, flashing and pulse light
Tone types and frequency	10 tones (Permanent, Pulse, Sweep, Alternating)
Life duration LED	Up to 50,000 hrs
Life duration buzzer	Up to 5,000 hrs
Voltage	18-30 V DC
Current consumption	60 mA
Order no.	240 510 01

↔ TECHNICAL DIAGRAM:

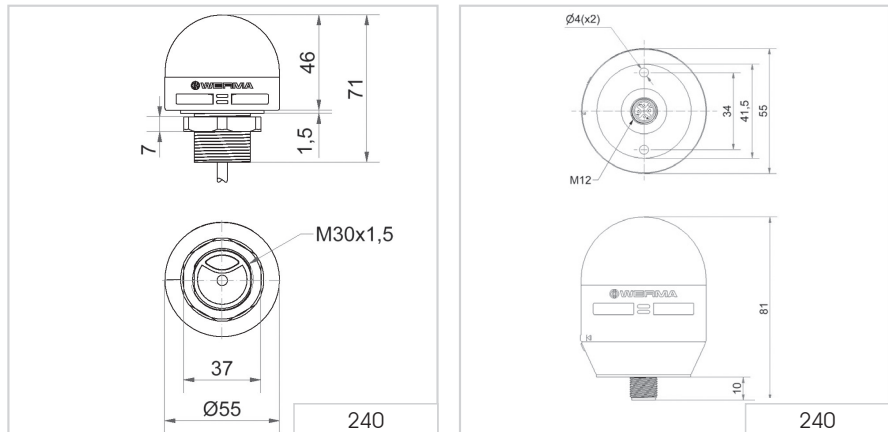



240 LED Installation Beacon (Multicolour/MC55 Touch)

TECHNICAL SPECIFICATIONS/ORDER SPECIFICATIONS

Dimensions (Ø x Height)	55 mm x 44 mm (Protrusion from panel)			
Housing	PC, black			
Lens	PC, transparent			
Fixing	Installation mounting M22			
Connection	M12 5 PIN			
Colour options	Red, yellow, green (Tricolour)			
Light effects	Permanent light			
Tone types and frequency	Continuous tone, 3480 Hz			
Output current	max. 200 mA			
Output	Puls Feedback			
Life duration light	Up to 50,000 hrs			
Life duration buzzer	Up to 5,000 hrs			
	Voltage	Current consumption	NPN	PNP
Tricolour (RGY)	24 V DC	max. 200 mA	240 270 55	240 290 55

240 LED Installation Beacon (Multicolour/MC55 Touch Smart)

TECHNICAL SPECIFICATIONS/ORDER SPECIFICATIONS

Dimensions (Ø x Height)	55 mm x 44 mm (Protrusion from panel)		
Housing	PC, black		
Lens	PC, transparent		
Fixing	Installation mounting M22		
Connection	M12 5 PIN		
Colour options	Red, yellow, green, white, blue, violet, turquoise (Multicolour)		
Light effects	Permanent, Blinking, Flashing and Pulse light		
Tone types and frequency	10 tones (Continuous, Pulse, Sweep, Alternating)		
Output current	max. 200 mA		
Output	Pulse Feedback, commutation 24 V		
Life duration light	Up to 50,000 hrs		
Life duration buzzer	Up to 5,000 hrs		
	Voltage	Current consumption	M12 connector
Multicolour (RGY)	24 V DC	max. 200 mA	240 170 55

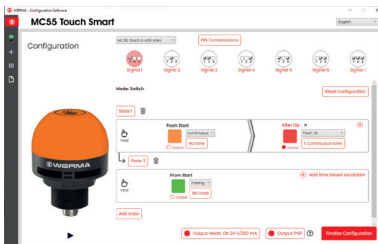

Configuration software for the Smart version

TECHNICAL DIAGRAM

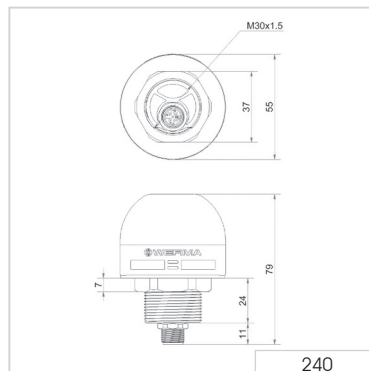

240 LED Installation Beacon (Multicolour/MC55 Touch IO-Link)



① TECHNICAL SPECIFICATIONS/ORDER SPECIFICATIONS

Dimensions (Ø x Height)	55 mm x 44 mm (Protrusion from panel)
Housing	PC black
Lens	PC, transparent
Fixing	Installation mounting M22
Connection	M12 4 PIN
Colour options	Multicolour LED, configurable colours > 1 million colours
Light effects	Permanent, Blinking, Flashing and Pulse light
Tone types and frequency	10 tones (Continuous, Pulse, Sweep, Alternating)
Output	Feedback via IO-Link process data
Life duration light	Up to 50,000 hrs
Life duration buzzer	Up to 5,000 hrs
Voltage	18-30 V DC
Current consumption	60 mA
Order no.	240 510 03

↔ TECHNICAL DIAGRAM

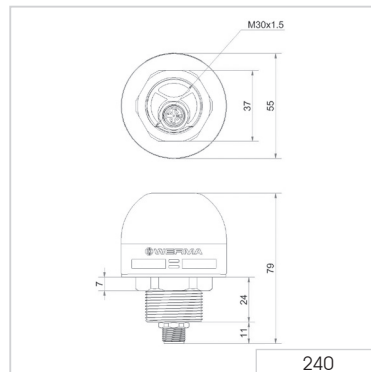



240 LED Beacon Multicolour MC55 High Tube and base mounting

TECHNICAL SPECIFICATIONS/ORDER SPECIFICATIONS

Dimensions (Ø x Height)	55 mm x 111 mm
Housing	PC black
Lens	PC, transparent
Fixing	Installation mounting M30
Connection	M12 5 PIN (IO-Link: M12 4 PIN)
Life duration light	Up to 50,000 hrs
Life duration buzzer	Up to 5,000 hrs

MC55 High

Colour options	Red, yellow, green, white, blue, violet, turquoise (Multicolour) Red, yellow, green (Tricolour)		
Light effects	Permanent light		
Tone types and frequency	Pulse tone, 3400 Hz		
	Voltage	Current consumption	M12
Tricolour (RGY)	24 V DC	60 mA	240 600 04
Multicolour (RGB)	10-30 V DC	max. 135 mA	240 600 02

MC55 High Smart

Colour options	Multicolour LED, configurable colours > 1 million colours
Light effects	Permanent, blinking, flashing and pulse light
Tone types and frequency	10 tones (Permanent, Pulse, Sweep, Alternating)
Output current	max. 200 mA
Output	Pulse Feedback, commutation 24 V
Voltage	24 V DC
Current consumption	max. 135 mA
Order no.	240 620 01

MC55 High IO-Link

Colour options	Multicolour LED, configurable colours > 1 million colours
Light effects	Permanent, blinking, flashing and pulse light
Tone types and frequency	10 tones (Permanent, Pulse, Sweep, Alternating)
Voltage	18-30 V DC
Current consumption	60 mA
Order no.	240 610 01



TECHNICAL DIAGRAM

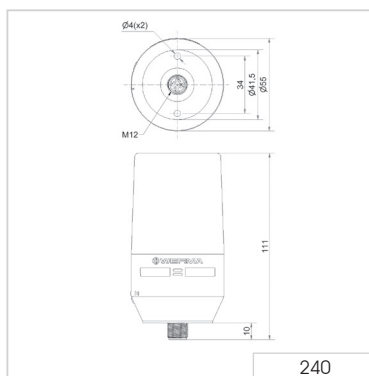

240 LED Installation Beacon Multicolour MC55 High



① TECHNICAL SPECIFICATIONS/ORDER SPECIFICATIONS

Dimensions (Ø x Height)	55 mm x 77 mm (Protrusion from panel)		
Housing	PC black		
Lens	PC, transparent		
Fixing	Installation mounting M30		
Connection	M12 5 PIN (IO-Link: M12 4 PIN)		
Life duration light	Up to 50,000 hrs		
Life duration buzzer	Up to 5,000 hrs		

MC55 High

Colour options	Red, yellow, green, white, blue, violet, turquoise (Multicolour) Red, yellow, green (Tricolour)		
Light effects	Permanent light		
Tone types and frequency	Pulse tone, 3400 Hz		
	Voltage	Current consumption	M12
Tricolour (RGY)	24 V DC	60 mA	240 600 12

MC55 High IO-Link

Colour options	Multicolour LED, configurable colours > 1 million colours		
Light effects	Permanent, blinking, flashing and pulse light		
Tone types and frequency	10 tones (Permanent, Pulse, Sweep, Alternating)		
Voltage	18-30 V DC		
Current consumption	60 mA		
Order no.	240 610 03		

↔ TECHNICAL DIAGRAM

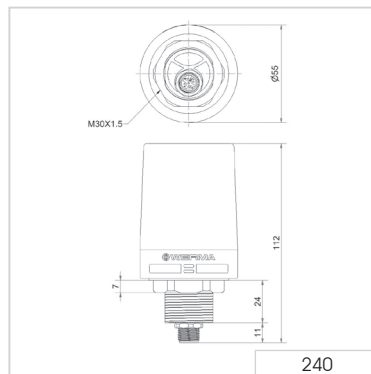

Evo*SIGNAL* - Combinations

Your benefits

The type of optical signals used depends on the application and environment. With Evo*SIGNAL*, finding the right signal device has never been so easy: Almost all areas of application are optimally covered by only two sizes (combinations) with specific mounting adapters. The new modular, simple and clear standard solution. Evo*SIGNAL* is one of a kind.

- Simple and easy to use: Number of different articles reduced to 20% whilst retaining a full range
- Twin functions: Twin*LIGHT* and Twin*FLASH* unite two light pattern functions in one element. They can be remote-controlled via connection terminals and also used as escalation levels
- Poka Yoke: Simple and intuitive installation - incorrect installation is impossible
- Mini and Midi also available as Tri*COLOUR* variants
- Maxi Twin*FLASH* can be used as an attention-grabbing alternative to xenon strobes and rotating mirror beacons

Typical applications

Signal faults and statuses on machines and equipment, in building services engineering and in door and gate applications. All products are ideal for demanding indoor and outdoor applications.

- Mini – in installation sites with limited space
- Midi – signalling over medium distances (10–30 m)

Installation options

- Base mounting
- M22/PG 29 single-hole mounting
- Tube mounting
- Bracket mounting

Features

- Push-in connection terminals: Simple and permanently secure connection
- Fully compatible: Easy replacement of previous products
- Best-in-class equipment: Powerful, extremely robust (IP66), tamper-proof



Mini

Midi



Evo*SIGNAL* Mini - Combinations

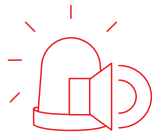
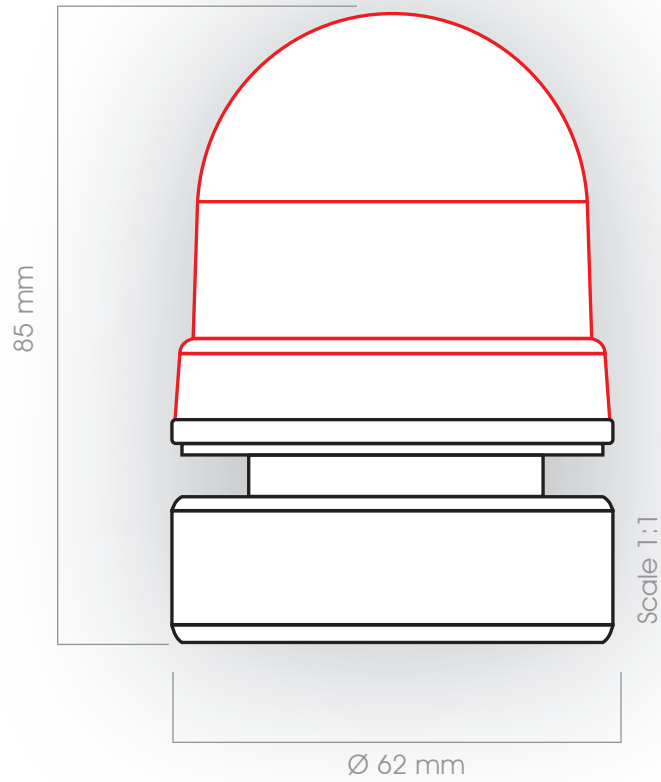

30
Twin*LIGHT*, Twin*FLASH*



6
Mounting adapter





Quick-Finder EvoSIGNAL Mini - Combinations



12 V AC/DC		24 V AC/DC		115-230 V AC	
TwinLIGHT	TwinFLASH	TwinLIGHT	TwinFLASH	TwinLIGHT	TwinFLASH
Order No.	Order No.	Order No.	Order No.	Order No.	Order No.
460 110 74	460 120 74	460 110 75	460 120 75	460 110 60	460 120 60
460 210 74	460 220 74	460 210 75	460 220 75	460 210 60	460 220 60
460 310 74	460 320 74	460 310 75	460 320 75	460 310 60	460 320 60
460 410 74	460 420 74	460 410 75	460 420 75	460 410 60	460 420 60
460 510 74	460 520 74	460 510 75	460 520 75	460 510 60	460 520 60

+ Mounting adapter (compulsory!)

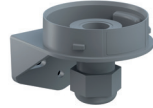
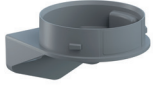
Base mounting	Installation mounting M22	Installation mounting PG 29	Tube mounting	Bracket mounting with cable gland	Bracket mounting
					
Order no. 260 700 01	Order no. 260 700 03	Order no. 260 700 04	Order no. 260 700 05	Order no. 260 700 06	Order no. 260 700 07

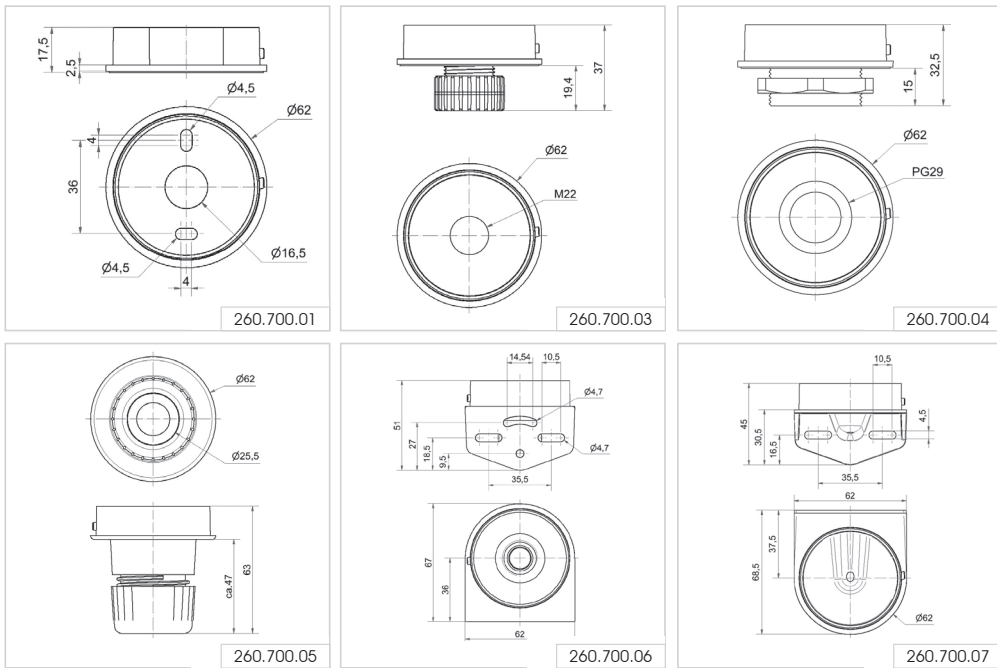

EvoSIGNAL Mini - Combinations



Installation mounting M 22



Tube mounting



Installation mounting PG 29

① TECHNICAL SPECIFICATIONS/ORDER SPECIFICATIONS:

Dimensions (Ø x Height):	62 x 85 mm
Housing:	PC/ABS
Lens:	PC, transparent
Connection:	Push-In terminal max. 1.5 mm ²
Cable entry:	Cable diameter 8-12 mm
Tone type:	Continuous or Pulse tone
Fixing:	Base/Tube/Wall/ Installation mounting
Flashing/Blinking frequency:	1Hz

TwinLIGHT			
Voltage:	12 V AC/DC	24 V AC/DC	115-230 V AC
Current consumption:	≤ 120 mA	≤ 115 mA	≤ 75 mA
red	460 110 74	460 110 75	460 110 60
green	460 210 74	460 210 75	460 210 60
yellow	460 310 74	460 310 75	460 310 60
white	460 410 74	460 410 75	460 410 60
blue	460 510 74	460 510 75	460 510 60

TwinFLASH			
Voltage:	12 V AC/DC	24 V AC/DC	115-230 V AC
Current consumption:	≤ 100 mA	≤ 115 mA	≤ 75 mA
red	460 120 74	460 120 75	460 120 60
green	460 220 74	460 220 75	460 220 60
yellow	460 320 74	460 320 75	460 320 60
white	460 420 74	460 420 75	460 420 60
blue	460 520 74	460 520 75	460 520 60

✂ ACCESSORIES:

Base mounting	260 700 01
Installation mounting M22	260 700 03
Installation mounting PG 29	260 700 04
Tube mounting	260 700 05
Bracket mounting with cable gland	260 700 06
Bracket mounting	260 700 07

↔ TECHNICAL DIAGRAM:

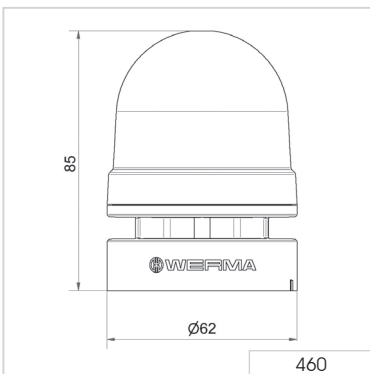

EvoSIGNAL Midi - Combinations

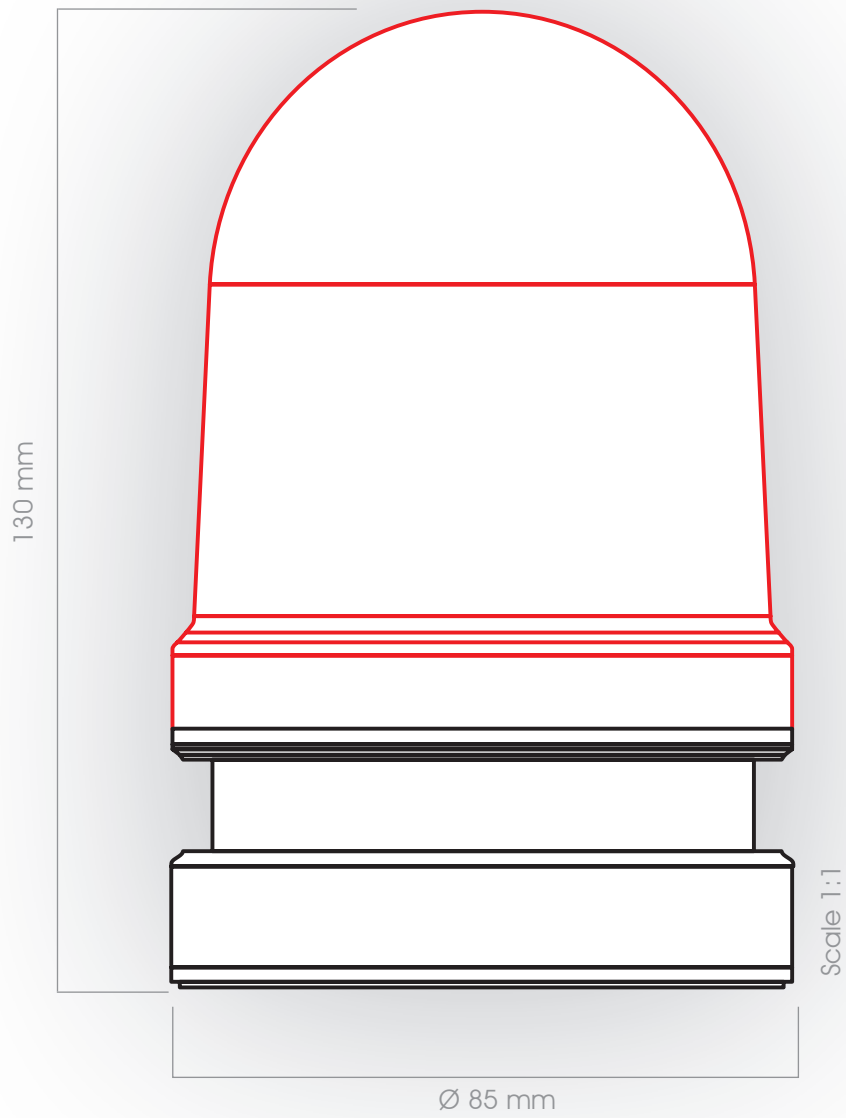

20
TwinLIGHT, TwinFLASH



6
Mounting adapter

EvoSIGNAL Midi - Combinations



Horn



Bracket mounting with cable gland



Tube mounting

① TECHNICAL SPECIFICATIONS/ORDER SPECIFICATIONS:

Dimensions (Ø x Height):	85 mm x 130 mm	
Housing:	PC/ABS	
Lens:	PC, transparent	
Fixing:	Base/Tube/Wall mounting	
Cable entry:	Cable diameter 8-12 mm	
Connection:	Push-In terminal max. 1.5 mm ²	
Tone type:	Multi-tone, 10 tones	
Flashing/Blinking frequency:	1 Hz	

TwinLIGHT

Voltage:	12/24 V AC/DC	115-230 V AC
Current consumption:	≤ 345 mA	≤ 170 mA
red	461 110 70	461 110 60
green	461 210 70	461 210 60
yellow	461 310 70	461 310 60
white	461 410 70	461 410 60
blue	461 510 70	461 510 60

TwinFLASH

Voltage:	12/24 V AC/DC	115-230 V AC
Current consumption:	≤ 110 mA	≤ 215 mA
red	461 120 70	461 120 60
green	461 220 70	461 220 60
yellow	461 320 70	461 320 60
white	461 420 70	461 420 60
blue	461 520 70	461 520 60

✖ ACCESSORIES:

Base mounting	261 700 01
Base mounting with cable gland	261 700 02
Tube mounting	261 700 05
Bracket mounting with cable gland	261 700 06
Bracket mounting	261 700 07
Horn	261 700 03

↔ TECHNICAL DIAGRAM:

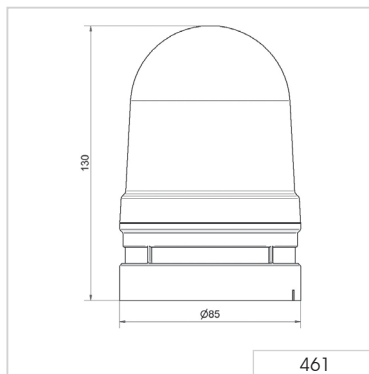

Combination LED Beacon with Multi-Tone Sounder/Horn

Your benefits

The WERMA LED Beacon with a siren or horn provides safety and security by delivering reliable fault alarms over medium distances. The IP65 protection rating is suitable for outdoor applications.

- Multiple light configurations for different purposes and distances (some with partial external triggering)
- Simple installation
- Tamper-proof when installed
- Multiple visual and audible escalation levels possible
- Clear all-round visibility thanks to the OmniVIEW lens; no blind spots
- Multi-tone siren with up to 32 tones available for maximum flexibility

Typical applications

Fault signalling

- In areas with high ambient noise levels
- On machinery and equipment
- In building service systems (e.g. gas alarm)
- In the event of e.g. overload on mobile cranes and similar

Installation options

- Base mounting
- Wall mounting
- Tube mounting

Features

- Long life and energy-saving LEDs



430/432 LED Permanent Light/Multi-Tone Sounder Combination



LED Permanent Light in combination with Multi-Tone Sounder



Quick and simple wall mounting without additional accessories thanks to integrated mounting bracket (432)



Mounting holes integrated into the product rim allow easy mounting without having to remove the lens (430)

① TECHNICAL SPECIFICATIONS/ORDER SPECIFICATIONS:

	Base mounting (430)	Wall mounting (432)
Dimensions (Ø x Height):	146 mm x 171 mm	134 mm x 235 mm
Housing:	PC/ABS-Blend, black	PC/ABS-Blend, grey
Lens:	PC, transparent	
Connection:	Screw terminal 0.5-1.5 mm ²	
Cable entry:	Cable diameter max. 13 mm	
Tone type and frequency:	32 tones adjustable, see table on page 218	
Life duration:	Up to 50,000 hrs (LED), up to 5,000 hrs (Multi-tone Sounder)	
Installation position:	Sound outlet facing downwards	
Fixing:	Base mounting (430), Wall mounting (432) Tube mounting (accessory, only for 430)	
Voltage:	24 V AC/DC	115-230 V AC*
Current consumption MTS:	190 mA	55 mA
Current consumption LED:	350 mA 230 mA (red)	100 mA 80 mA (red)
Base mounting		
red	430 100 75	430 100 60
yellow	430 300 75	430 300 60
Wall mounting		
red	432 100 75	432 100 60
yellow	432 300 75	432 300 60

*Current consumption at 115 V

✂ ACCESSORIES:

Adaptor for tube mounting, plastic, for tube Ø 25 mm	975 430 01
--	-------------------

↔ TECHNICAL DIAGRAMS:

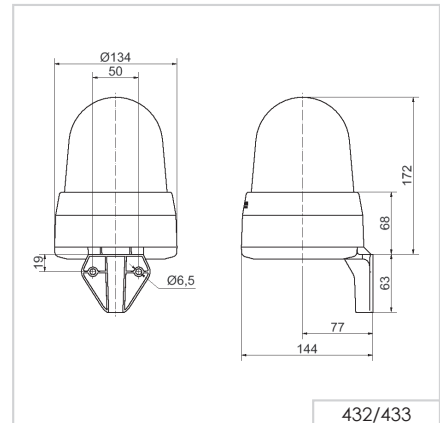
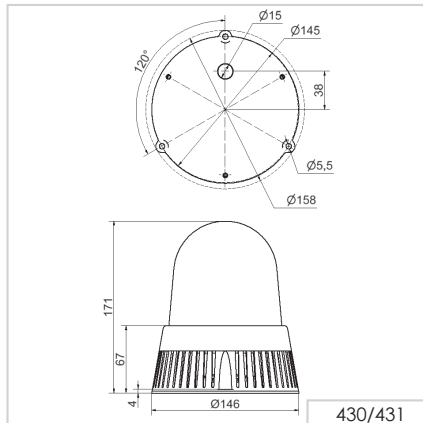

431/433 LED Permanent / Flashing / EVS / Multi-Tone Sounder Combination



Multi-functional LED beacon:
3 light effects can be externally triggered



The adaptor enables mounting on a tube (431)

① TECHNICAL SPECIFICATIONS/ORDER SPECIFICATIONS:

	Base mounting (431)	Wall mounting (433)
Dimensions (Ø x Height):	146 mm x 171 mm	134 mm x 235 mm
Housing:	PCABS-Blend, black	PC/ABS-Blend, grey
Lens:	PC, transparent	
Connection:	Screw terminal 0,5-1,5 mm ²	
Cable entry:	Cable diameter max. 13 mm	
Tone type and frequency:	32 tones adjustable, see table on page 218	
Installation position:	Sound outlet facing downwards	
Life duration:	Up to 50,000 hrs (LED), up to 5,000 hrs (Multi-tone Sounder)	
Fixing:	Base mounting (431), Wall mounting (433) Tube mounting (accessory, only for 431)	
Voltage:	24 V AC/DC	115-230 V AC*
Current consumption MTS:	190 mA	55 mA
Current consumption LED:	350 mA 230 mA (red)	100 mA 80 mA (red)
Base mounting		
red	431 100 75	431 100 60
yellow	431 300 75	431 300 60
Wall mounting		
red	433 100 75	433 100 60
yellow	433 300 75	433 300 60

*Current consumption at 115 V

✂ ACCESSORIES:

Adaptor for tube mounting, plastic, for tube Ø 25 mm	975 430 01
--	-------------------

← TECHNICAL DIAGRAMS:

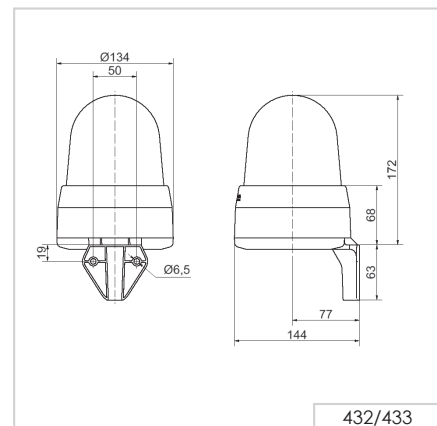
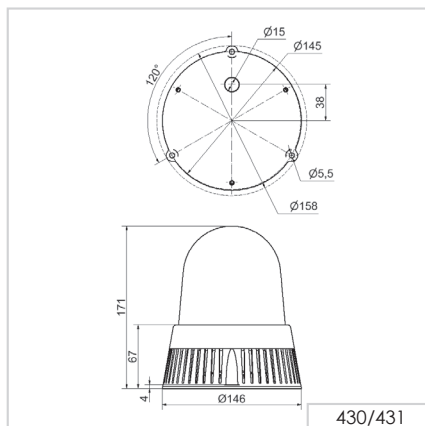

43 x Tone table for Multi-Tone Sounder

The Multi-Tone Sounder Combinations 43x offer a large choice of internationally recognised signal tones for the widest range of applications. The tone types and frequencies can be found in the table below:

🎵 TONE TYPES AND FREQUENCIES:						
Tone 1	Tone type	Frequency (Hz)	Description	Use	Tone 2	Sound output (dba)
1	continuous	200		BS 5839-1:2002	440 Hz cont.	97
2	rising	800 & 970	7 Hz		14	102
3	rising	800 & 970	1 Hz		14	103
4	continuous	2850			14	104
5	rising	2400 - 2850	7 Hz		4	109
6	rising	2400 - 2850	1 Hz		4	110
7	rising	500 - 1200	3 s, then 0.5 s OFF (then repeat)		14	106
8	falling	1200 - 500	1 Hz	DIN 33404-3	14	104
9	alternating	2400 & 2850	2 Hz		4	111
10	pulse	970	0.5 Hz (1 s On/1 s Off)	BS 5839 Part 1 1988	14	101
11	alternating	800 & 970	1 Hz	BS 5839 Part 1 1988	14	105
12	pulse	2850	0.5 Hz		4	104
13	pulse	970		0,25 s On/1 s Off	14	98
14	continuous	970		BS 5839-1:2002 PFEER - Toxic gas	10	102
15	alternating	554 & 440		France NFS	14	101
16	pulse	660	150 ms On/150 ms Off	Swedish	16	96
17	pulse	660	1.8 s On/1.8 s Off	Swedish	17	98
18	pulse	660	6.5 s On/13 s Off	Swedish	18	98
19	continuous	660		Swedish	19	98
20	alternating	554 & 440	0.5 Hz		20	102
21	pulse	660	1 Hz	Swedish	21	97
22	pulse	2850	150 ms On/100 ms Off	GB	14	104
23	rising	800 - 970	50 Hz (low)	BS 5839 Part 1 1988	14	102
24	rising	2400 - 2850	50 Hz (high)		4	109
25	pulse	970	3 x 500 ms ON/500 ms OFF / 1.5 s silence, then repeat (low)	ISO 8201 US Temporal	26	101
26	pulse	2850	3 x 500 ms ON/500 ms OFF / 1.5 s silence, then repeat (high)	ISO 8201 US Temporal	25	104
27	continuous	4000			27	92
28	rising	2000 - 2850	7 Hz		2000 Hz cont.	111
29	alternating	988 & 645	2 Hz		988 Hz cont.	102
30	alternating	510 & 610	2 Hz		510 Hz cont.	102
31	alternating	800 & 970	2 Hz	5839-1:2002	800 Hz cont.	105
32	alternating	800 & 1200	1 Hz		800 Hz cont.	105



434 LED Permanent Light / Horn Combination



Award winning design Winner of the iF product design award 2012



Quick and simple wall mounting without additional accessories thanks to integrated mounting bracket

① TECHNICAL SPECIFICATIONS/ORDER SPECIFICATIONS:

Dimensions (L x H x W):	134 mm x 407 mm x 144 mm	
Housing:	PC/ABS-Blend, grey	
Lens:	PC, transparent	
Connection:	Screw terminal 0.5-1.5 mm ²	
Cable entry:	Cable diameter max. 13 mm	
Tone frequency:	c. 110 Hz	
Life duration:	Up to 50,000 hrs (LED), up to 5,000 hrs (Horn)	
Fixing:	Wall mounting, integrated mounting bracket	
Installation position:	Sound outlet facing downwards	
Voltage:	24 V AC/DC	115-230 V AC*
Current consumption MTS:	55 mA	30 mA
Current consumption LED:	350 mA 230 mA (red)	100 mA 80 mA (red)
red	434 100 75	434 100 60
yellow	434 300 75	434 300 60

*Current consumption at 115 V

← TECHNICAL DIAGRAMS:

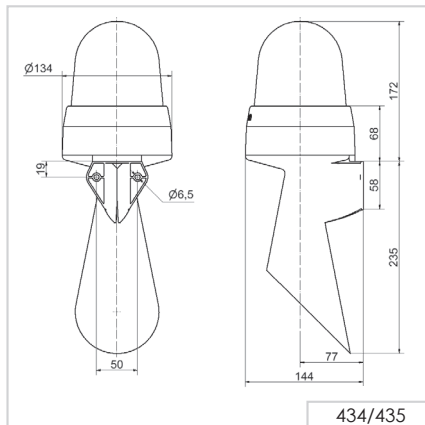

435 LED Permanent/Flashing/EVS/Horn Combination



Multi-functional LED beacon:
3 light effects can be triggered
externally



The "EVS" light effect ensures a
maximum attention-grabbing
effect

① TECHNICAL SPECIFICATIONS/ORDER SPECIFICATIONS:

Dimensions (L x H x W):	134 mm x 407 mm x 144 mm	
Housing:	PC/ABS-Blend, grey	
Lens:	PC, transparent	
Connection:	Screw terminal 0.5-1.5 mm ²	
Cable entry:	Cable diameter max. 13 mm	
Tone frequency:	c. 110 Hz	
Life duration:	Up to 50,000 hrs (LED), up to 5,000 hrs (Horn)	
Fixing:	Wall mounting, integrated mounting bracket	
Installation position:	Sound outlet facing downwards	
Voltage:	24 V AC/DC	115-230 V AC*
Current consumption MTS:	55 mA	30 mA
Current consumption LED:	350 mA 220 mA (red)	100 mA 80 mA (red)
red	435 100 75	435 100 60
yellow	435 300 75	435 300 60

*Current consumption at 115 V

← TECHNICAL DIAGRAMS:

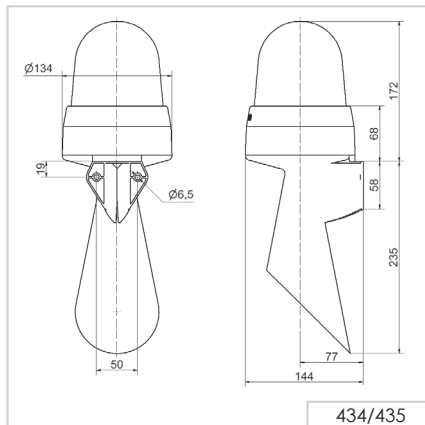

Design Combination LED Multi-Tone Sirens

Your benefits

The Design Combination LED Multi-Tone Sirens provide safety and security in environments with heightened aesthetic design requirements. The innovative housing design makes for simple mounting in many diverse applications.

- Ideal signalling effect over great distances
- Multiple visual and audible escalation levels possible
- Many application options with up to 32 tones available
- Up to 3 tones controlled remotely for the escalation of signals
- Includes standardised tones (including those used in fire alarms)

Typical applications

Fault signalling

- In building service systems
- On machinery and equipment

Installation options

- Wall mounting
- Base mounting
- Ceiling mounting

Features

- Multi-voltage versions allow multiple applications with a single device
- Long life and energy-saving LEDs, either as a flashing light or EVS



Size comparison Design / Heavy Duty



444 LED Double Flash/Multi-Tone Sounder Combination



Base mounting



Wall mounting

① TECHNICAL SPECIFICATIONS/ORDER SPECIFICATIONS:

Dimensions (L x H x W):	109 mm x 112 mm x 150 mm		
Housing:	PC/ABS-Blend		
Lens:	PC, transparent		
Connection:	24 V: Screw terminal 0.5-1.5 mm ² 115/230 V: CAGE CLAMP®		
Cable entry:	Membrane for cable diameter max. 13 mm		
Life duration:	Up to 50,000 hrs (LED Double Flash)		
Flash frequency:	c. 1 Hz		
Fixing:	Wall, base and ceiling mounting		
Voltage:	24 V AC/DC	115 V AC	230 V AC
Current consumption Optical:	60 mA	30 mA	30 mA
Current consumption Audible:	200 mA	55 mA	30 mA
red	444 100 75	444 100 67	444 100 68
yellow	444 300 75	444 300 67	444 300 68

✂ ACCESSORIES:

Cable gland M20 x 1.5 mm (for cable strain relief)	975 444 01
Protection rating IP 65 is guaranteed even without cable gland	

🎵 TONE TYPES AND FREQUENCIES:

Selectable via DIP switch, see tone table on page 226, 3 tones can be externally triggered

↩ TECHNICAL DIAGRAMS:

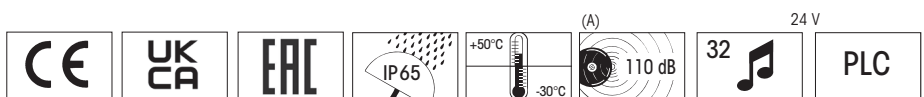
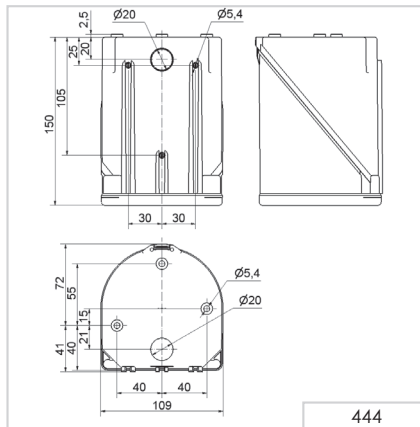

444 LED EVS / Multi-Tone Sounder Combination



Base mounting



The „EVS“ light effect ensures a maximum attention-grabbing effect

① TECHNICAL SPECIFICATIONS/ORDER SPECIFICATIONS:

Dimensions (L x H x W):	109 mm x 112 mm x 150 mm		
Housing:	PC/ABS-Blend		
Lens:	PC, transparent		
Connection:	24 V: Screw terminal 0.5-1.5 mm ² 115/230 V: CAGE CLAMP®		
Cable entry:	Membrane for cable diameter max. 13 mm		
Fixing:	Wall, base and ceiling mounting		
Life duration:	Up to 50,000 hrs (LED EVS)		
Voltage:	24 V AC/DC	115 V AC	230 V AC
Current consumption Optical:	60 mA	30 mA	30 mA
Current consumption Audible:	220 mA	55 mA	30 mA
red	444 110 75	444 110 67	444 110 68
yellow	444 310 75	444 310 67	444 310 68

✂ ACCESSORIES:

Cable gland M20 x 1.5 mm (for cable strain relief)	975 444 01
Protection rating IP 65 is guaranteed even without cable gland	

🎵 TONE TYPES AND FREQUENCIES:

Selectable via DIP switch, see tone table on page 224, 3 tones can be externally triggered

↔ TECHNICAL DIAGRAMS:

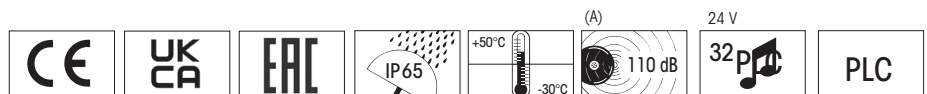
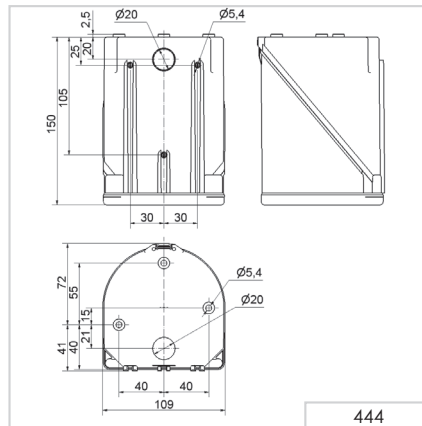

444 Combination

The 444 Combinations offer a large choice of internationally recognised signal tones for the widest spectrum of applications. 3 tones can be triggered externally.

STONE TYPES AND FREQUENCIES:

Tone 1	Tone type	Frequency (Hz)	Description	Use	Tone 2	Sound output (dbA)
1	continuous	200		BS 5839-1:2002	440 Hz cont.	97
2	rising	800 & 970	7 Hz		14	102
3	rising	800 & 970	1 Hz		14	103
4	continuous	2850			14	104
5	rising	2400 - 2850	7 Hz		4	109
6	rising	2400 - 2850	1 Hz		4	110
7	rising	500 - 1200	3 s, then 0.5 s OFF (then repeat)		14	106
8	falling	1200 - 500	1 Hz	DIN 33404-3	14	104
9	alternating	2400 & 2850	2 Hz		4	111
10	pulse	970	0.5 Hz (1 s On/1 s Off)	BS 5839 Part 1 1988	14	101
11	alternating	800 & 970	1 Hz	BS 5839 Part 1 1988	14	105
12	pulse	2850	0.5 Hz		4	104
13	pulse	970		0,25 s On/1 s Off	14	98
14	continuous	970		BS 5839-1:2002 PFEER - Toxic gas	10	102
15	alternating	554 & 440		France NFS	14	101
16	pulse	660	150 ms On/150 ms Off	Swedish	16	96
17	pulse	660	1.8 s On/1.8 s Off	Swedish	17	98
18	pulse	660	6.5 s On/13 s Off	Swedish	18	98
19	continuous	660		Swedish	19	98
20	alternating	554 & 440	0.5 Hz		20	102
21	pulse	660	1 Hz	Swedish	21	97
22	pulse	2850	150 ms On/100 ms Off	GB	14	104
23	rising	800 - 970	50 Hz (low)	BS 5839 Part 1 1988	14	102
24	rising	2400 - 2850	50 Hz (high)		4	109
25	pulse	970	3 x 500 ms ON/500 ms OFF / 1.5 s silence, then repeat (low)	ISO 8201 US Temporal	26	101
26	pulse	2850	3 x 500 ms ON/500 ms OFF / 1.5 s silence, then repeat (high)	ISO 8201 US Temporal	25	104
27	continuous	4000			27	92
28	rising	2000 - 2850	7 Hz		2000 Hz cont.	111
29	alternating	988 & 645	2 Hz		988 Hz cont.	102
30	alternating	510 & 610	2 Hz		510 Hz cont.	102
31	alternating	800 & 970	2 Hz	5839-1:2002	800 cont.	105
32	alternating	800 & 1200	1 Hz		800 cont.	105



Heavy Duty Combination – Multi-Tone Siren with Xenon Flash

Your benefits

The WERMA Heavy Duty Combination - Multi-Tone Siren with Xenon Flash features a very robust housing. The combination device provides safety and security through reliable, loud signalling in particularly harsh environments. Up to 120 dB for use in extremely noisy environments and signalling over long distances.

- Multiple visual and audible escalation levels possible
- Includes standardised tones (including those used in fire alarms)
- Up to 42 tones for signalling various statuses

Typical applications

Signalling of faults or alarms

- Outdoors in extreme conditions
- In larger industrial plants
- As an evacuation alarm

Installation options

- Wall mounting

Features

- High protection rating IP66
- Multi-voltage versions available



Size comparison Heavy Duty / Design



439 Xenon Flash / Multi-Tone Sounder Combination (105 dB)



① TECHNICAL SPECIFICATIONS/ORDER SPECIFICATIONS:

Dimensions (L x H x W):	136 mm x 138 mm x 119 mm	
Housing:	ABS	
Connection:	Screw terminal 0.28-2.5 mm ²	
Cable entry:	Cable gland M20 x 1.5 mm (not included in assembly)	
Flash frequency:	1 Hz	
Flash energy	1.6 Ws	
Tone type and frequency:	Selectable via DIP switch, 2 tones can be externally triggered	
Voltage:	9-60 V DC	110-230 V AC
Current consumption:	230 mA (24 V)	30 mA (230 V)
Housing/Flash		
red / red	439 010 55	439 010 68
red / yellow	439 030 55	439 030 68
grey / red	439 110 55	439 110 68
grey / yellow	439 130 55	439 130 68

✂ ACCESSORIES:

Cable gland M20 x 1.5 mm (for cable strain relief)	975 444 01
Protection rating IP 65 is guaranteed even without cable gland	

♪ TONE TYPES AND FREQUENCIES:

For further details see www.werma.com.

↔ TECHNICAL DIAGRAMS:

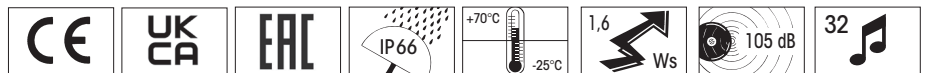
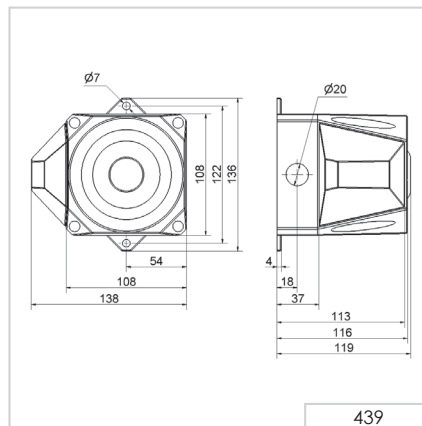

441 Xenon Flash / Multi-Tone Sounder Combination (110 dB)



① TECHNICAL SPECIFICATIONS/ORDER SPECIFICATIONS:

Dimensions (L x H x W):	165 mm x 169 mm x 132 mm	
Housing:	PC/ABS-Blend	
Connection:	Screw terminal 0.28-2.5 mm ²	
Cable entry:	Cable gland M20 x 1.5 mm (not included in assembly)	
Flash frequency:	1 Hz	
Flash energy	2.5 Ws	
Tone type and frequency:	Selectable via DIP switch, 2 tones can be externally triggered	
Voltage:	9-60 V DC	230 V AC
Current consumption:	230 mA	35 mA
Housing/Flash		
red / red	441 010 55	441 010 68
red / yellow	441 030 55	441 030 68
grey / red	441 110 55	441 110 68
grey / yellow	441 130 55	441 130 68

✂ ACCESSORIES:

Cable gland M20 x 1.5 mm (for cable strain relief)	975 444 01
Protection rating IP 65 is guaranteed even without cable gland	

🎵 TONE TYPES AND FREQUENCIES:

For further details see www.werma.com.

↔ TECHNICAL DIAGRAMS:

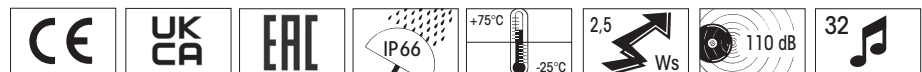
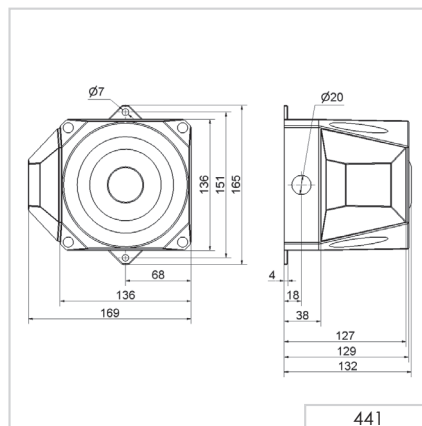

442 Xenon Flash / Multi-Tone Sounder Combination (120 dB)



① TECHNICAL SPECIFICATIONS/ORDER SPECIFICATIONS:

Dimensions (L x H x W):	168 mm x 211 mm x 155 mm	
Housing:	PC/ABS-Blend	
Connection:	Screw terminal 0.28-2.5 mm ²	
Cable entry:	Cable gland M20 x 1.5 mm (not included in assembly)	
Tone type and frequency:	Selectable via DIP switch, 3 tones externally triggered see table on page 231	
Voltage:	18-30 V DC	115/230 V AC
Current cons. Multi Tone Sounder:	450 mA	130/65 mA
Current consumption Flash:	127-389 mA (dependent on voltage and flash frequency)	- /15 mA (dependent on voltage and flash frequency)
Flash frequency	0.75 Hz/1 Hz	1.25 Hz/2 Hz
Flash energy	3.5 Ws	2 Ws
Housing/Flash		1 Hz (Flash can only be operated with 230 V)
red / red	442 010 55	442 010 68
red / yellow	442 030 55	442 030 68
grey / red	442 110 55	442 110 68
grey / yellow	442 130 55	442 130 68

✂ ACCESSORIES:

Cable gland M20 x 1.5 mm (for cable strain relief) Protection rating IP 65 is guaranteed even without cable gland	975 444 01
--	-------------------

↔ TECHNICAL DIAGRAMS:

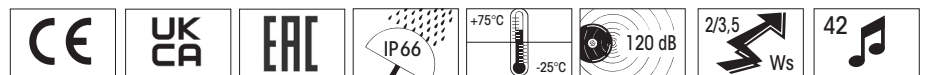
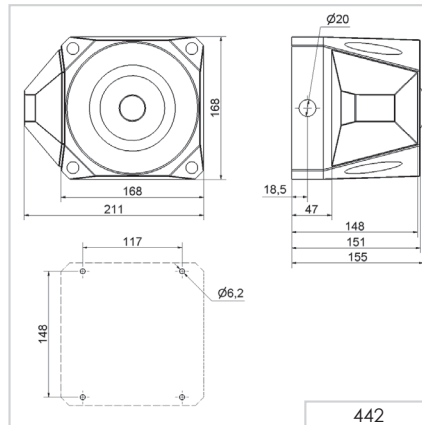

442 Combination

The Flash/Multi-Tone Sounder Combination 442 offers a large choice of internationally recognised signal tones for the widest spectrum of applications. 3 tones can be triggered externally. The first two tones can be freely chosen. The third tone is paired with the second tone.

♪ TONE TYPES AND FREQUENCIES:

Tone 1+2 No	Tone type	Use	Output (dbA)	Tone 3
1	alternating 800/970 Hz in 2 Hz stroke (250 ms-250 ms)		120	14
2	rising 800/970 Hz in 7 Hz stroke (7/s)		120	14
3	rising 800/970 Hz in 1 Hz stroke (1/s)		120	14
4	continuous 2,850 Hz		111	9
5	rising 2,400-2,850 Hz in 7 Hz stroke		109	4
6	rising 2,400-2,850 Hz in 1 Hz stroke		110	4
7	500-1,200 Hz rising in 3 sec., 0.5 sec. OFF	Slow Whoop Holland	119	14
8	falling 1,200-500 Hz in 1 Hz stroke	DIN/PFEER (PAPA), DIN 33404-3, VDS tested	119	14
9	alternating 2,400/2,850 Hz in 2 Hz stroke (250 ms-250 ms)		113	4
10	pulse 970 Hz in 0.5 Hz stroke (1 sec. ON / 1 sec. OFF)	PFEER Alarm	117	14
11	alternating 800/970 Hz in 1 Hz stroke (500 ms-500 ms)		118	14
12	pulse 2,850 Hz in 0.5 Hz stroke (1 sec. ON / 1 sec. OFF)		112	4
13	970 Hz pulse: 0.25 sec. ON / 1 sec. OFF		117	14
14	continuous 970 Hz	PFEER - Toxic gas	118	8
15	554 Hz/100 ms alternating 440 Hz/400 ms	French alarm signal AFNOR NFS 32S 32-001	115	14
16	660 Hz pulse: 150 ms ON, 150 ms. OFF	Swedish alarm signal	114	14
17	660 Hz pulse: 1.8 sec. ON, 1.8 sec. OFF	Swedish alarm signal	115	14
18	660 Hz pulse: 6.5 sec. ON, 13 sec. OFF	Swedish alarm signal	115	14
19	continuous 660 Hz	Swedish alarm signal	116	1
20	alternating 554/440 Hz in 0.5 Hz stroke (1 sec. ON / 1 sec. OFF)	Swedish alarm signal	115	19
21	pulse 660 Hz in 1 Hz stroke (500 ms-500 ms)	Swedish alarm signal	115	4
22	pulse 2,850 Hz in 4 Hz stroke (150 ms ON / 100 ms OFF)	Swedish alarm signal	110	4
23	rising 800-970 Hz in 50 Hz stroke	Swedish alarm signal	117	14
24	rising 2,400-2,850 Hz in 50 Hz stroke	Swedish alarm signal	110	4
25	970 Hz pulse.: 3 x 500 ms. ON, 500 ms OFF, break 1.5 sec.	ISO 8201 / US Temporal	118	14
26	2,850 Hz pulse.: 3 x 500 ms. ON, 500 ms OFF, break 1.5 sec.	ISO 8201 / US Temporal	112	4
27	continuous 4,000 Hz		105	6
28	alternating 800/970 Hz in 2 Hz stroke (250 ms-250 ms)		118	14
29	alternating 990/650 Hz in 2 Hz stroke (250 ms-250 ms)		117	14
30	alternating 510/610 Hz in 2 Hz stroke (250 ms-250 ms)		116	14
31	rising 300-1,200 Hz in 1 Hz stroke		118	14
32	continuous Bell		117	3
33	continuous Bell: 3x500 ms. Pulse, 1.5 sec. Silence, then repeat	Bell / US Temporal	117	14
34	alternating 1,000/2,000 Hz in 1 Hz stroke (500 ms-500 ms)	Singapore	115	4
35	pulse 420 Hz (0,625 sec.)	Australian alarm signal	118	14
36	500-1,200 Hz rising in 3.75 sec., then 0.25 sec. OFF	Australian alarm signal (Evacuation)	117	14
37	rising 1,400-1,600 Hz in 1 sec., falling in 0.5 sec.	NF C 48-265	116	14
38	500-1,200 Hz rising and falling in 3 sec.	Siren	117	14
39	pulse 720 Hz: 0.7 sec. ON, 0.3 sec. OFF	German industrial alarm	118	14
40	rising 422-775 Hz in 0.85 sec., 1 sec. silence, then repeat	NFPA Whoop	118	14
41	continuous 470 Hz	Horn (USA)	114	3
42	continuous 370 Hz	Air Horn (USA)	113	3



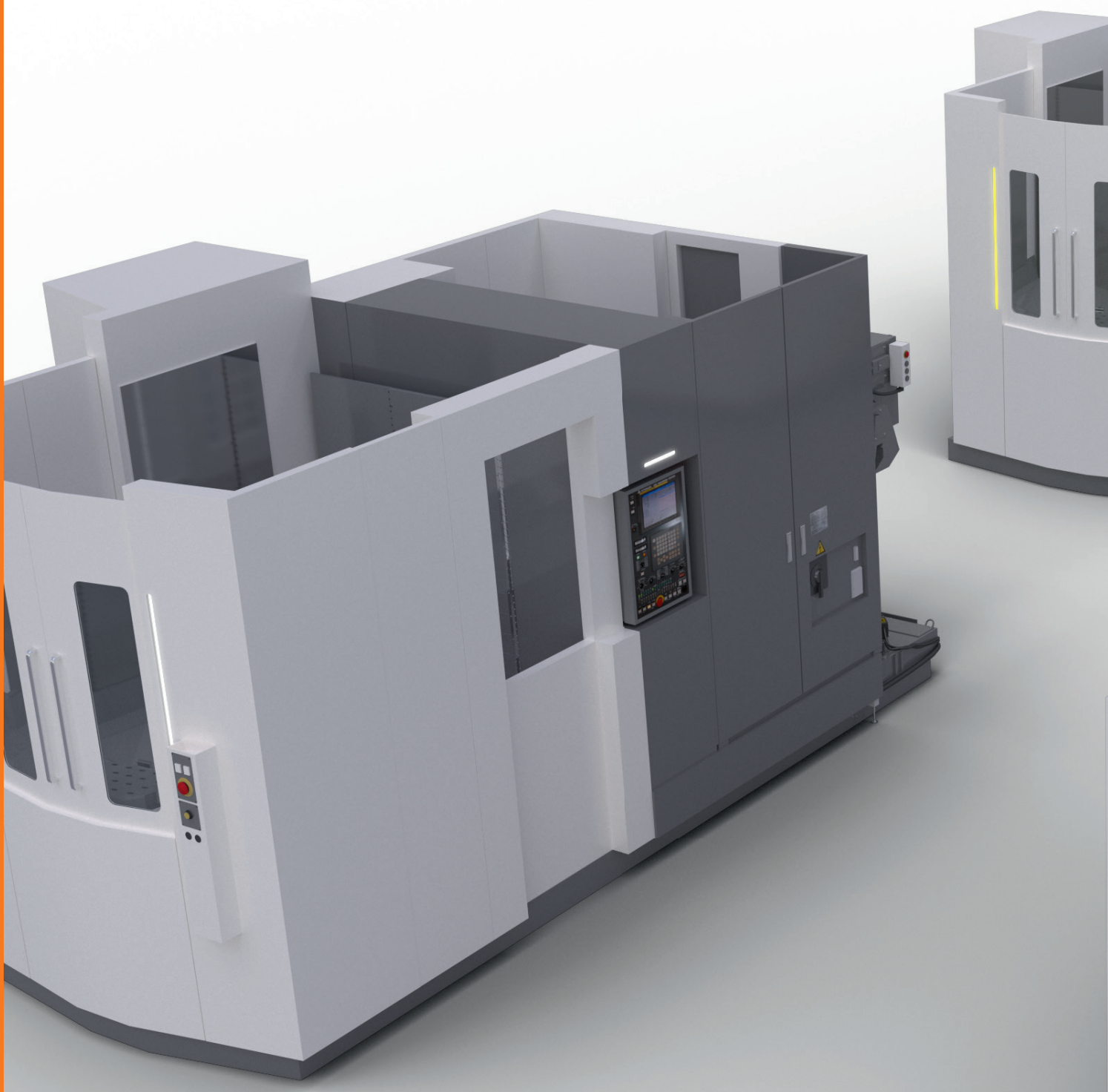



Integrated signalling

LineLIGHT Fusion - integrated signalling

Your benefits

With LineLIGHT Fusion, WERMA offers a fully integrable signalling solution that integrates seamlessly into the main product and impresses with standardised modules from the LineLIGHT Fusion series as a high-quality, functional design element. The display of machine statuses is integrated as a function in the machine design, which transfers all the benefits of signalling in terms of safety, efficiency and productivity into the design of the machine.

The fully integrated solution also supports the hygienic requirements of the production environment. The precise integration into the machine surface minimises dirty edges, avoids openings and offers a high level of protection against the ingress of dust and liquids.

The homogeneous, full-surface illumination of the LineLIGHT Fusion modules ensures

- optimum visibility
- Reliably signals hazards or critical machine states

Optional:

- Light modules with additional acoustic warning
- Can be configured in 50 mm increments between 100 mm and 1500 mm
- Different light contours and images

Typical application

For machine and system manufacturers who want to implement a consistent machine design with an integrated signalling solution, for signalling machine statuses, on

- machines
- automation systems
- assembly systems
- Transport and conveyor belts
- All other industrial products that have a sheet metal housing

Installation options

- Screw mounting using a clip
- Adhesive mounting using industrial adhesive tape

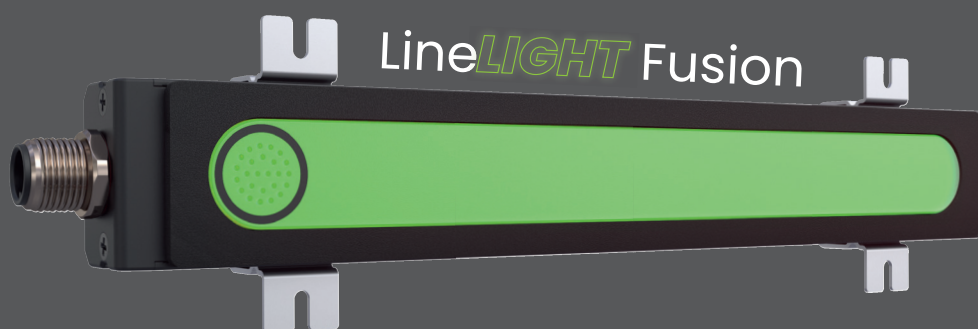

LineLIGHT Fusion



LineLIGHT Fusion in the dimensions 100, 200 and 500 mm with or without acoustics. Further sizes available on request.



Mounting clips

TECHNICAL SPECIFICATIONS/ORDER SPECIFICATIONS

	100 mm	200 mm	500 mm
Dimension (L x H x W)	145 x 33 x 23 mm	245 x 33 x 23 mm	545 x 33 x 23 mm
Housing	Aluminium, black		
Lens	PC, transparent		
Fixing	Installation mounting		
Connection	M12 5-pin		
Colour options	Red, yellow, green, white, blue, violet, turquoise (Multicolour)		
Tone type	Pulse tone		
Voltage	24 V DC		
With acoustic			
Clips	300 100 02	300 100 06	300 100 10
Tape	300 100 04	300 100 08	300 100 12
Current consumption	110 mA	165 mA	325 mA
Without acoustic			
Clips	300 100 01	300 100 05	300 100 09
Tape	300 100 03	300 100 07	300 100 11
Current consumption	100 mA	155 mA	315 mA

Individual sizes in 50 mm steps from 100 to 1500 mm possible on request.

TECHNICAL DIAGRAM

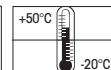
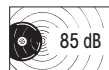
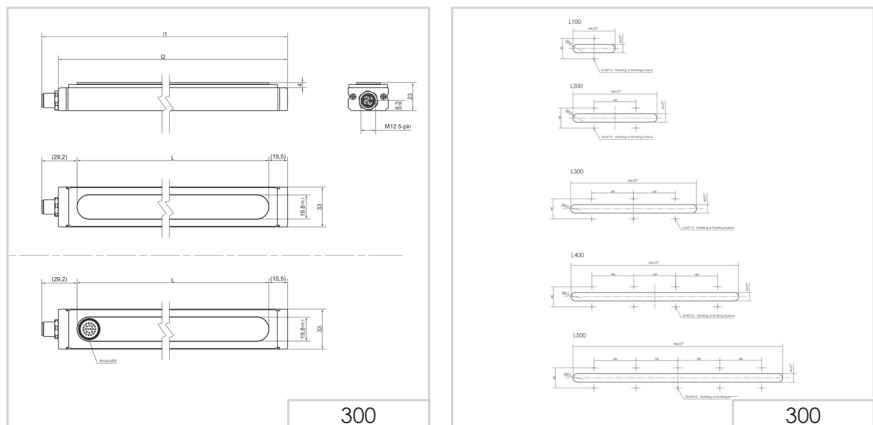

LineLIGHT Fusion segments

Your benefits

LineLIGHT Fusion is also available as a segment version. This allows the light pattern to be divided into several sections. With the 200 mm version, either the entire length can be illuminated in a single colour or it can be divided into two 100 mm segments with different colours. From a length of 300 mm, up to three segments are possible: continuous illumination over 300 mm, two segments of 150 mm each or three segments of 100 mm each, each of which can also be displayed in different colours.

The homogeneous, full-surface illumination of the LineLIGHT Fusion modules ensures

- optimum visibility
- Reliably signals hazards or critical machine states

Optional:

- Light modules with additional acoustic warning
- Different light contours and images

Typical application

For machine and system manufacturers who want to implement a consistent machine design with an integrated signalling solution, for signalling machine statuses, on

- machines
- automation systems
- assembly systems
- Transport and conveyor belts
- All other industrial products that have a sheet metal housing

Installation options

- Screw mounting using a clip



LineLIGHT Fusion segments

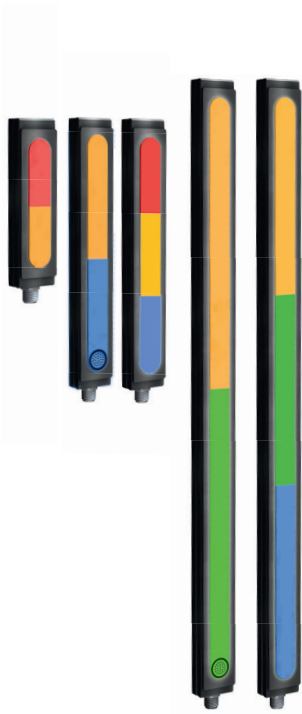

LineLIGHT Fusion in sizes 200, 300 and 900 mm with and without acoustics.



Mounting clips

① TECHNICAL SPECIFICATIONS/ORDER SPECIFICATIONS

	200 mm	300 mm	600 mm	900 mm
Dimension (L x H x W):	245 x 33 x 23 mm	345 x 33 x 23 mm	645 x 33 x 23 mm	945 x 33 x 23 mm
Housing:	Aluminium, black			
Lens:	PC, transparent			
Fixing:	Installation mounting			
Connection:	M12 5-pin			
Colour options:	Red, yellow, green, white, blue (Multicolour) Colour selection depends on variant			
Tone type:	Pulse tone			
Voltage:	24 V DC			
Number of segments	1-2	1-3	1-3	1-3
With acoustic				
Clip	300 100 66	300 100 68	300 100 70	300 100 72
Current consumption	170 mA	220 mA	380 mA	545 mA
Without acoustic				
Clip	300 100 65	300 100 67	300 100 69	300 100 71
Current consumption	160 mA	210 mA	375 mA	535 mA

Sizes 1200 and 1500 mm available on request.

↔ TECHNICAL DIAGRAM

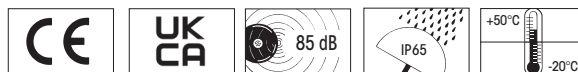
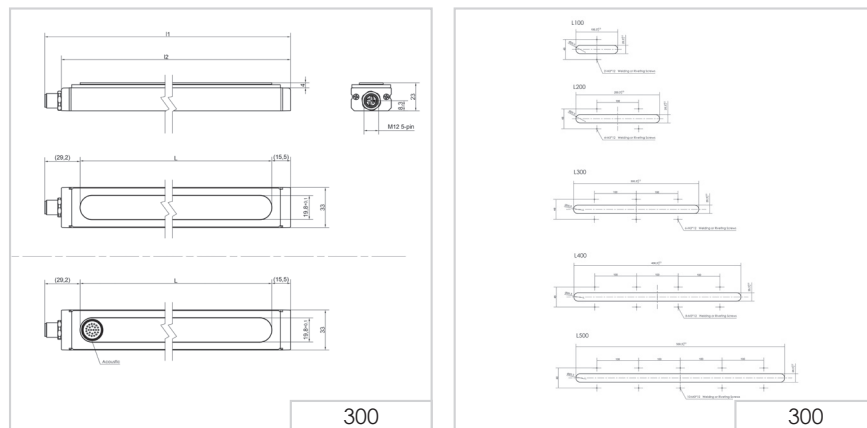

Product number index



Product no.	Page
107	159
109	160
110	161
111	162
114	163
118	164
119	164
123	174
126	175
127	replaced by 160
128	replaced by 160
129	188
133	replaced by 161
134	replaced by 161
139	190
140	181
141	191
142	192
144	183
150	201
153	143
154	186
160	169
161	172
190	146
200	replaced by 260
201	replaced by 260
202	replaced by 260
203	replaced by 260
204	replaced by 260
205	replaced by 260
206	replaced by 260
207	replaced by 260
208	replaced by 260
209	replaced by 260
210	replaced by 260
211	replaced by 260
212	replaced by 260
213	replaced by 260
214	replaced by 260
215	replaced by 260
216	replaced by 260
219	replaced by 260
220	replaced by 260

Product no.	Page
221	replaced by 260
222	replaced by 260
223	replaced by 260
224	replaced by 260
225	replaced by 260
230	97
231	98
239	AS-Interface 100
240	without buzzer 102+107
240	with buzzer 204-209
241	without buzzer 101
241	with buzzer 203
260	109+115
261	118+130
262	121+130
280	replaced by 262
280	LED Obstruction Light 133
281	134
300	235+237
420	replaced by 460 + 461
421	replaced by 460 + 461
422	replaced by 460 + 461
423	replaced by 460 + 461
424	replaced by 460
425	replaced by 460
430	218
431	219
432	218
433	219
434	221
435	222
439	228
441	229
442	230
444	224
450	with acknowledgement 202
460	212
461	215
570	176
573	177
574	178
575	179
584	replaced by 161
585	replaced by 161

Product no.	Page
630	Terminal elements 31
631	IO Link KS 40 31
634	LED elements 29
635	Audible elements 30
639	28
640	Terminal elements KS 71 45
640	Terminal elements KS 72 37
641	41
643	41
644	LED elements 41+42
645	Audible elements KS 71 43+44
645	Audible elements KS 72 36
646	AS-Interface 47
647	LED elements 35
649	Pre-configured KS 71 40
649	Pre-configured KS 72 34
657	63
686	67
690	77
691	75
694	71
695	73
698	60
699	60
800	110
801	111
802	replaced by 260
806	124
816	USB multicolour 112
826	replaced by 261
827	replaced by 261
828	replaced by 261
829	replaced by 261
829	monitored 125
839	LED Permanent 136
839	LED Rotating 137
853	LED Permanent 139
853	LED Double flash 140
853	LED EVS 141
860	AndonLIGHT 48
860	AndonSMARTBOX 51
860	AndonCONTROL 52
860	AndonWIRELESS 53
861	KombiSIGN reflect EU 56



Systems





Systems for optimising production and logistics areas



Intelligent signalling technology from WERMA – Industry 4.0 simply realised

In addition to classic signalling devices, WERMA offers intelligent solutions that make Industry 4.0 tangible, experiential and immediately implementable. Our systems are ready-to-use plug-and-play solutions that work out-of-the-box – simply install and get started. Because at WERMA, signalling technology is taken to the next level!

With our call and signalling systems (AndonLIGHT, KombiSIGN Reflect and AndonWIRELESS), you can quickly and easily report faults at manual workstations or implement access controls on doors and gates – professionally and efficiently – without additional software.

Our WeASSIST platform enables the collection, visualisation and evaluation of all process data in real time. This gives you full transparency over your production, increases efficiency and secures your long-term competitiveness – whether in manual, shipping or automated production areas.

More information at werma.com



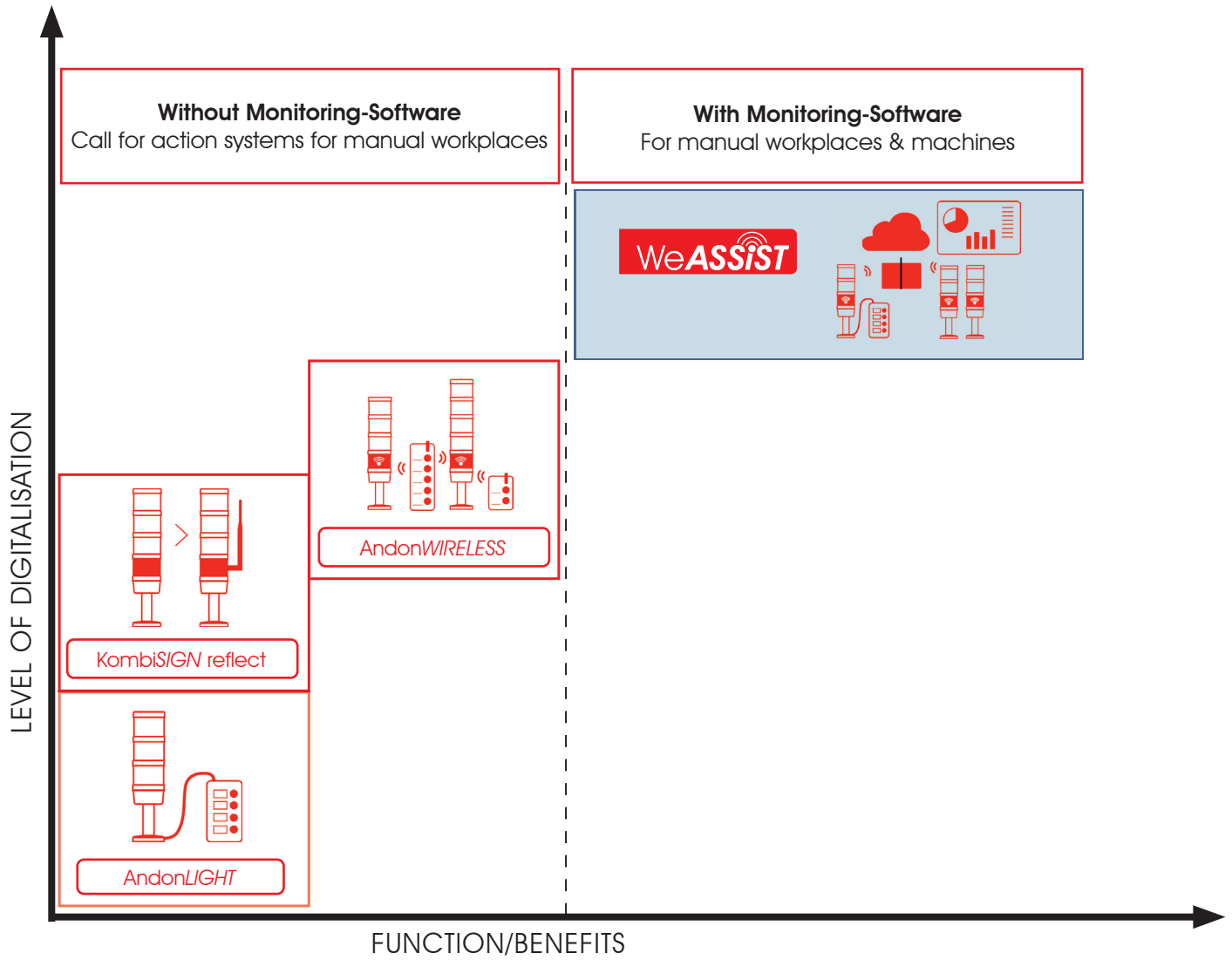

WERMA Signaltechnik GmbH + Co. KG

Erich-Marquardt-Str. 1
D-78604 Rietheim-Weilheim
Phone +49 7424 9557-0
Fax +49 7424 9557-44
www.werma.com
info@werma.com

WERMA Signaltechnik

Niederlassung Neuhausen am Rhf.
Rheingoldstrasse 50
8212 Neuhausen am Rheinfeld
Switzerland
Phone +41 52 674 0060
Fax +41 52 674 0066
www.werma.com
info@werma.ch

WERMA Italia S.r.l.

Via dell'Artigianato 42
29122 Piacenza
Italy
Phone +39 05 23 04 45 44
www.werma.com
info@werma.it

WERMA SARL

56, Rue Collière
69780 Mions
France
Phone +33 47222 3737
www.werma.com
info@werma.fr

WERMA BENELUX

Poortakkerstraat 41C
9051 Sint-Denijs-Westrem
Belgium
Phone +32 9 220 31 11
www.werma.com
info@wermbenelux.com

WERMA (UK) Ltd.

11 Regent Park
37 Booth Drive
Park Farm Industrial Estate
Wellingborough NN8 6GR
Great Britain
Phone +44 1536 486930
Fax +44 1536 514810
www.werma.com
uksales@werma.co.uk

WERMA USA Inc.

1266 Oakbrook Dr, Suite A
Norcross, GA 30093 USA
Phone +1 470 361 0600
www.werma.com
us-info@werma.com

WERMA (Shanghai) Co., Ltd.

Building 8, No. 85, Mingnan Road,
Songjiang, Shanghai, P.R. C
201613
China
Phone +86 21 5774-0022
Fax +86 21 5774-6601
www.werma.com.cn
info@werma.com.cn

